



## PolluStat

# Installation and operating instructions

The ultrasonic meter PolluStat is suitable for the measurement of energy consumption in heating or cooling plants filled with the energy carrier liquid water.

These installation and operating instructions specify the installation and the operation of PolluStat and its variants. It is an essential part of the delivered items and has to be handed over to the final user.

### Delivered items

- PolluStat (if applicable with already connected temperature sensors)
- 2 gaskets
- sealing material
- these installation and operating instructions

### Content

1. Important directions .....	2
2. Technical data .....	3
3. Required tools.....	3
4. Installation of sub-assemblies .....	3
4.1 Flow sensor.....	3
4.2 Installation of temperature sensors.....	4
4.3 Mounting of the integrator.....	5
4.4 Connection of temperature sensors.....	5
5. Display options .....	6
5.1 Main menu (L1).....	6
5.2 Archiv menu (L2).....	7
5.3 Information menu (L3).....	9
6. Functional test, sealing .....	10
7. Possible error situations.....	10
8. Standard interfaces and optional modules .....	10
8.1 Optical interface .....	10
8.2 M-Bus plug-in module acc. to EN 13757-3 .....	10
8.3 Mini-Bus plug-in module.....	10
8.4 Remote pulse Output / Input.....	11
8.5 Inserting the plug into the heat meter .....	11
8.6 Integrated data logger .....	11

## 1. Important directions



- The installation of PolluStat requires adequate professional knowledge and should be carried out by specially trained persons only.
- The technical data specified in chapter 2 must not be exceeded during operation.
- During the installation of PolluStat, the well or ball valve, particular care is to be taken that they are perfectly mounted, because otherwise there might be the **danger of being scalded** by leaking heating liquid. Therefore, first of all, the stop cocks are to be closed before removal.
- Depending on manufacturing conditions the brass connection threads might be sharp-edged. Therefore we recommend wearing protection gloves.
- The connection cable between flow sensor and calculator must not be cut, shortened or extended.
- Heating or cooling meters are measuring instruments and have to be handled with care. In order to protect them against damages and soiling they should only be taken from the package immediately before installation.
- The instrument must not be carried by the cable.
- For cleaning purposes use nothing else but a cloth moistened with water.
- Within the instrument there is a battery, which must not be opened by force, come into contact with water, be short-circuited or exposed to temperatures exceeding 80 °C.
- Empty batteries, no longer needed electronic instruments or components are hazardous waste and to be disposed of at suitable collecting points.
- If several meters are used in the same billing unit, equal instrument types should be chosen in the interest of the fairest possible consumption billing.

### 2. Technical data

Calculator	
Temperature measuring range h	$\Theta = 0 \dots 180 \text{ }^\circ\text{C}$
Temperature difference range	$\Delta\Theta = 3 \dots 150 \text{ K}$
Switch-off threshold	0,15 K
Measuring accuracy	Better than: $+ (0,5 + \Delta\Theta_{\min} / \Delta\Theta) \%$
Updating times and integration cycles resp.:	
Flow rate	1 sec
Temperatures, power	16 sec
Energy, volume	16 sec
Optical data interface	Physical acc. to EN 61107 Data record acc. to EN 13757-3
Suitable temperature sensors	Pt 500 Connection in two-wire technology
Connection cable between calculator and flow sensor	1,2 m
Power supply (using period of the meter may be defined by national laws)	Battery for 11 years
Electromagnetic environment condition	Class E 2
Mechanical environment condition	Class M 1
Protection class	IP 54
Ambient temperature	5 ... 55 °C
Storing temperature	-20 ... +65 °C
Relative air humidity	< 93 %
Size (H x W x D) in terms of wall mounting	115 x 90 x 45 mm
Flow sensor	
Temperature range	5 ... 130 °C for $q_p \leq 2,5 \text{ m}^3/\text{h}$ 10 ... 130 °C for $q_p \geq 3,5 \text{ m}^3/\text{h}$
Protection class	IP 65
Straight inlet and outlet pipes	Not required acc. to approval directives up to DN40.  For meter size DN 40 a straight pipe of 5 x DN in front of the flow sensor and 3 x DN after the flow sensor is mandatory.
Installation position	Any position, even head down

### 3. Required tools

- Fork wrench in suitable size for thread connections or flange screws resp.
- Screw driver slot 0,5x3 (terminal block)
- Side cutter for sealing wire

### 4. Installation of sub-assemblies

The text hereinafter includes following terms:

return pipe of heating plants: **colder line**  
supply pipe of heating plants: **warmer line**

#### 4.1 Flow sensor

Applicable standards: EN 1434-6

Standard installation of the flow sensor is in the heating return pipe i.e. the colder line. If the flow sensor is to be installed in the heating supply pipe i.e. the warmer line, the integrator PolluStat adjusted for flow sensors in the warmer line is to be used.

**An arrow on the body shows the flow direction.** The maximum operating pressure and the maximum operating temperature must not be exceeded.

It is absolutely advisable to install a dirt trap before the flow sensor or at another suitable point of the heating or chilling circuit as well as shut-off valves before and after the flow sensor (in order to avoid having to empty the pipeline if the meter is to be exchanged). During initial installation a spool piece is installed instead of the flow sensor and the pipe system is thoroughly flushed. Then close the shut-off valves, remove the spool piece, clean the sealing surfaces and install the flow sensor using new gaskets. Take care not to reduce the pipe diameter by bad positioning of the gaskets, particularly if flanged versions are installed.

In areas with thermal layering (e.g. after the junction of two pipes with different temperatures) a straight pipe of 10 x DN in front of the flow sensor is recommended.

#### Special direction for installation of meters of DN 40 ( $q_p$ 10):

For meter size DN 40 a straight pipe of 5 x DN in front of the flow sensor and 3 x DN after the flow sensor is mandatory.

## Examples of installation in heating systems:

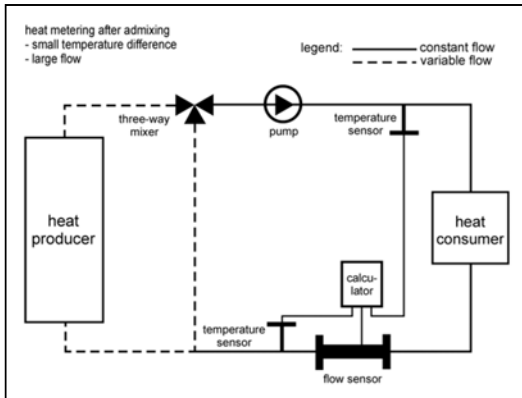

Fig. 1: Measurement after admixing

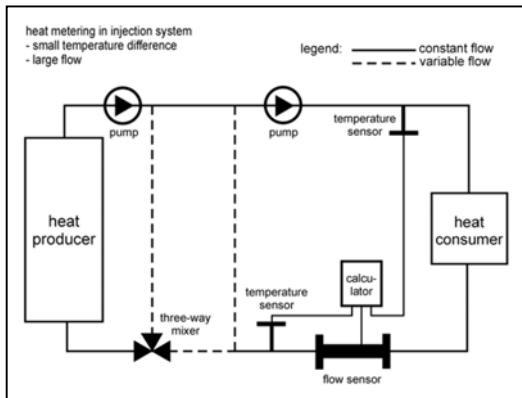

Fig. 2: Measurement in injection system

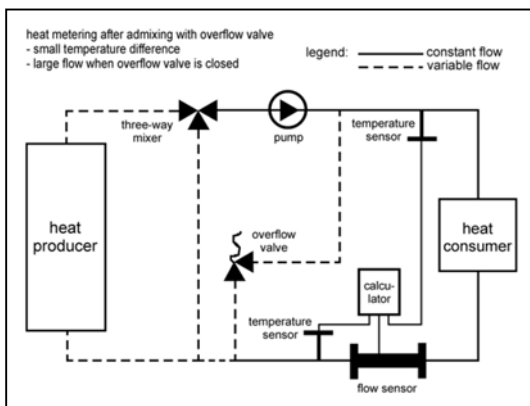

Fig. 3: Measurement with overflow valve

## 4.2 Installation of temperature sensors

PolluStat is operated with separately approved and paired temperature sensors type Pt 500. The applicable type is specified on the integrator front side.

The two temperature sensors can optionally be mounted in thermo wells or directly into the heating or cooling liquid. We recommend using ball valves in order to facilitate future exchange.

For a general installation standard please refer to EN 1434-2.

For temperature sensor type 45 mm x 5.2 mm (length x diameter) and DS 27.5 acc. to EN 1434-2 we recommend the installation in our ball valves with temperature sensor retainer M 10 x 1 or complete installation kits including fitting pieces and thread connections (please refer to data sheet LH 4110 INT).

For Sensus temperature sensors of the overall lengths 100 mm and 150 mm, the sensitive zone is approximately 10 to 15 mm measured from the temperature sensor's tip and has to be positioned as near as possible to the **middle of the pipe diameter**. Refer to the following guide for installing such temperature sensors:

Nominal sizes  $\leq$  DN 50\*:  
Mount the temperature sensors in an angle of 45° (see fig. 4).

\* For DN  $\leq$  50 an installation in a bent tube is also possible.

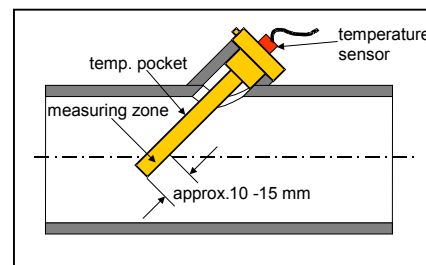

Fig. 4: Exemplary diagram  
for nominal size  $\leq$  DN 50

### 4.3 Mounting of the integrator

PolluStat E is delivered with the integrator mounted on the flow sensor. Depending on the flow sensor's installation (horizontal or vertical) the integrator can be turned through steps of 90 degrees. Lift the spring catch with a screw driver and take the integrator from the carrier plate. Then turn the integrator to the required position, adjust it to the bottom edge of the carrier plate, lift the spring catch, attach the integrator onto the carrier plate and release the spring catch.

**If liquid temperatures exceed 90°C the integrator has to be mounted separately, in order to avoid damages of electronic parts.**

Lift the spring catch with a screw driver and take the integrator from the carrier plate and fix it at the required place using the two screws and the two enclosed dowels.

### 4.4 Connection of temperature sensors

The applicable temperature sensor type is Pt 500 for the PolluStat. The required minimum distance from sources of electromagnetic interference (generators, frequency converters ...), as well as from cables carrying  $\geq 230$  V, is 0.3 m. The connection is possible in two-wire technology. Allocation as follows:

#### Supply pipe temperature sensor (warmer line):

Connection type	Terminals
Two-wire connection	5, 6

#### Return pipe temperature sensor (colder line)

Connection type	Terminals
Two-wire connection	7, 8

For connection of the temperature sensor cable pull it through a hole in the rubber part and provide the strain relief. Then connect the cores to the corresponding terminals (see fig. 5).



Fig. 5: Example of temperature sensor connection

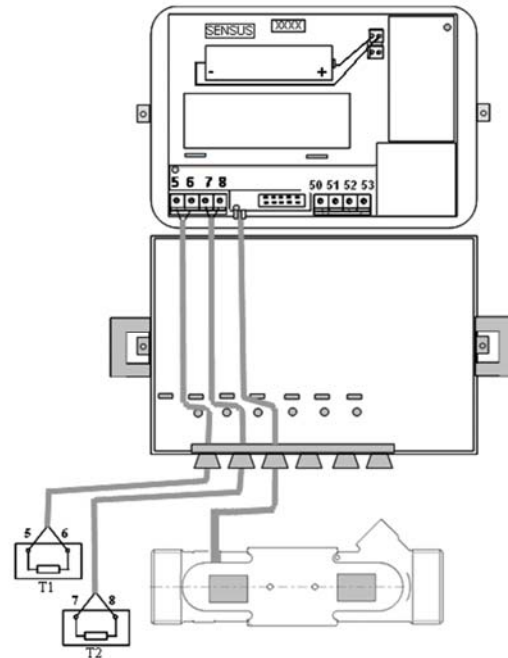

Fig. 6: electrical connection diagram

Temperature sensor types, which are delivered from the factory with already attached preshaped rubber parts (see. Fig. 7), have to be cut before using. Therefore cut the preshaped rubber part carefully with a side cutter and remove it from the cable.

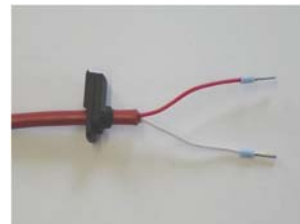

Fig. 7: Cable incl. already attached preshaped rubber part

**5. Display options**

The different display options of PolluStat E are divided into three menus. Depending on the type of the meter and the display masking respectively, some display items can be masked. If required, the masking can be changed via the optical data interface of the meter with a service software.

In the basic state the display is switched on and shows the accumulated energy. By a stroke on the yellow key the next display item is activated. The selection menu for the other two menus can be obtained by a pressure of 3 seconds onto the yellow key:

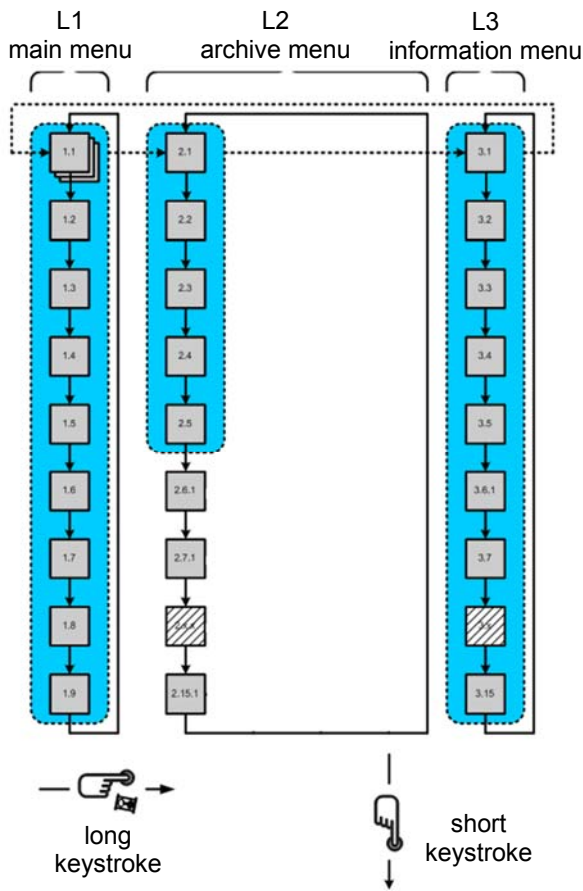

Fig. 7: Change of the Display menus

The menus can be selected in sequence by long strokes on the yellow key. As soon as the desired menu is displayed, left the yellow key in order to obtain this menu. Each one of the single display items in the menu will be called up one after the other by a short keystroke. If there is no key operation within four minutes, the display returns automatically to the normal condition. The shown value figures are to be considered exemplarily.

**5.1 Main menu (L1)**













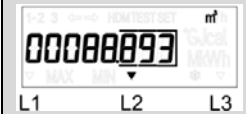

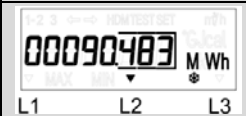









All display items are marked with an arrow symbol at L1.

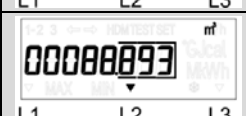



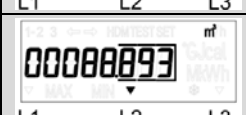

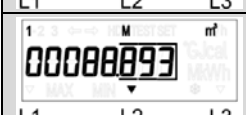
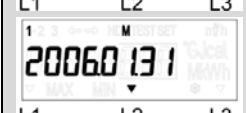

	Error message (only in case of error)
	Accumulated energy consumption (heat)
	Consumption cooling energy (only for combined heating / cooling meters)
	Consumption tariff 1 (if activated)
	Consumption tariff 2 (if activated)
	Accumulated volume
	Consumption of first external meter (optional)
	Consumption of second external meter (optional)
	Segment test
	Working hours (without an energy calculation error)
	Customer specific number
	Control number

# Heating / Cooling meter PolluStat Installation and operating instructions

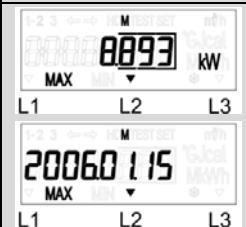
## 5.2 Archiv menu (L2)

All display items are marked with an arrow symbol at L2. Display of all stored values on an adjustable target date. And starting with the current date the values at the turns of the last month are displayed.



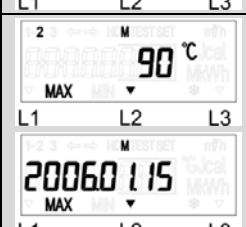
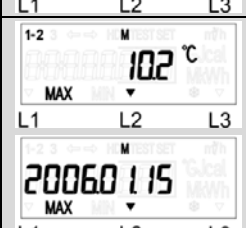









 L1 L2 L3  L1 L2 L3	<p>Energy consumption at set day</p> <p>associated date stamp (change every second)</p>	 L1 L2 L3  L1 L2 L3	<p>Consumption of the second external meter at set date (if activated)</p> <p>associated date stamp (change every second)</p>
 L1 L2 L3  L1 L2 L3	<p>Cooling energy at set date (only for combined heating / cooling meters)</p> <p>associated date stamp (change every second)</p>	 L1 L2 L3  L1 L2 L3	<p>Monthly value of Energy consumption</p> <p>associated date stamp (change every second)</p>
 L1 L2 L3  L1 L2 L3	<p>Consumption tariff 1 at set date (if activated)</p> <p>associated date stamp (change every second)</p>	 L1 L2 L3  L1 L2 L3	<p>Monthly value of Cooling energy (only for combined heating / cooling meters)</p> <p>associated date stamp (change every second)</p>
 L1 L2 L3  L1 L2 L3	<p>Consumption tariff 2 at set date (if activated)</p> <p>associated date stamp (change every second)</p>	 L1 L2 L3  L1 L2 L3	<p>Consumption tariff 1 at set date (if activated)</p> <p>associated date stamp (change every second)</p>
 L1 L2 L3  L1 L2 L3	<p>Volume at set date</p> <p>associated date stamp (change every second)</p>	 L1 L2 L3  L1 L2 L3	<p>Monthly value of tariff 2 (if activated)</p> <p>associated date stamp (change every second)</p>
 L1 L2 L3  L1 L2 L3	<p>Consumption of the first external meter at set date (if activated)</p> <p>associated date stamp (change every second)</p>	 L1 L2 L3  L1 L2 L3	<p>Monthly value of tariff 1 (if activated)</p> <p>associated date stamp (change every second)</p>
		 L1 L2 L3  L1 L2 L3	<p>Monthly value of the volume</p> <p>associated date stamp (change every second)</p>
			<p>Monthly value of the first external meter (if activated)</p> <p>associated date stamp (change every second)</p>





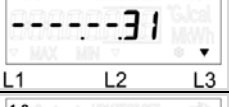

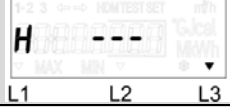

	<p>Monthly value of the second external meter (if activated)</p> <p>associated date stamp (change every second)</p>		<p>Monthly value of the minimum temperature difference</p> <p>associated date stamp (change every second)</p>
	<p>Monthly value of the maximum power</p> <p>associated date stamp (change every second)</p>		<p>Monthly value of the minimum temperature in return pipe</p> <p>associated date stamp (change every second)</p>
	<p>Monthly value of the minimum power</p> <p>associated date stamp (change every second)</p>		<p>Monthly value of the minimum temperature difference</p> <p>associated date stamp (change every second)</p>
	<p>Monthly value of the maximum flow rate</p> <p>associated date stamp (change every second)</p>		
	<p>Monthly value of the maximum temperature in supply pipe</p> <p>associated date stamp (change every second)</p>		
	<p>Monthly value of the maximum temperature in return pipe</p> <p>associated date stamp (change every second)</p>		
	<p>Monthly value of the maximum temperature difference</p> <p>associated date stamp (change every second)</p>		

# Heating / Cooling meter PolluStat Installation and operating instructions

## 5.3 Information menu (L3)

All display items are marked with an arrow symbol at L3.

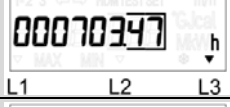
	Current power
	Current flow rate
	Current temperature in supply pipe
	Current temperature in return pipe
	Current temperature difference
	Next replacement date of the battery
	Current date
	Current time
	Yearly set day
	Monthly set day
	Configuration of the first tariff
	Configuration of the second tariff
	Configuration of the first external meter

	Configuration of the first external meter
	Heat meter fluid “---“ means water
	Pressure level “160E4“ means 16 Bar
	Customer specific number
	Software version
	Serial number
	Primary M-Bus address
	Working hours without a power calculation error
	Working hours in total

## 6. Functional test, sealing

Having opened the shut-off valves, test the installed units for leaks. For checking purposes the current values of flow rate, heating resp. cooling power as well as temperatures of warmer and colder line can be called to the display according to chapter 5.3. In order to protect the meter against tampering, the delivered selflock seals have to be attached to the following points:



- unions of the flow sensor
- insertion points of the temperature sensors
- lid of the integrator (pull the sealing wire through the lug on the side)

## 7. Possible error situations

PolluStat is equipped with an automatic self-checking function. As soon as an error is detected, the display shows a four-digit error code „Er XYZW“, which can be decoded as follows:

- X:** Checking the integrator  
**Y:** Checking the temperature sensor 2  
**Z:** Checking the temperature sensor 1  
**W:** Checking the ultrasonic measuring circuit

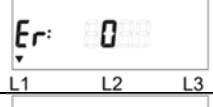
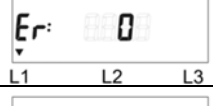
Auszug:

Codierung	Bedeutung
	0 – no error, normal operation 1 – warning, battery change is necessary 2 – temperature difference is greater than the limit 4 – temperature difference is less than the limit 8 – electronic failure
	0 – no error, normal operation 4 – temperature sensor 2 short cut 8 – Cable failure of temperature 2 or sensor is not connected
	0 – no error, normal operation 4 – temperature sensor 1 short cut 8 – Cable failure of temperature 1 or sensor is not connected
	0 – no error, normal operation 1 – no signal; air in flow sensor 2 – flow sensor in wrong direction 4 – flow is greater than 1.2x qmax 8 – electronic failure

The error message „Er xxx1“ („x“ stands for a figure from 0 to 8) means that no correct ultrasonic measurement occur (e.g. air in the flow sensor).

The error message „Er xxx2“ („x“ stands for a figure from 0 to 8) means that the flow sensor is installed upside down.

If nominal flow rate is exceeded by more than approx. 2,4 x qp, following error message is displayed:

„Er xxx4“

(„x“ stands for a figure from 0 to 8)

After reducing the flow, this message will disappear.

## 8. Standard interfaces and optional modules

PolluStat is equipped with following interfaces and can have the following optional equipment's:

### 8.1 Optical interface

All meters are equipped with a standard optical data interface. Via optical data coupler (e.g. order number 184023 for USB connection) settings can be changed with a service software, or the meter can be read out via the readout system DOKOM. The data interface is activated for 5 minutes by a short keystroke. Every data communication causes this period of time starts again, so that logger readout is possible over a long period of time.

### 8.2 M-Bus plug-in module acc. to EN 13757-3

(Order number: 68505124)

This plug-in module allows readout of the meter via its primary or secondary address with an M-Bus level converter (2400 Baud). Both addresses can be set with the service software (General information: The factory presetting of the secondary address and the customer number corresponds to the serial number shown on the meter casing). The primary address can be set to between 0 and 250, and is preset in the factory to 0. Polarity of the two connection terminals (24 and 25) can be neglected.

### 8.3 Mini-Bus plug-in module

(Order number: 68505132)

With this plug-in module it is suitable to connect the meter with an inductive readout point (MiniPad) or other reading and transmitting instruments (e.g. radio transponders). The Mini-Bus interface is available at terminals 51 (signal) and 52 (ground). The total length of the two-wire cable between the meter and the readout point must not exceed 50 m. The communication protocol corresponds to the M-Bus protocol, and the meter can be read out via a MiniReader or using DOKOM.

## 8.4 Remote pulse Output / Input

The heat meter has two open-collector remote pulse outputs which can be configured with the following parameters:

- heat quantity
- volume
- tariff register

Pulse duration: approx. 100 ms  
 Max. voltage: 50 V DC  
 Max. current: 0,02 A  
 Bounce-free

Pulse values:

Nominal size $q_p$ (m <sup>3</sup> /h)	Pulse value for energy (MWh)	Pulse value for volume (litres)
0,6 bis 2,5	0,001	1
3,5 bis 6	0,001	2
10	0,001	5

On delivery the heat meter is configured with two outputs. With a jumper the outputs can be converted to inputs. Commercial jumper from the computer industry with a pitch of 2.54 mm can be used (not included). The two right-hand plug options are provided for internal use and may not be used.

Numbering of the clamps:

clamp no.	description
5	temperature sensor warmer pipe (supply pipe), (T1)
6	temperature sensor warmer pipe (supply pipe), (T1)
7	temperature sensor colder pipe (return pipe) (T2)
8	temperature sensor colder pipe (return pipe) (T2))
50	GND for 2 <sup>nd</sup> additional pulse input or output
51	2 <sup>nd</sup> additional pulse input or output (In2 / Out2) (Volume output)
52	GND for 1 <sup>st</sup> additional pulse input or output
53	1 <sup>st</sup> additional pulse input or output (In1 / Out1) (Energy output)

Meaning of the jumper:

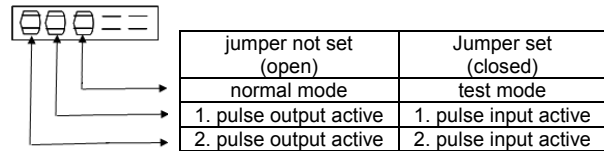

The configuration of the inputs has to be done via the service software. The consumption of the pulse meters is transferred in the M-Bus protocol of the heat meter.

## 8.5 Inserting the plug into the heat meter

In each processing unit is a slot for a module. The mounting of the plug in modules may only be permitted in the designated slots.

The pins must not be bent and slide easily into the appropriate contact sockets.

For communication modules a separate battery is included, which must be plugged into the heat meter.

Route the connecting cable through an available cable fitting and connect the wires to the respective terminals. Then make the pull relief.

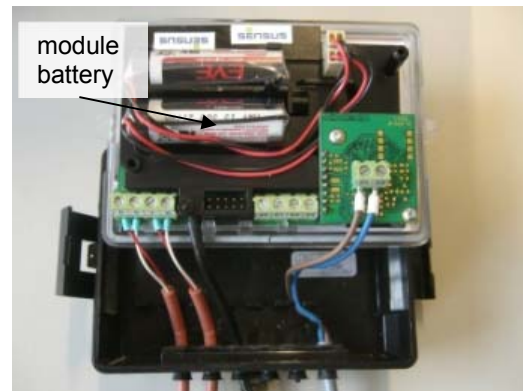

Fig. 8: Mounted module

## 8.6 Integrated data logger

The integrated data logger stores up to 1480 hourly values, up to 1130 daily values and up to 36 monthly values.

The logger data could be read out with the optical interface, M-Bus or Mini-Bus with the service-software.



Date: 20. June 2017

**EU Declaration of Conformity**  
**No CE/PolluStat/0617**

Herewith we,

Sensus GmbH Ludwigshafen  
Industriestr. 16  
67063 Ludwigshafen

declare under our sole responsibility, that the heat meter type **PolluStat**, to which this declaration relates, is in conformity with the following legal regulations:

Directive 2014/32/EU of the European Parliament and the Council of the 26<sup>th</sup> of February 2014, including

- Annex I, Essential requirements
- Annex VI, Thermal Energy Meters (MI-004)

Directive 2014/30/EU of the European Parliament and the Council of the 26<sup>th</sup> of February 2014

applied harmonized or normative documents

- OIML-R 75, Edition 2002
- DIN EN 1434, Edition 2016
- DIN EN 55022, Edition 2010

other standards

- WELMEC guideline 7.2, Edition 2015
- EN 60751, Edition 2009
- EN 13757-2, Edition 2005
- EN 13757-3, Edition 2013
- DIN EN ISO 4064-4, Edition 2014
- DIN EN 60529, Edition 2014
- DIN EN 60870, Edition 2006

The conformity assessment procedure was carried out under the supervision of the notified body LEI identification number 1621. The type-examination certificate LT-1621-MI004-015 was issued.

This declaration is made on behalf of the manufacturer by the Technical Director.

Sensus GmbH Ludwigshafen

Roland Rott  
Managing Director

Jürgen Westphal  
Director Metrology

Sensus GmbH Ludwigshafen  
Bankverbindung: Deutsche Bank Ludwigshafen  
Konto: 024 913 600 (BLZ 545 700 94)  
www.sensus.com

Telefon: + 49 (0) 621 / 6904 – 0  
Telefax: + 49 (0) 621 / 6904 – 1490  
Amtsgericht: Ludwigshafen HRB 5153  
Geschäftsführung:  
Aufsichtsratsvorsitzender:

Industriestraße 16  
D-67063 Ludwigshafen  
Ust-Id-Nr.: DE 160261426  
Peter Karst, Roland Rott  
Christopher Dühnen





**qualityaustria**  
Succeed with Quality

Certified according to ISO 9001  
Quality Management System Quality Austria Reg.no. 3496/0

Edition: 005, June 2017  
Subject to changes  
Sensus GmbH Ludwigshafen  
Industriestraße 16  
D-67063 Ludwigshafen

Phone: + 49 (0) 621 6904-1000  
Fax: + 49 (0) 621 6904-1409  
E-Mail: [info.int@xylem.com](mailto:info.int@xylem.com)  
[www.sensus.com](http://www.sensus.com)