

## VAG BEV-E Automatic Air Valve



# Content

<b>1</b>	<b>General</b>	<b>3</b>
1.1	Safety	3
1.2	Proper use	3
1.3	Identification	3
<b>2</b>	<b>Transport and Storage</b>	<b>3</b>
2.1	Transport	3
2.2	Storage	4
<b>3</b>	<b>Product features</b>	<b>4</b>
3.1	Features and function description	4
3.2	Applications	4
3.3	Performance limits	4
3.3.1	Minimum pressure	4
3.3.2	Venting performance data	4
<b>4</b>	<b>Installation into the pipeline</b>	<b>4</b>
4.1	Conditions required on site	4
4.2	Installation location	5
4.3	Installation position	5
4.4	Assembly instructions and fittings	5
<b>5</b>	<b>Set-up and operation of the valve</b>	<b>5</b>
5.1	Visual inspection and preparation	5
5.2	Function check and pressure test	5
<b>6</b>	<b>Maintenance and repair</b>	<b>6</b>
6.1	General safety instructions	6
6.2	Inspection and operation intervals	6
6.3	Design	7
<b>7</b>	<b>Trouble-shooting</b>	<b>7</b>
<b>8</b>	<b>How to contact us</b>	<b>8</b>

VAG reserves the right to make technical changes and use materials of similar or better quality without express notice. Pictures are non-binding.

# 1 General

## 1.1 Safety



These Operation and Maintenance Instructions must be observed and applied at all times along with the general "VAG Installation and Operation Instructions for Valves" (see [www.vag-group.com](http://www.vag-group.com) / Category: Installation and Operation Instructions).

Arbitrary alterations of this product and the parts supplied with it are not allowed. VAG will not assume any liability for consequential damage due to non-compliance with these instructions.

When using this valve, the generally acknowledged rules of technology have to be observed (e.g. international standards DIN standards, DVGW data sheets W 334 (aeration and venting drinking water pipes), W 392 (pipe inspection) and VDI directives, etc.).

The installation must only be carried out by qualified staff (see also Section 7.1 General safety instructions). For further technical information such as dimensions, materials or applications, please refer to the respective documentation (KAT-A 1943).

VAG valves are designed and manufactured to the highest standards and their safety of operation is generally ensured in general. However, valves may be potentially dangerous if they are operated improperly or are not installed for their intended use.

All persons dealing with the assembly, disassembly, operation, maintenance and repair of the valves must have read and understood the complete Operating and Maintenance Instructions (Accident Prevention Regulations, VBG 1 §§ 14 and following [Regulations issued by the Trade Associations] and ANSI Z535).

Before removing any protective devices and/or performing any work on the valves, depressurise the pipeline section and ensure it is free of hazards. Unauthorised, unintentional and unexpected actuation as well as any hazardous movements caused by stored energy (pressurised air, water under pressure) must be prevented.

In the case of equipment that must be monitored and inspected, all relevant laws and regulations, such as the Industrial Code, the Accident Prevention Regulations, the Ordinance of Steam Boilers and instructional pamphlets issued by the Pressure Vessels Study Group must be complied with. In addition, the local accident prevention regulations must be observed.

When a valve needs to be dismantled from a pipeline, fluid may emerge from the pipeline or the valve. The pipeline must be emptied completely before the valve is dismantled. Special care needs to be taken in case of residues which may continue flowing.

## 1.2 Proper use

VAG BEV-E Automatic Air Valve is a valve with a female screw thread for screwing to the pipeline.

The standard type is suitable for the automatic aeration and venting of water supply systems.

For the respective technical application ranges (e.g. operating pressure, medium, temperature) please refer to the specific product-related documentation (KAT-A 1943).

Before any deviation from normal operating conditions and applications, the manufacturer's written approval must be obtained!

These Operation and Maintenance Operation Instructions contain

important information on the safe and reliable operation of the VAG BEV-E Automatic Air Valve.

Observing these Operation and Maintenance Instructions helps you to:

- Prevent hazards
- Reduce repair costs and down-times of the valve and/or the entire plant
- Improve the operational safety and useful life expectancy of the equipment.

## 1.3 Identification

According to DIN EN 19 all valves bear an identification label specifying the nominal diameter (DN), nominal pressure (PN), body material and the manufacturer's logo.

A rating plate is attached to the body and contains at least the following information:

VAG	Manufacturer's name
DN	Nominal diameter of the valve
PS	maximum admissible operating pressure
	Date of manufacture

# 2 Transport and Storage

## 2.1 Transport

For transportation to its installation site, the valve must be packed in stable packaging material suitable for the size of the valve. Ensure that the valve is protected against atmospheric influences and external damage. When the valve is shipped under specific climatic conditions (e.g. overseas transport), it must be specially protected and wrapped in plastic film and a desiccant must be added.

The factory-applied corrosion protection and any assemblies must be protected against damage by external influences during transport and storage.

The VAG BEV-E Automatic Air Valve must be transported and stored in a secure transport position.

For valves that have been factory-packed in transport crates (wooden crates), the centre of gravity of the entire unit must be taken into account. The centre of gravity is marked on each side of the crate at our factory and must be considered for all lifting operations.

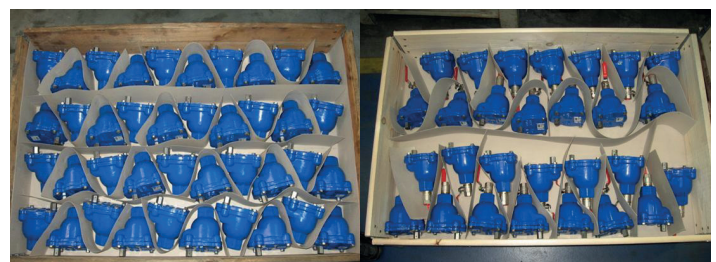

Figure 1: Transport position

## 2.2 Storage

The elastomeric parts (seals) must be protected against direct sunlight and/or UV light as otherwise their long-term sealing function cannot be guaranteed. Store the valve in a dry and well-aerated place and avoid direct radiator heat.

Storing product in sunlight and / or UV light will cause a chalking of the epoxy coating.

Protect the Air Valve against dust and other dirt by adequate covering.

Do not remove the protective caps of the connections / flanges and the packaging materials until immediately prior to assembly.

The valve can be stored in ambient temperatures ranging from -20 °C to + 50 °C (protected by adequate covers). If the valve is stored at temperatures below 0 °C, it should be warmed up to at least +5° C before installation and before it is put into operation.

## 3 Product features

### 3.1 Features and function description

The VAG BEV-E Automatic Air Valve is a single-chamber air valve for the automatic aeration and venting of pipe-lines.

Two venting functions are possible:

- Small orifice to release low quantities of air during operation under pressure
- Small orifice to vent low quantities of air

The VAG BEV-E is available with ball valve as an option. The optional ball valve will isolate the VAG-BEV-E for inspection.

### 3.2 Applications



Figure 2: Versions

The VAG BEV-E Automatic Air Valve can be used for the following media:

- Water
- Raw water and cooling water

The use of media containing oil and gas may cause the destruction of the sealing rings and the O rings and is therefore not permissible.

The VAG BEV-E Automatic Air Valve should only be used in media in which there is no risk of clogging.

For information about the corresponding temperature limits, please refer to the product-related technical documentation (KAT -A 1943).

In case of deviating operating conditions and applications, please consult the manufacturer.

## 3.3 Performance limits

### 3.3.1 Minimum pressure

The minimum pressure for sealing the venting cross-sections is 0,5 bar.

### 3.3.2 Venting performance data

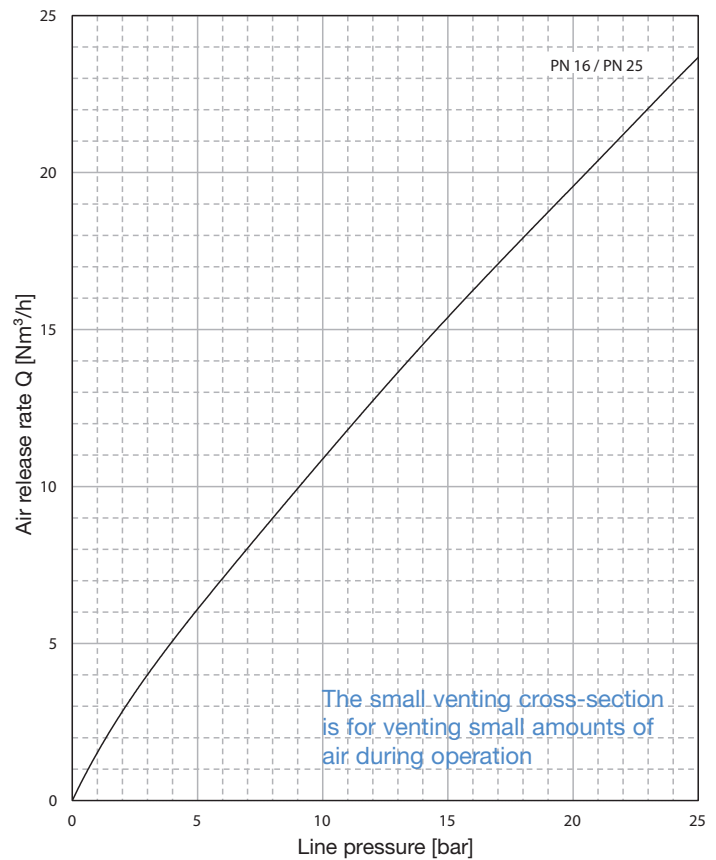

Figure 3: Performance data

## 4 Installation into the pipeline

### 4.1 Conditions required on site

When installing connection pipe with male thread must be vertical.

Venting valves should be installed as close as possible to the pipe being vented to avoid long supply lines from collecting stagnated water (hygienic problems). In addition, long supply lines may result in limited venting function.

For assembly in drinking water pipelines, suitable sealing materials, lubricants and process materials must be used which are approved for use in drinking water pipelines.

## 4.2 Installation location

The location of the valve must be selected to provide sufficient space for function checks and maintenance works (e.g. dismantling and cleaning of the valve).

If the valve is installed outdoor, it must be protected against extreme atmospheric influences (e.g. formation of ice etc.) with adequate covers.

## 4.3 Installation position

The VAG BEV-E Automatic Air Valve must always be installed in an upright position. If installed in any other position, the manufacturer cannot ensure the trouble free functioning of the valve or station (see figure 4).

## 4.4 Assembly instructions and fittings

Check the valve for possible damage that may have occurred during transport or storage. Protect the valve against dirt from the construction site by adequate covering until installation. Prior to installation all components essential for proper function, such as the thread must be thoroughly cleaned to remove all dirt particles. VAG does not assume any liability for consequential damage caused by dirt, shot-blasting gravel residue etc.

The functional parts should be checked for proper operation prior to installation.

Should the valves be repainted on site, it must be ensured that no paint is applied to the functional parts. The identification plates must not be painted. If the equipment is sand-blasted for any reason prior to installation, these parts must be adequately covered. If solvents are used for cleaning, ensure that they do not damage the seals of the pipeline or the valve.

When installing the valve, it must be ensured that the threaded connection (BEV-E) to the pipeline is aligned and parallel. Welding work on the pipeline needs to be performed prior to the installation of the valves to prevent damage to the seals and the corrosion protection. Welding residues must be removed before the valves are going into service.

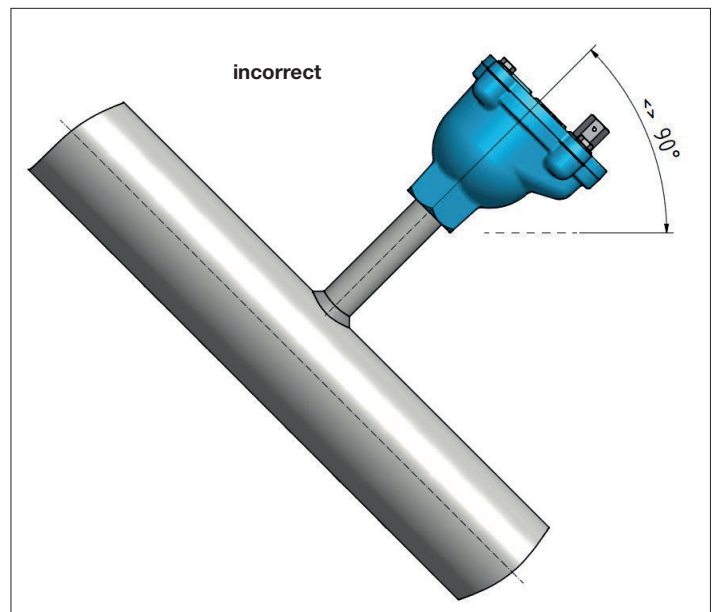

## 5 Set-up and operation of the valve

### 5.1 Visual inspection and preparation

Before startup of the pipe system, perform a visual inspection of all functional parts. Check whether all connections have been properly fastened.

### 5.2 Function check and pressure test

Prior to installation the isolating ball valve shall be closed and opened once and should be checked for trouble-free operation.

Warning!! The pressure exerted on the closed valve must not exceed its nominal pressure (see technical data sheet KAT-A 1943). When a pressure test is performed in the pipeline with a test pressure exceeding the admissible nominal pressure in closing direction, the pressure must be compensated by way of a bypass.

If detergents or disinfectants are used it must be ensured they do not attack the valve materials.

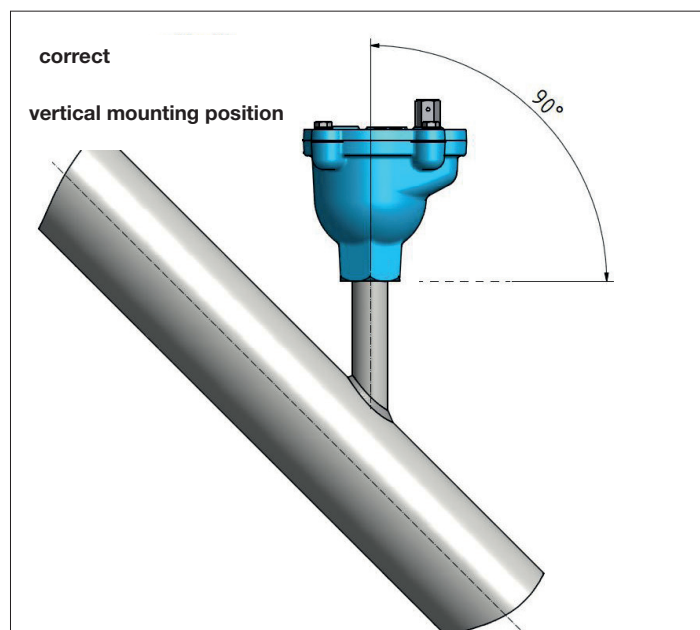

Figure 4: Assembly position

### 6.1 General safety instructions

Prior to the performance of inspection and maintenance work on the valve or its assemblies, shut-off the pressurised pipeline, depressurise it and secure it against inadvertent activation. Depending on the type and hazard risk of the fluid conveyed, comply with all required safety regulations!

After completing the maintenance works and before resuming operation, check all connections for tightness. Perform the steps described for initial set-up as described under Section 5 "Set-up and operation".

Statutory and local laws as well as the safety and accident prevention regulations must be observed and complied with at all times.

Couplings and connections must never be disassembled when they are under pressure.

Servicing, maintenance and inspection work as well as the replacement of spare parts must be carried out by qualified personnel. The plant operator is responsible for determining the suitability of the personnel or for ensuring that they have all relevant qualifications.

In case the operator's employees do not have the qualifications required, they should attend a training course. Valve related training courses can be undertaken by VAG Service employees.

In addition to this, the plant operator needs to ensure that all employees have understood these Operation and Maintenance Instructions as well as all further instructions referred to in them.

Protective equipment such as safety boots, safety helmets, goggles, protective gloves etc. must be worn during all work requiring such protective equipment or for which such protective equipment is prescribed.

Improper or wrong use of the valve must be avoided. Prior to the performance of any work on the valve and equipment it must be ensured that the relevant pipeline section has been depressurised and/or de-energised.

### 6.2 Inspection and operation intervals

The VAG BEV-E Automatic Air Valve is virtually maintenance-free. The valve should however be inspected within a period of one year according to German DVGW data sheet W 392).

In case of extreme operating conditions inspection should be performed frequently.

Depending on the type of medium, the body seal may be replaced whenever necessary.

Before any maintenance work is performed on the VAG BEV-E Automatic Air Valve, the valve must be shut off by an inspection valve and must be depressurised using screw on bonnet.

**Warning:** Open carefully screws on bonnet. The pressure is relieved via the release gasket between body and bonnet. Maintenance work must not be performed before this has been done.

## 6.3 Design

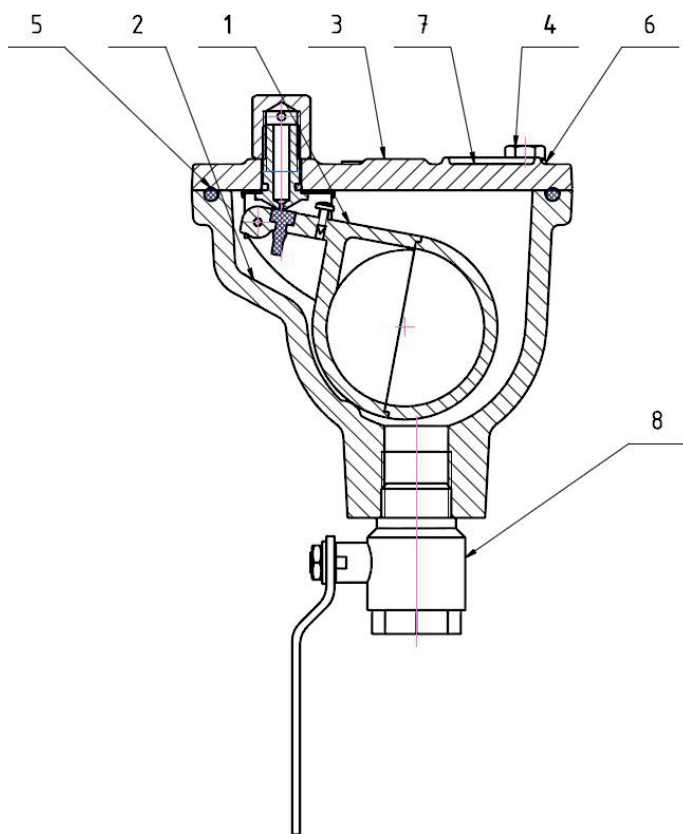

Item	Designation	Material
1	Float	Plastic
2	Body	EN-GJS-400-15
3	Cover	EN-GJS-400-15
4	Hexagon screw	A2-70
5	Sealing ring	NBR
6	Washer	A2-70
7	Label	-
8	Ball valve	Brass

## 7 Trouble-shooting

For all repair and maintenance work, please observe the general safety instructions described in Section 6.1!

Problem	Cause	Remedial action
Valve is making noises	Unfavourable installation position, therefore unfavourable flow around the valve (e.g. installed too close to an elbow etc.)	Change installation position
	Valve is releasing air	Too much air in pipe system select bigger size for air valve
Leaking valve	Sealing ring damaged	Replace sealing ring
Desired air release rate is not achieved	Too much air in system	<ul style="list-style-type: none"> <li>caused by problem in pipe system</li> <li>include more air valves in pipe system</li> </ul>

### **Head office**

VAG GmbH  
Carl-Reuther-Str. 1  
68305 Mannheim  
Germany

Phone: +49 (621) 749-0  
Fax: +49 (621) 749-2153  
info@vag-group.com  
<http://www.vag-group.com>

### **Service**

Our service hotline can be reached 24/7 world-wide. In case of emergency, please contact us by phone.

Service hotline: +49 621 - 749 2222

Service per email: [service@vag-group.com](mailto:service@vag-group.com)

