

PolluStat

Ultrasonic Meter
for heating and cooling energy
nominal sizes q_p 0.6 to 10 m³/h

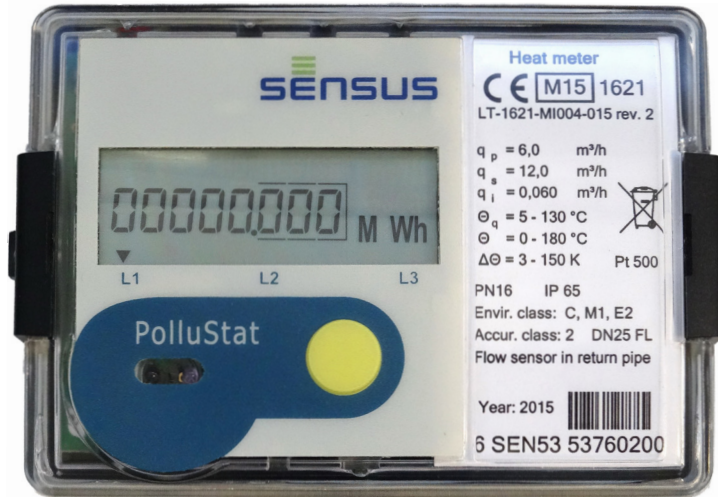

Application

The ultrasonic meter PolluStat is applicable for energy consumption measurement in heating or cooling circuits with water as the heat carrier.

Optionally PolluStat is available for the usage in combined heating and cooling systems, where an automatic switch-over point provides storing of heating and cooling energy in separate registers.

On account of its high-precision flow sensor the application range reaches from district heating to consumption billing for individual apartments.

Regarding meter remote reading and data communication the following modules are available:

- M-Bus according to EN 1434-3
- LONWORKS®-FTT10A

Special Features

- Approval in class 2 according to EN 1434, measuring range (minimum to nominal flow) of 1 : 100 in horizontal and vertical position
- Temperature range of the flow sensor from 5 to 130 °C, thus also ideal for so-called "6/12 °C cooling systems"
- Fast updating of measuring values
- Removable calculator for installation in narrow places
- Standard optical interface
- Programmable scope of displayed informations
- Programmable tariff register
- 2 standard bounce-free output pulses or inputs
- Integrated data logger

Integrator

PolluStat is equipped with an easy to read LC-display with eight-digit main reading line. Moreover some additional symbols support the readout.



Segment test

The available display items are clearly structured in 3 menus and include in substance:

L 1: Main menu

- Accumulated consumptions
- Segment test
- Instantaneous values (power, flowrate, temperatures)
- Customer's reference number

L 2: Archive menu

Consumption values at a programmable annual target day

L 3: Configuration menu

Rolling monthly storage of the following values for the last 16 months:

- Consumptions
- Volume of the heating resp. chilling liquid
- Maxima for power and flowrate
- Recorded failure hours

Upgrade Plugin Module

For electronic reading and connection to building management systems a upgrade plug-in module is available for PolluStat:

M-Bus according to EN 13757-3

Order number: 68 505 124

This plug-in module allows reading the meter via its primary or secondary address with an M-Bus level converter (2400 Baud). If required the M-Bus addresses can be changed at the meter itself.

LONWORKS®-FTT10A

Order number: 68 505 136

This plug-in module is used to implement the meter via LONTALK® protocol into a building automation system. For detailed informations please refer to data sheet LH 6132 INT.

Integrated remote reading pulses energy and volume

The meter provides bounce free remote reading pulses, which can be fed to a remote totalizer.

Closing time: approx. 100 ms

Bounce time: none

Max. voltage: 50 V DC

Max. current: 0.02 A

The pulse values of the flow sensor:

Nominal size q_p (m³/h)	Pulse value for energy (MWh)	Pulse value for volume (litres)	
		until 10/2015	from 11/2015
0.6 to 2.5	0.001	1	1
3.5 to 6	0.001	2	
10	0.001	5	10

Integrated data logger

Every hour, day and month values of the measured parameters are stored in the memory of the meter.

All data from archive can be read only by means of remote reading.

In addition data logger records of the last month can be seen on the display.

Following hourly, daily and monthly parameter values are recorded in the heat meter memory.

Data logger capacity:

up to 1480 h – for hourly records.

up to 1130 days - for daily records,

up to 36 last months - for monthly records,

Archive data storage time not less than 36 months

Storage time of measured integrated parameters even if device is disconnected from power supply not less than 15 years.

Technical Data of integrator

Temperature measuring range	$\Theta = 0 \dots 180 \text{ }^\circ\text{C}$
Temperature difference range	$\Delta\Theta = 3 \dots 150 \text{ K}$
Switch-off threshold	0.15 K
Measuring accuracy	better than $(\%) \pm (0.5 + \Delta\Theta_{\min} / \Delta\Theta)$
Optical data interface	Physical acc. to EN 61107 Data protocol acc. to EN 13757-3
Suitable temperature sensors	Pt 500 Connection in two wire technology
Connection cable length between integrator and flow sensor	1.2 m
Power supply	Battery for 11 years or mains supply 230 V AC resp. 24 V AC/DC
Electromagnetic environment condition	Class E 2
Mechanical environment condition	Class M 1
Protection class	IP 54
Permissible ambient temperature	5 ... 55 °C
Storage temperature	-20 ... +65 °C
Relative air humidity	< 93 % (non-condensating)
Size	

Technical data of flow sensor

Approvals	acc. EN 1434, class 2 Directive 2014/32/EU
Measuring accuracy	Better than: $\pm (2 + 0,02 q_p / q) \%$
Flow rate ratios	$q_i / q_p = 1 / 100$ $q_p / q_s = 1 / 2$
Straight inlet and outlet pipes	Not required acc. European Directive
Temperature range	5 ... 130 °C
Installation position	Any position, even head down
Electromagnetic environment condition	Class E 2
Mechanical environment condition	Class M 1
Exterior protection class of the ultrasonic probes (protection against water condensation in case of cooling meter)	IP 65

Order details for integrator sub-unit

Nominal sizes q_p 0.6 to 2.5

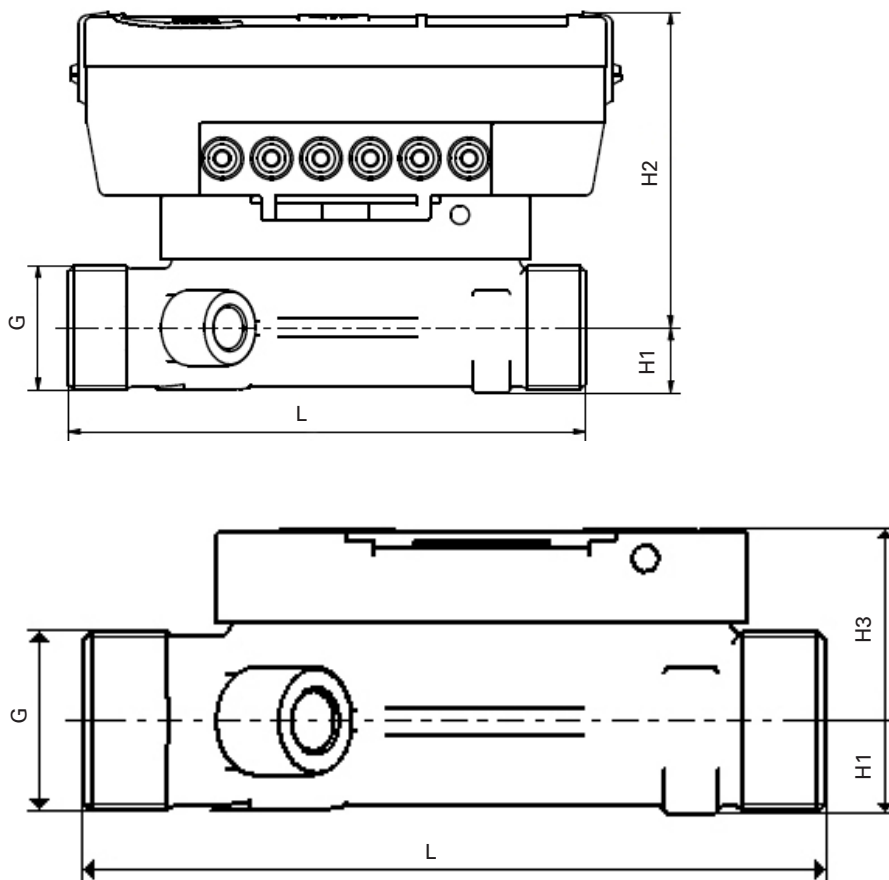

q_p (m ³ /h)	Version with thread connection					Version with flange connection	
	Meter thread G	L (mm)	H1 (mm)	H2 (mm)	H3 (mm)	D (mm)	L (mm)
0.6	¾"	110	14	67	28	91	190
	1"	190	18	68	29		
1.5	¾"	110	14	67	28		
	1"	190	18	68	29		
2.5	1"	130	18	67	28		
		190	18	68	29		

Nominal sizes q_p 3.5 to 10

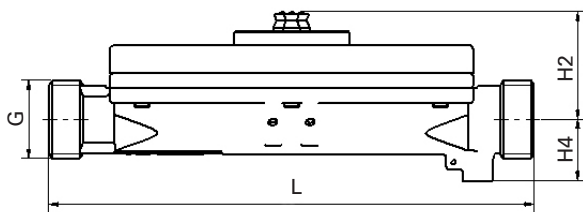
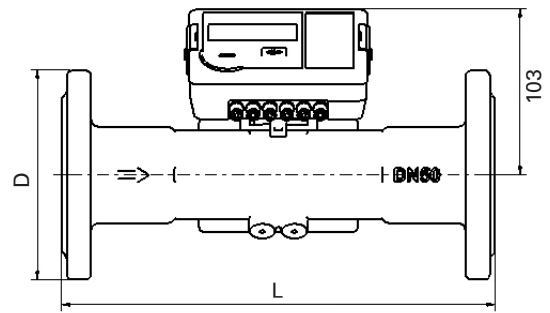
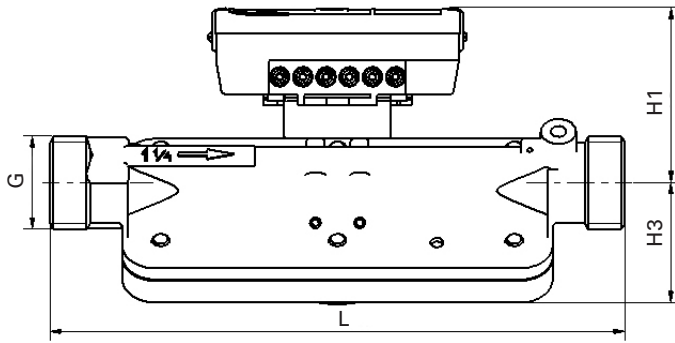

q_p (m ³ /h)	L (mm)	H 1 (mm)	G	H 2 (mm)	H 3 (mm)	H 4 (mm)	D (mm)
3,5	260	79	1 ¼"	58	54	33	115
6	260	79	1 ¼"	58	54	33	115
10	300	89	2"	53	51	32	120

Version with thread connection

Nominal size q_p (m ³ /h)	Minimum flow rate q_i (m ³ /h) acc. to approval	Maximum flow rate q_s (m ³ /h)	Body length (mm)	Nominal diameter	Meter thread	Pressure level PN (bar)
0.6	0.006	1.2	110	R 1/2" (DN 15)	G 3/4"	16
0.6	0.006	1.2	190	R 3/4" (DN 20)	G 1"	
1.5	0.015	3	110	R 1/2" (DN 15)	G 3/4"	
1.5	0.015	3	190	R 3/4" (DN 20)	G 1"	
2.5	0.025	5	130	R 3/4" (DN 20)	G 1"	
2.5	0.025	5	190	R 3/4" (DN 20)	G 1"	
3.5	0.035	7	260	R 1" (DN 25)	G 1 1/4"	
6	0.06	12	260	R 1" (DN 25)	G 1 1/4"	
10	0.1	20	300	R 1 1/2" (DN 40)	G 2"	

Version with flange connection (drilling scheme acc. to EN 1092)

Nominal size q_p (m ³ /h)	Minimum flow rate q_i (m ³ /h) acc. to approval	Maximum flow rate q_s (m ³ /h)	Body length (mm)	Nominal diameter	Pressure level PN (bar)
0.6	0.006	1.2	190	DN 20	16 or 25
1.5	0.015	3	190	DN 20	
2.5	0.025	5	190	DN 20	
3.5	0.035	7	260	DN 25	
6	0.06	12	260	DN 25	
10	0.1	20	300	DN 40	

Pressure loss curve

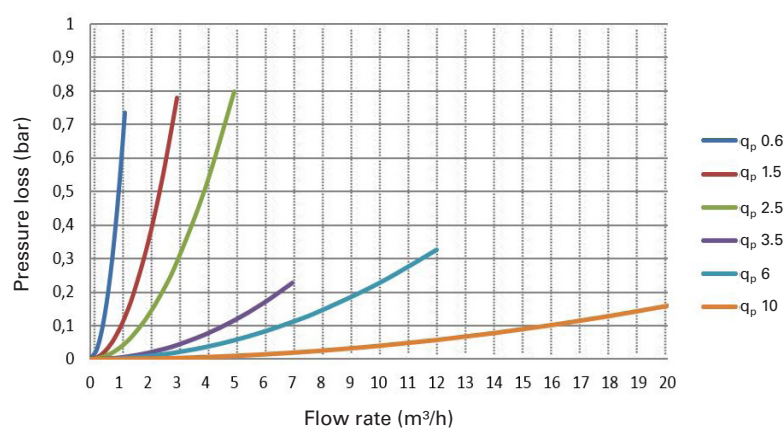

qualityaustria
Succeed with Quality

Certified according to ISO 9001
Quality Management System Quality Austria Reg.no. 3496/0

UK & Ireland Enquiries

Sensus UK Systems Ltd, 3 Lindenwood Crockford Lane, Chineham Business Park
Basingstoke RG24 8QY UK
T: +44 (0) 1256 372800 F: +44 (0) 1256 707203 Email: info.gb@xyleminc.com www.sensus.com

International Enquiries

Sensus GmbH Ludwigshafen, Industriestrasse 16, 67063 Ludwigshafen Germany
T: +49 (0) 621-6904-0 F: +49 (0) 621-6904-1409 Email: info.int@xyleminc.com www.sensus.com