

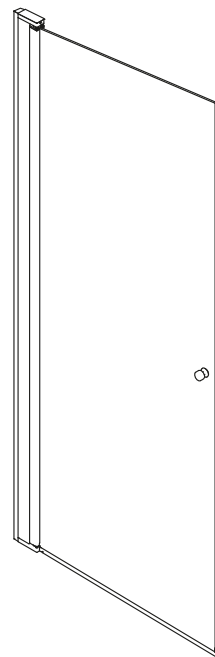

- SE Monteringsanvisning Square / Round Duschkörn och Nischdörr
 DK Monteringsanvisning Square / Round Brusedør og Nishedør
 NO Monteringsanvisning Square / Round Dusjdør og Nisjedør
 FI Asennusohje Square / Round Suihkuovi
 GB Installation instruction Square / Round shower door and Niche door
 EE Paigaldusjuhend Square / Round- ja Nišipaigaldusega Dušistele
 LV Uzstādīšanas instrukcija, Kvadrāta / Apaļās un Nišas Dušas durvis
 LT Montavimo instrukcija Square / Round - Pusapvalės dušo durys ir dušo durys į Nišą

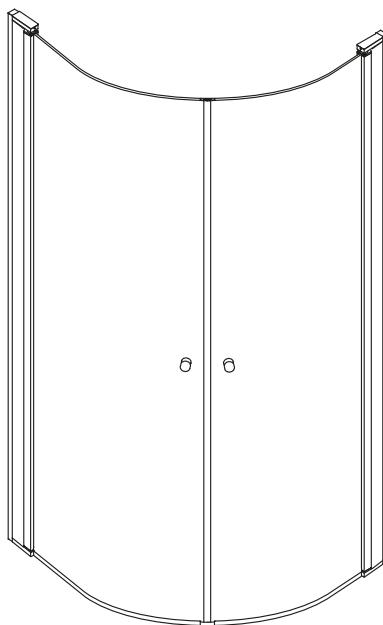

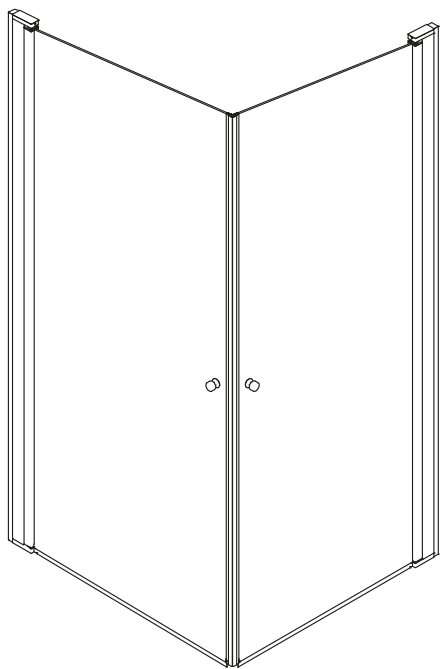





CE



Accepterad
 monteringsanvisning
 2026:1



	Garanti. Takuu. Guarantee. Garantii. Garantija. Garantija. Záruka.	2/16		5.16/16	
		3/16		Reservdelar. Reservedeler. Reservele. Varaosat. Spare parts. Varuosad. Atsarginės dalys. Rezerves daļas.	16/16
	Square & Round	4. 6-10/16		Drift & skötsel Drift og vedligeholdelse Drift og vedlikehold Asennus-, käyttö- ja hoito-ohjeet Assembly and maintenance Paigaldamine & hooldamine Montaza un kopsana Montavimas ir priežiūra	16/16
	Niche	3. 11-15/16			

SE GARANTI

Produkten har garanti enligt respektive lands gällande branschvillkor.

Direktiv vid reklamation.

Våra produkter är tillverkade enligt väldigt stränga kvalitetskrav. Om en produkt trots det är felaktig, ber vi er i första hand att kontakta din återförsäljare. Ärendet underlättas genom att uppvisa kvitto och uppge produktnummer och inköpsdatum.

DK GARANTI

Produktet har garanti i forhold til gældende dansk lovgivning.

Vejledning ved reklamation.

Vores produkter er fremstillet i overensstemmelse med markedets strengeste krav til kvalitet. Skulle produktet mod forventning være behæftet med fejl henviser vi til den forhandler, hvor produktet er købt. Kvittering skal kunne fremvises, hvis forhandleren forlanger det, ligesom oplysninger om produktnummer og købsdato skal kunne dokumenteres.

NO GARANTI

Produktene har garanti i henhold til respektive lands gjeldende bransjevilkår.

Instruksjer ved reklamasjon.

Våre produkter er produsert i henhold til veldig strenge kvalitetskrav. Om et produkt til tross for dette skulle være feilaktig, ber vi deg vennligst ta kontakt med forhandleren. Vi ber deg medbringe kvittering og oppgi innkjøpsdatasamt produktnummer.

FITAKUU

Noudatamme alamme yleisiä toimitusehtoja.

Reklamaatio.

Tuotteemme ovat valmistettu Villeroy & Boch ja Gustavsbergin laatuvaatimusten mukaisesti. Mikäli tuote kuitenkin on virheellinen pyydämme teitä kääntymään ensisijaisesti tuotteen myyjän puoleen. Käsittelyn helpottamiseksi säilyttäkää tosite tuotteen ostosta.

GB GUARANTEE

The product has a guarantee accordingly to industry rules in every country.

Instructions for complaints.

Our products are made according to very strict quality demands. If the product is faulty in spite of that we ask you kindly to take it to your retailer. We also ask you to bring the receipt and be prepared to inform about the product number and purchasing date.

EE GARANTII

Antud tootel on garantii vastavalt tehase poolt kehtestatud tingimustele.

Juhised reklamatsioonide käsitlemiseks.

Meie tooted on valmistatud silmas pidades väga täpseid kvaliteedistandardeid. Juhul kui olete saanud praaktoote, palume Teil toimetada see kas meie edasimüüja juurde või võtta ühendust esindusega. Samuti palume alles hoida ostutšekk ning vajadusel anda informatsiooni tootenumbri ja ostu sooritamise aja kohta.

LV GARANTIJA

Izstrādājumam ir garantija saskaņā ar ražotāja standartiem.

Instrukcija kvalitātes problēmu gadījumā.

Mūsu produkcija tiek ražota pēc ļoti striktiem kvalitātes kritērijiem. Taču – gadījumā, ja produktam tiek konstatēta kvalitātes problēma – lūdzu, sazinieties ar pārdevēju. Lūdzu, esiet gatavi arī uzrādīt pirkuma čeku ar pirkuma datumu.

LT GARANTIJA

Gaminiamis garantija suteikiama atsizvelgiant į , konkrečios šalies kokybės reikalavimus.

Reklamacijos.

Mū su, produkcija pagaminta vadovaujantis griežtais kokybės reikalavimais. Jei gaminys nekokybiškas – prašome jį , gražinti pardavėjui, pateikiant pirkimo čekį , gaminio numerį, bei nurodant pirkimo datą.



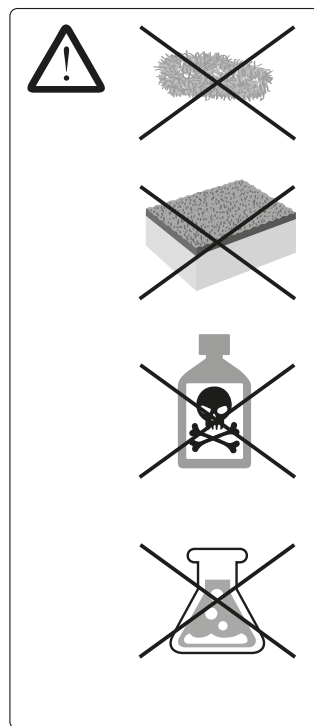
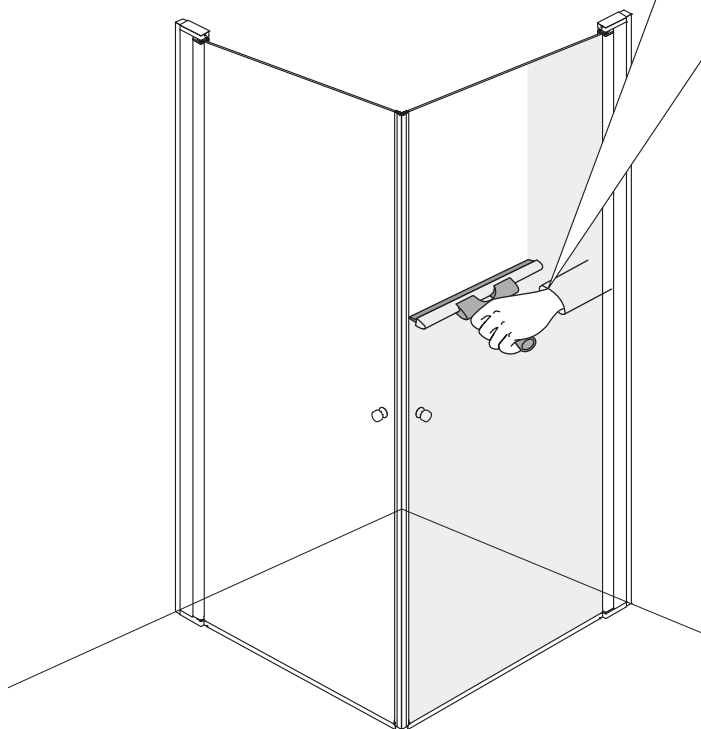

SQUARE NICHE

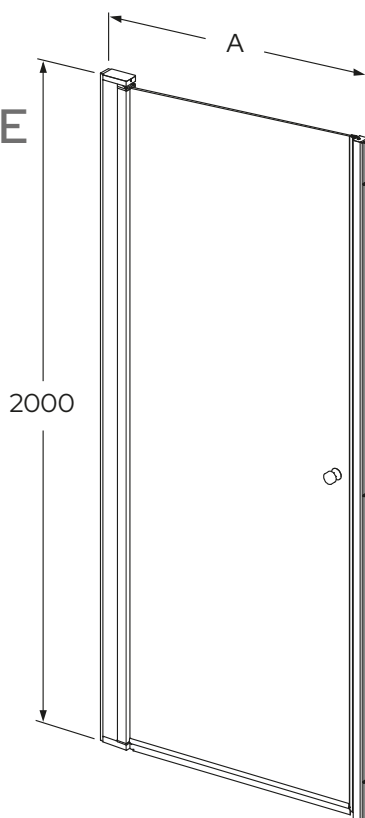

	A:
800	796-826
900	896-926
1000	996-1026



ROUND

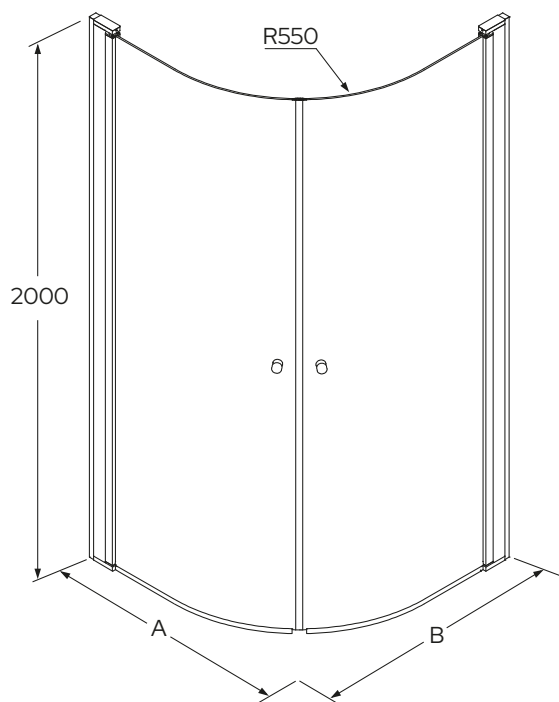

	A:	B:
800 x 800	790-810	790-810
900 x 900	890-910	890-910
1000 x 1000	990-1010	990-1010
800 x 900	790-810	890-910
800 x 1000	790-810	990-1010
900 x 800	890-910	790-810
900 x 1000	890-910	990-1010
1000 x 800	990-1010	790-810
1000 x 900	990-1010	890-910



SQUARE

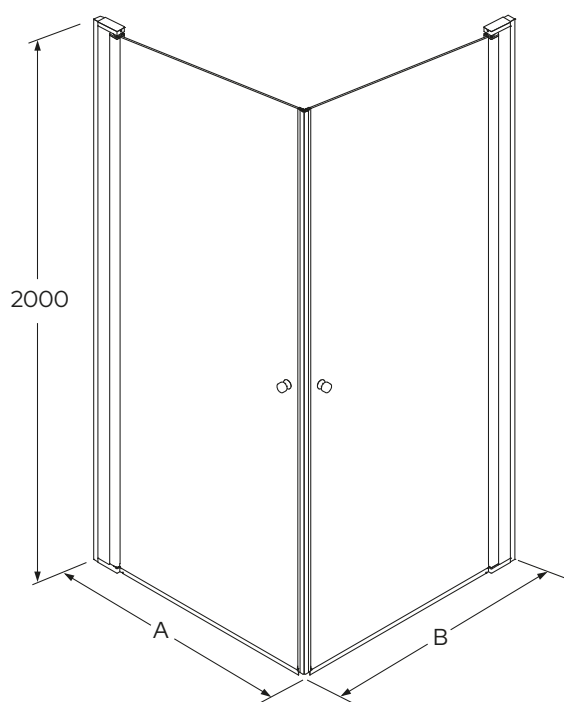

	A:	B:
800 x 800	790-810	790-810
900 x 900	890-910	890-910
1000 x 1000	990-1010	990-1010
800 x 900	790-810	890-910
800 x 1000	790-810	990-1010
900 x 800	890-910	790-810
900 x 1000	890-910	990-1010
1000 x 800	990-1010	790-810
1000 x 900	990-1010	890-910



SE. Enligt Branschregler
Säker Vatteninstallation

Kraven på infästning och tätning gäller i våtzone. Alla skruvinfästningar ska göras i massiv konstruktion, t ex i betong, i regler eller särskild konstruktionsdetalj. Skruv- infästningar får inte göras enbart i golv- eller väggskiva.

SILICON
EN 15651-3. Class XS1

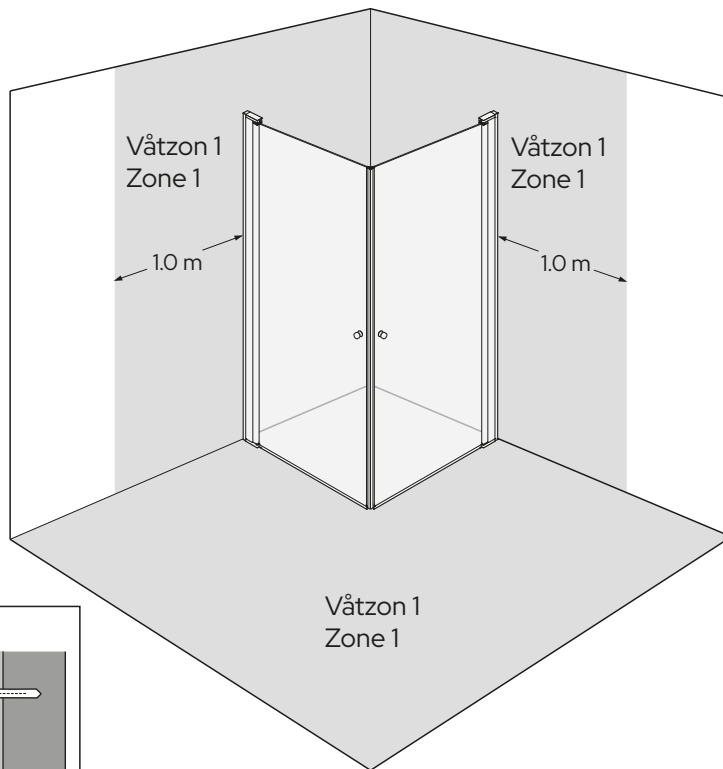

Trä Zon 1

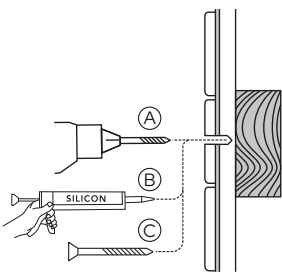

Betong Zon 1

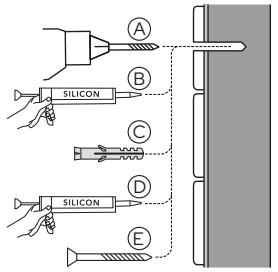

ROUND / SQUARE

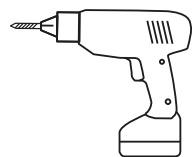
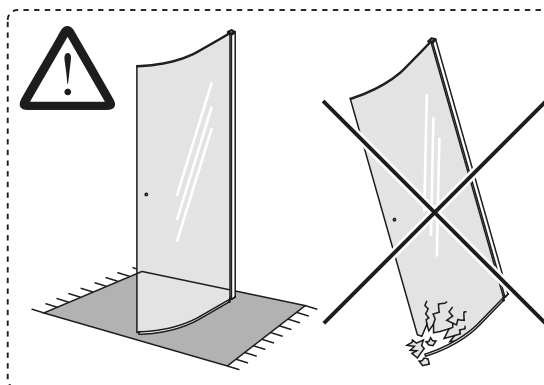
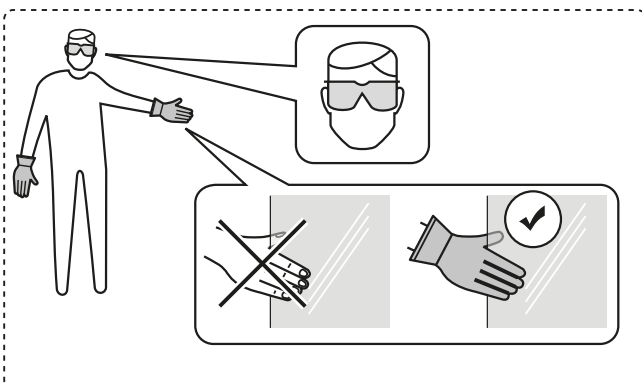

SILICON
EN 15651-3. Class XS1

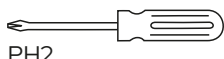

PH2

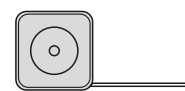

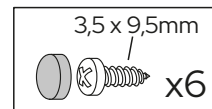
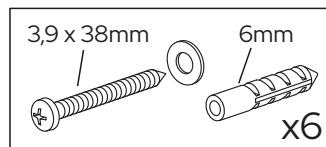
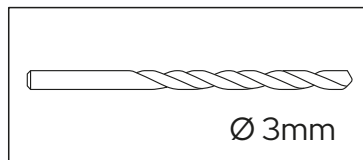

ROUND /
SQUARE

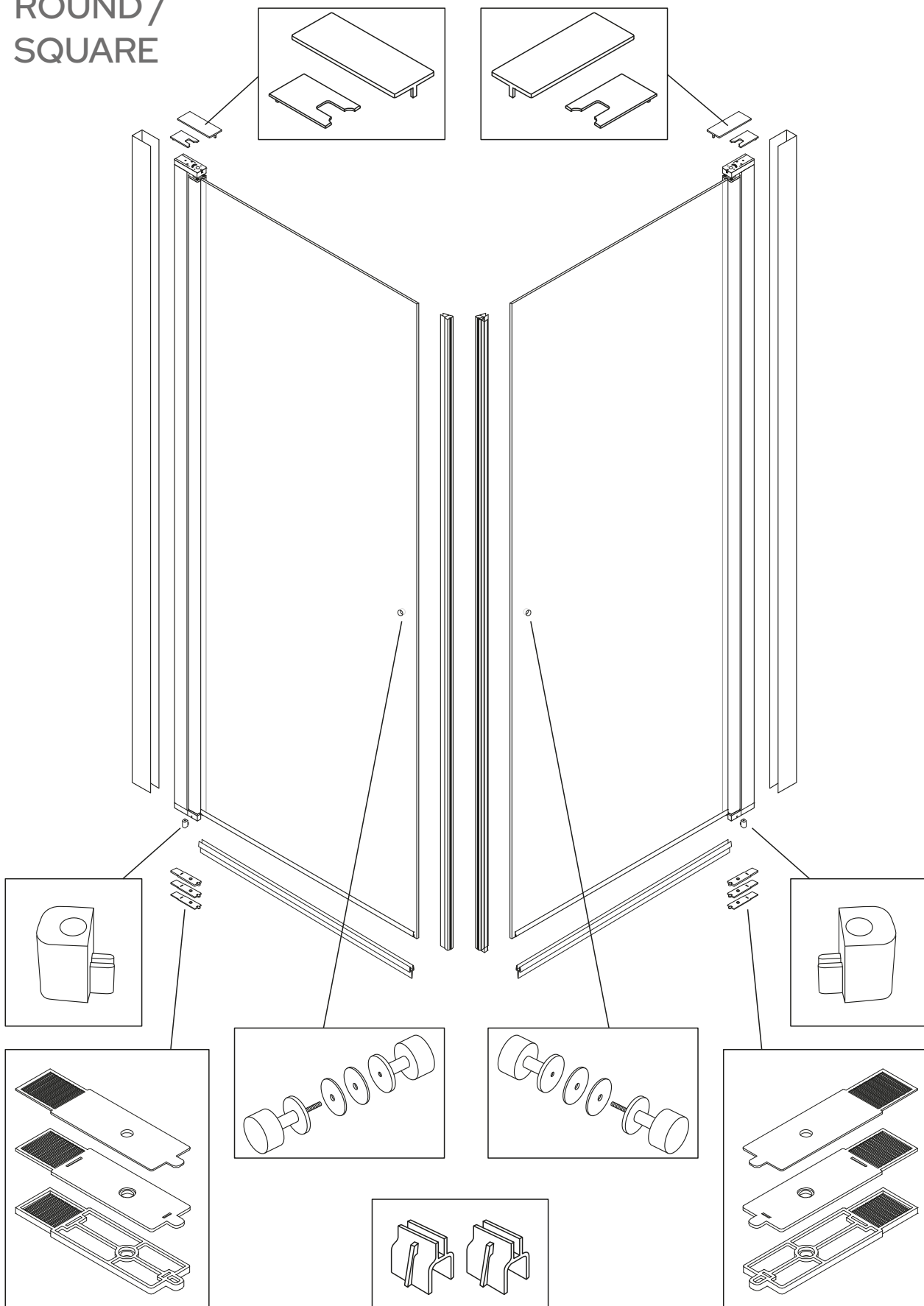





ROUND / SQUARE

1

	A:	B:
800 x 800	790-810	790-810
900 x 900	890-910	890-910
1000 x 1000	990-1010	990-1010
800 x 900	790-810	890-910
800 x 1000	790-810	990-1010
900 x 800	890-910	790-810
900 x 1000	890-910	990-1010
1000 x 800	990-1010	790-810
1000 x 900	990-1010	890-910

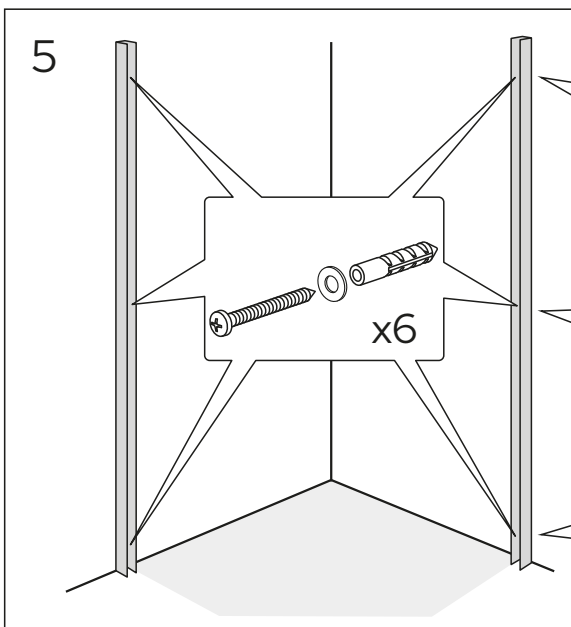
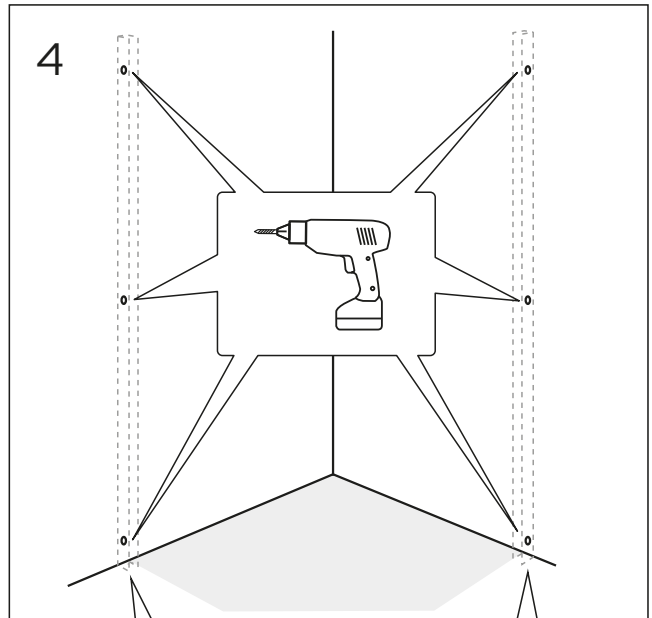
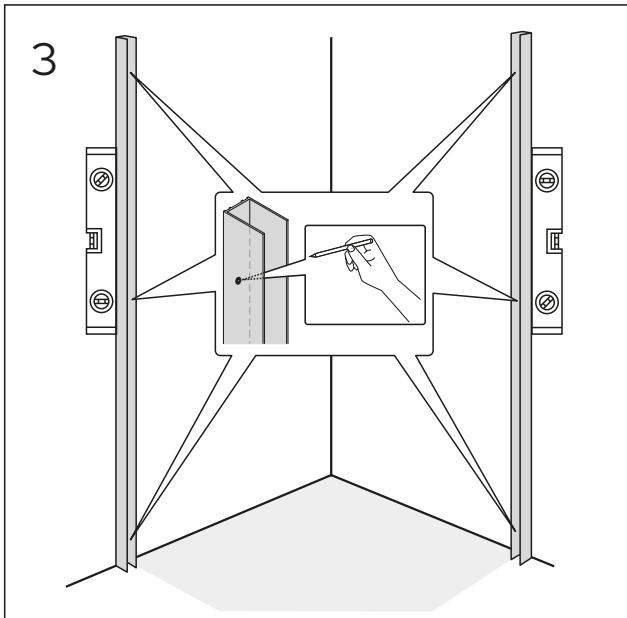
2





SE. Enligt Branschregler
Säker Vatteninstallation

Kraven på infästning och tätning gäller i våtzon. Alla skruvinfästningar ska göras i massiv konstruktion, t ex i betong, i regel eller särskild konstruktionsdetalj. Skruv- infästningar får inte göras enbart i golv- eller väggskiva.

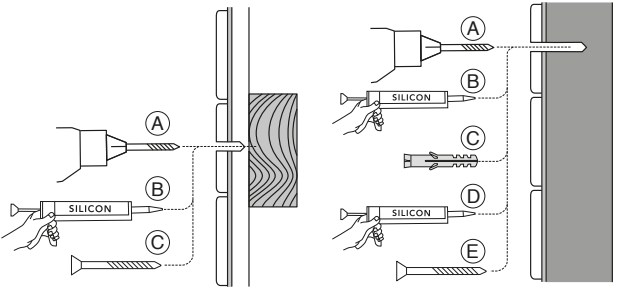

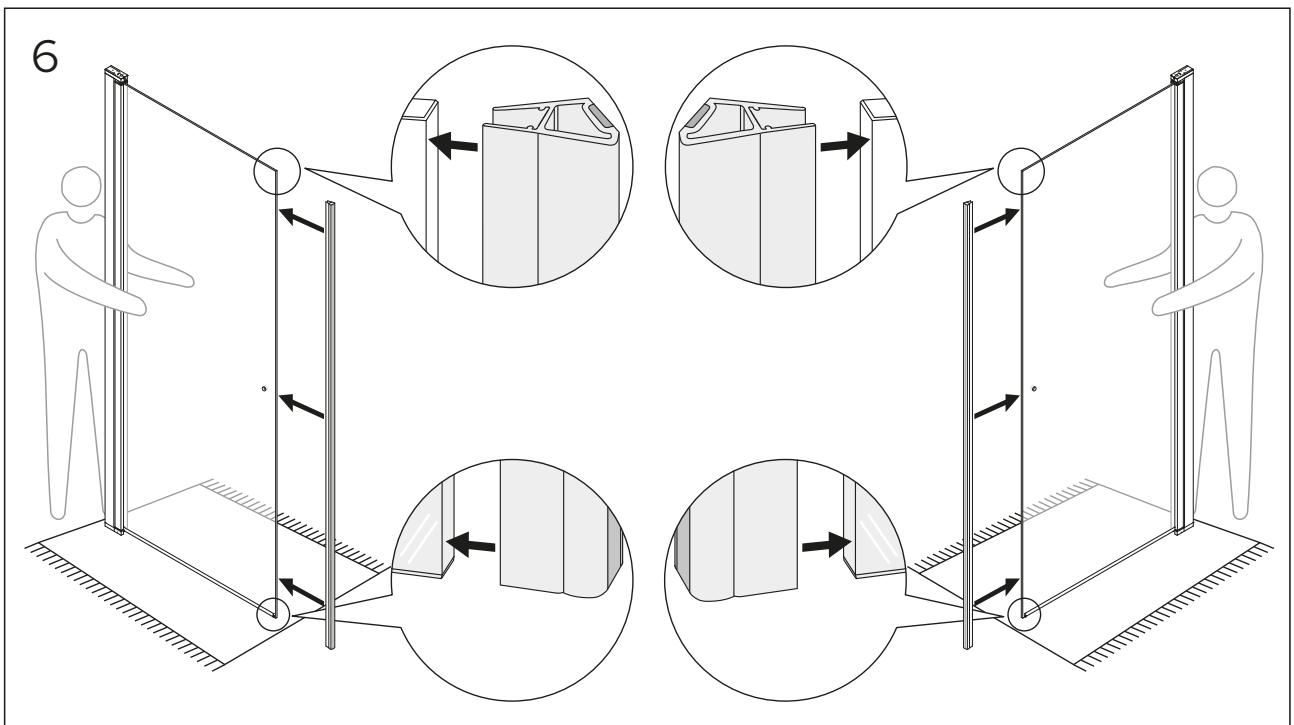

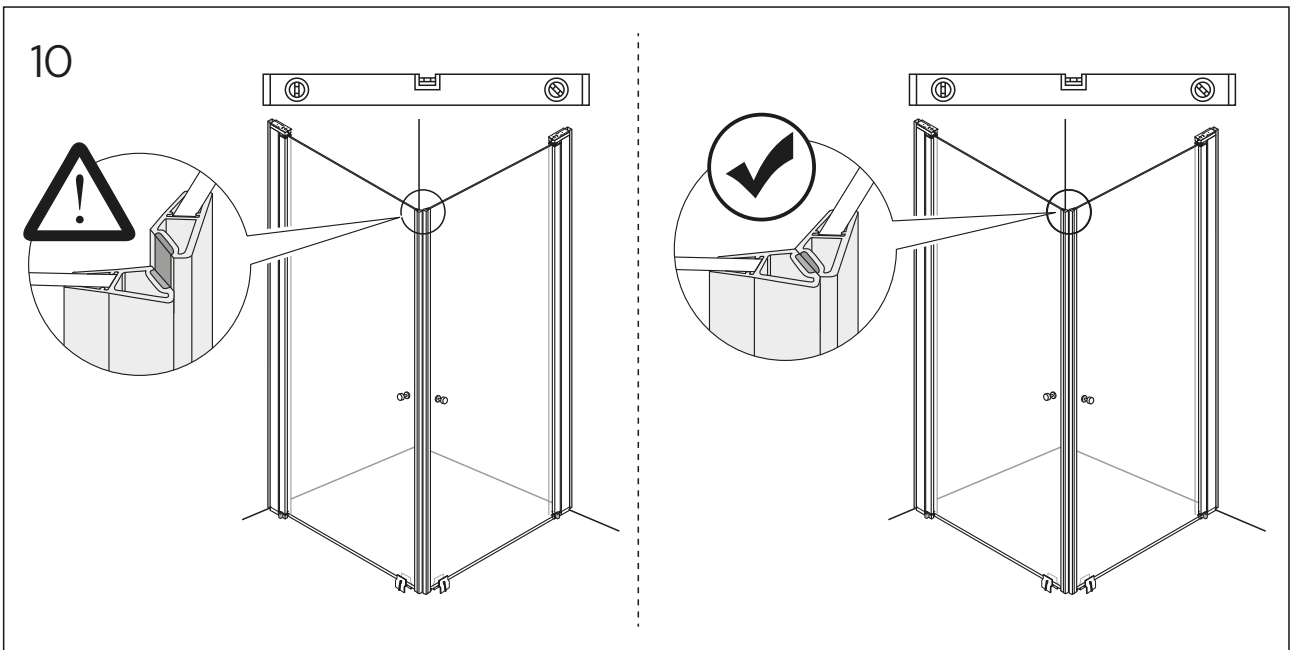
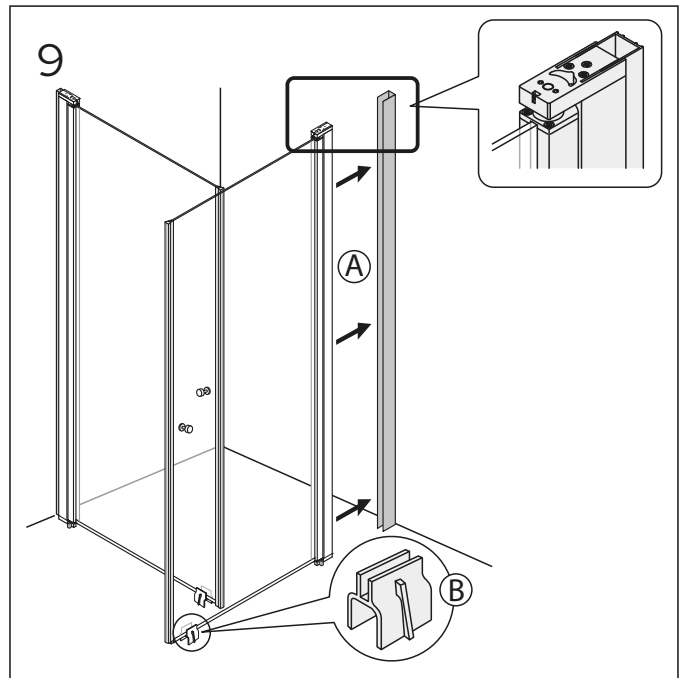
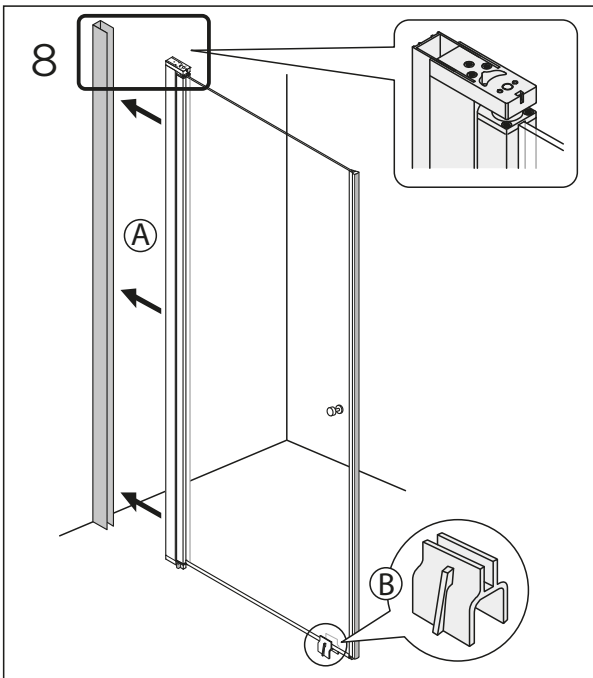
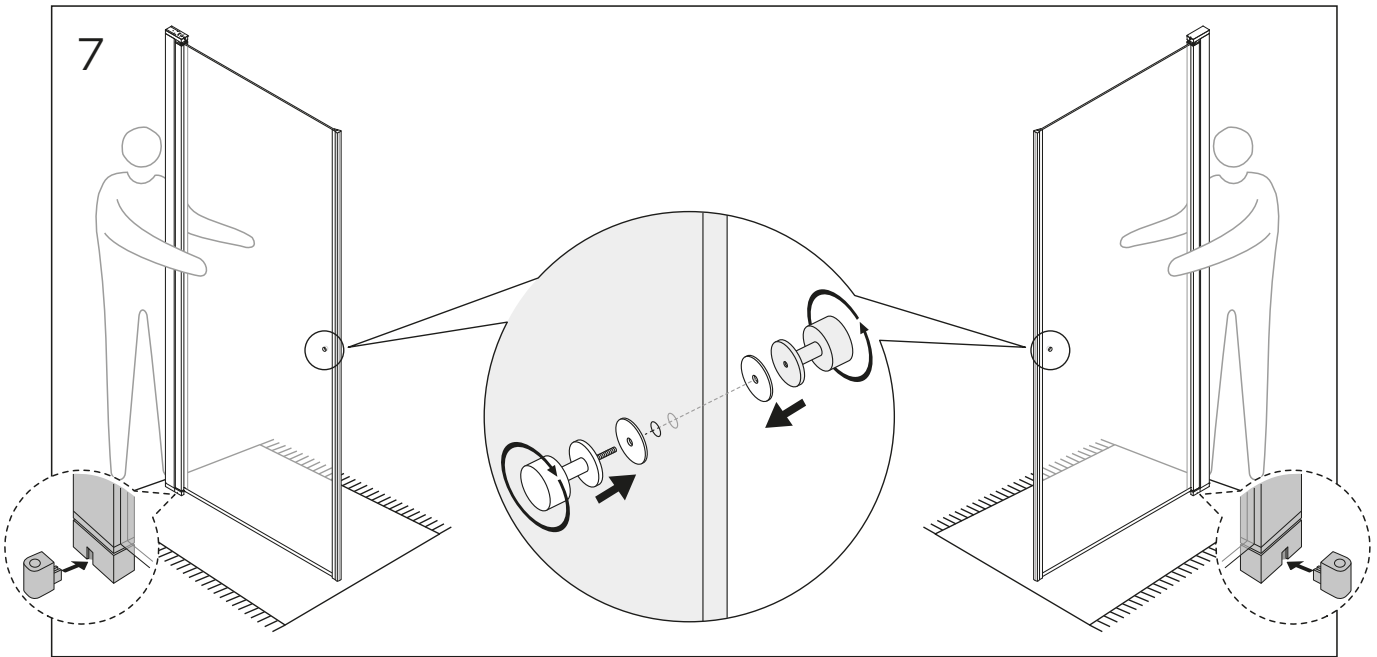

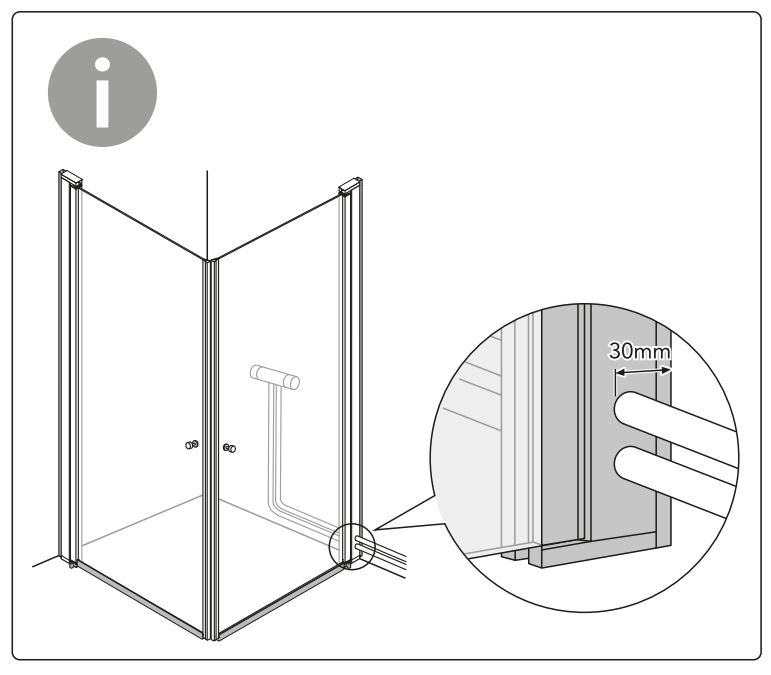
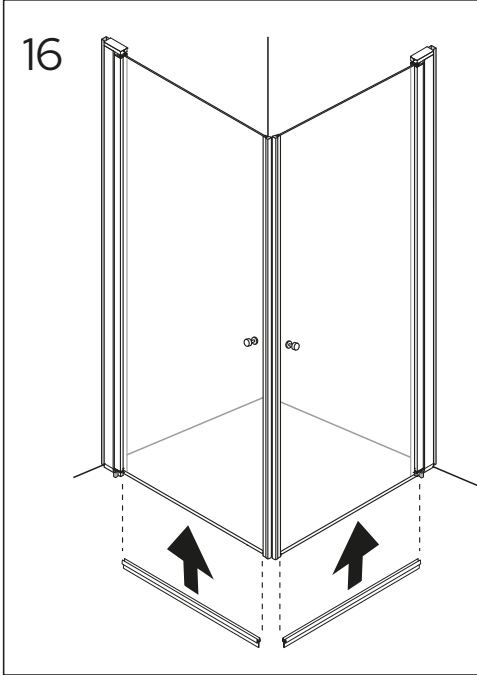
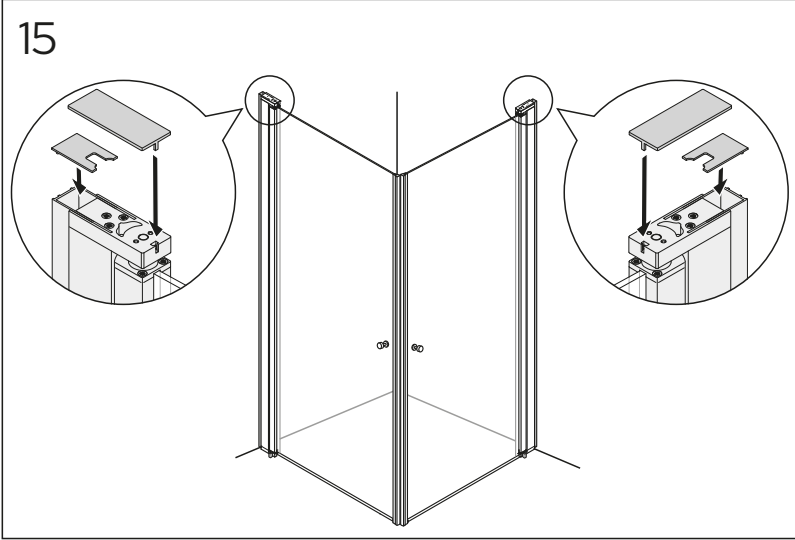
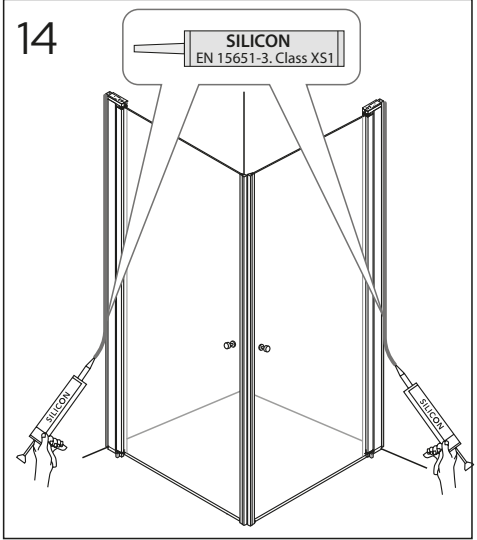
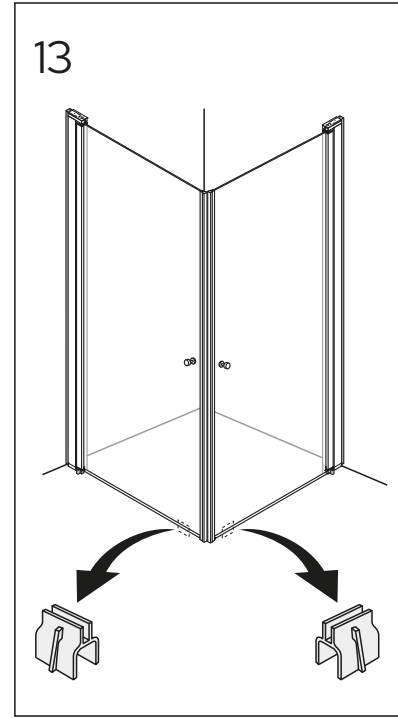
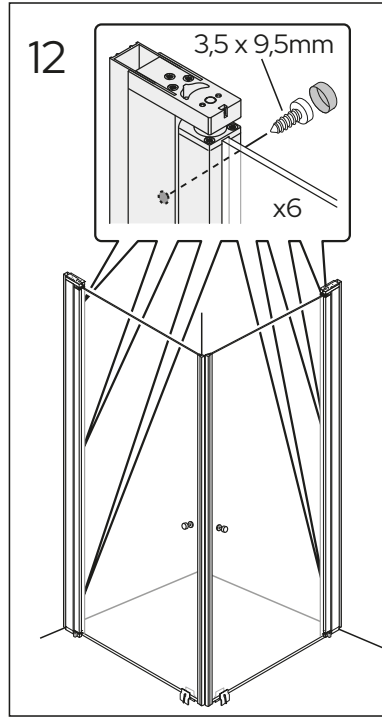
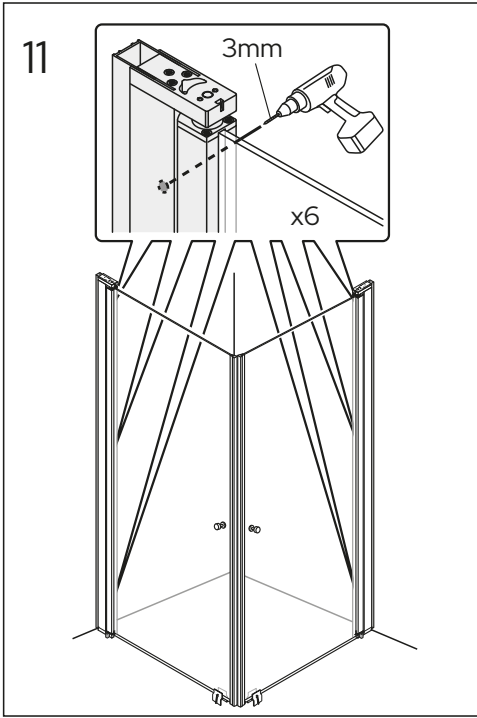



NICHE

1

	A:
800	796-826
900	896-926
1000	996-1026

2

3

4

! SE. Enligt Branschregler
Säker Vatteninstallation

Kraven på infästning och tätning gäller i våtzone. Alla skruvinfästningar ska göras i massiv konstruktion, t ex i betong, i regel eller särskild konstruktionsdetalj. Skruv- infästningar får inte göras enbart i golv- eller väggskiva.



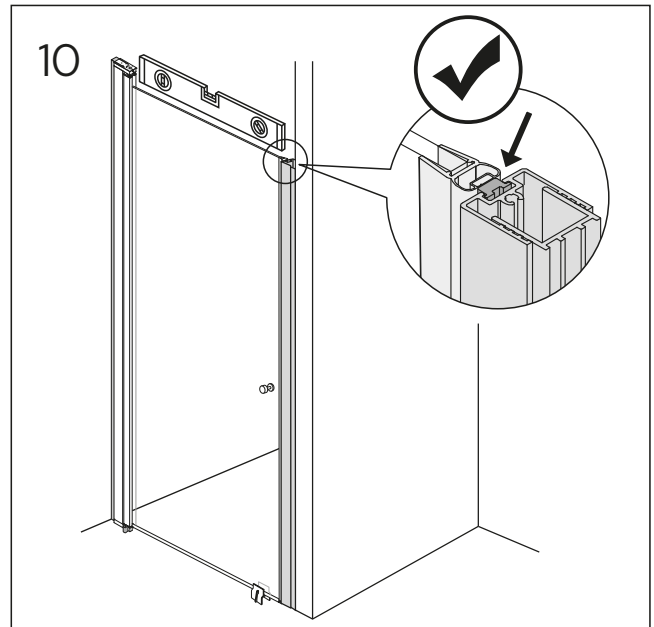
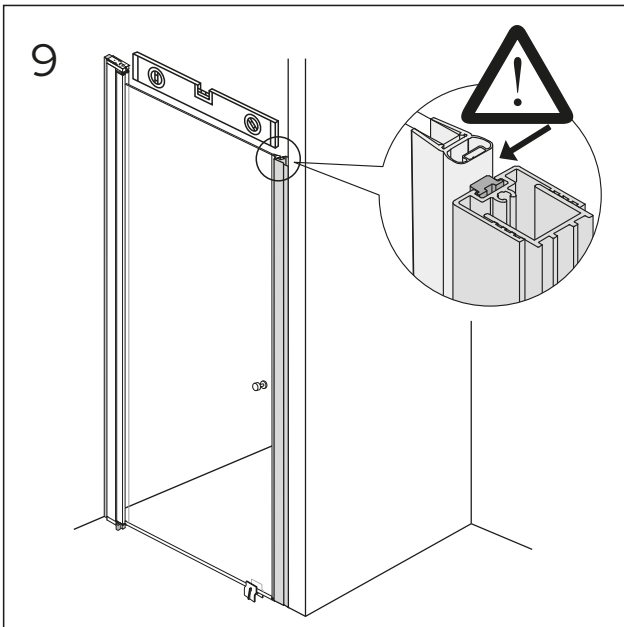
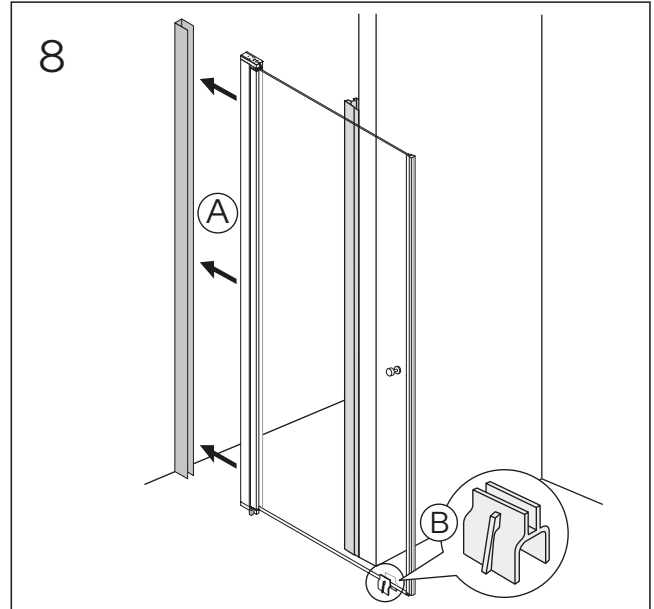
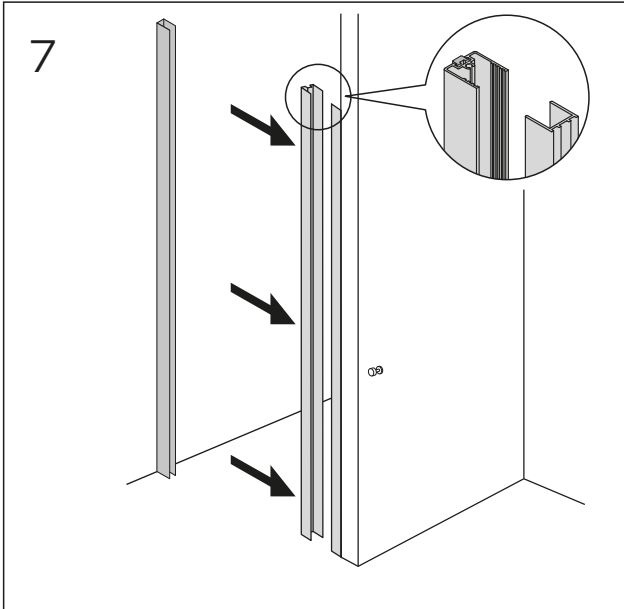
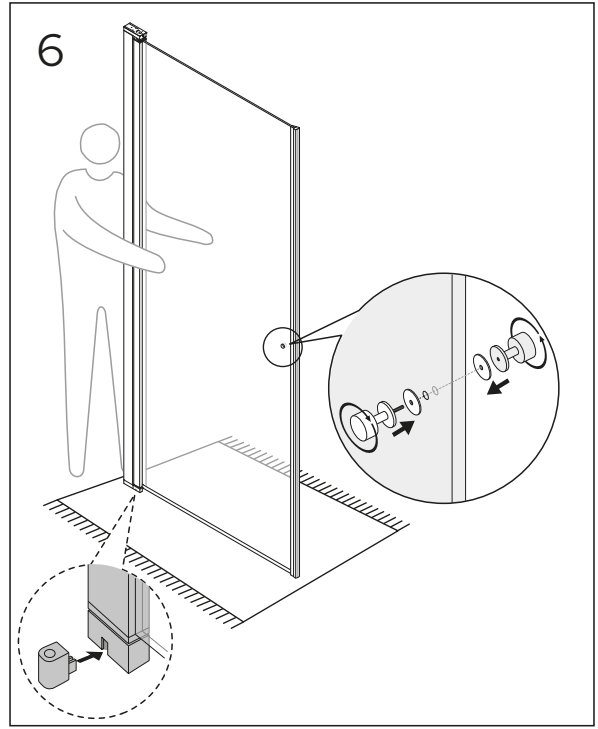
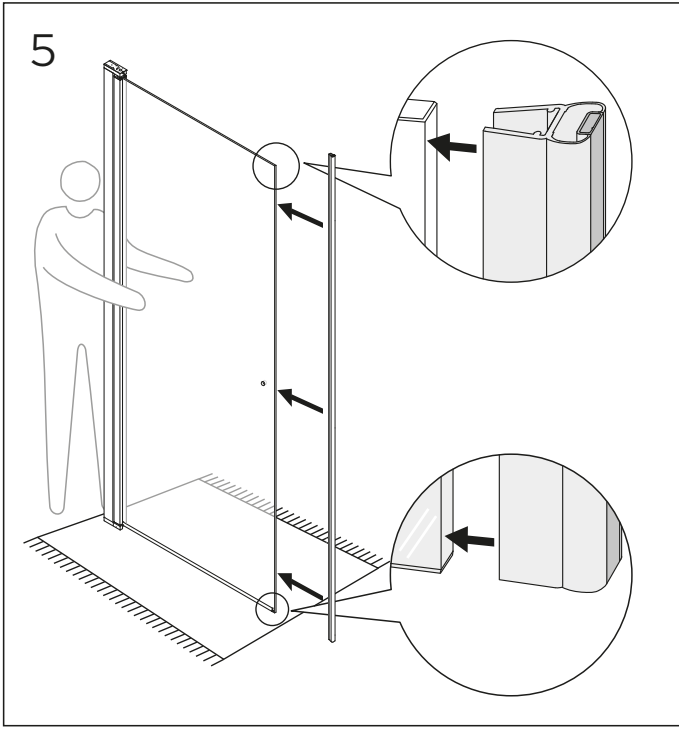

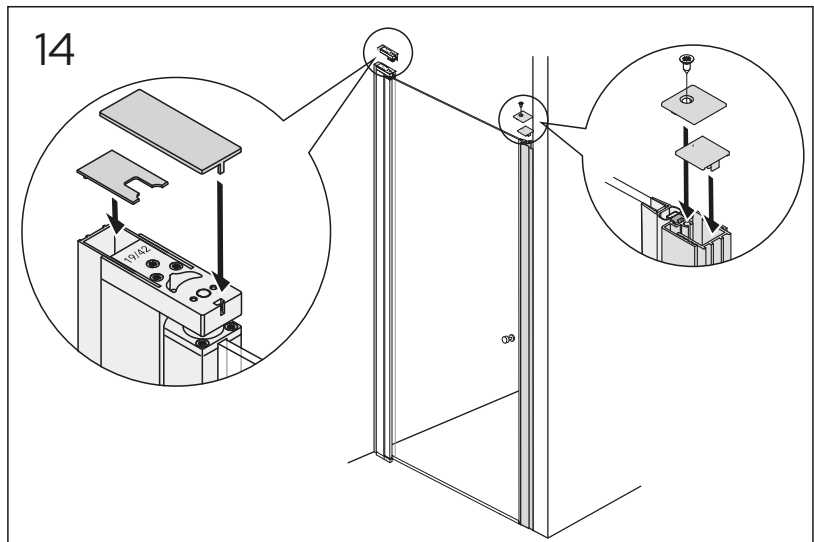
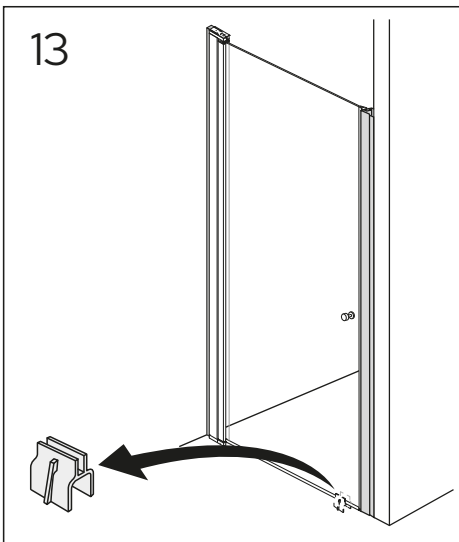
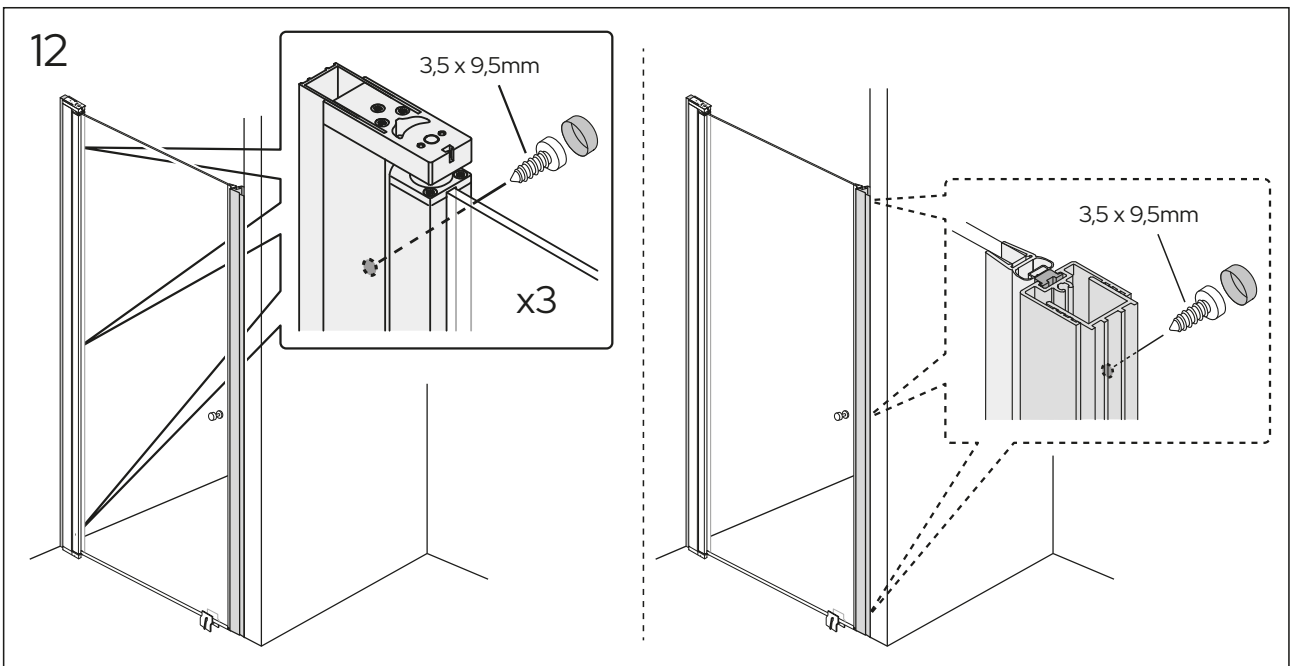
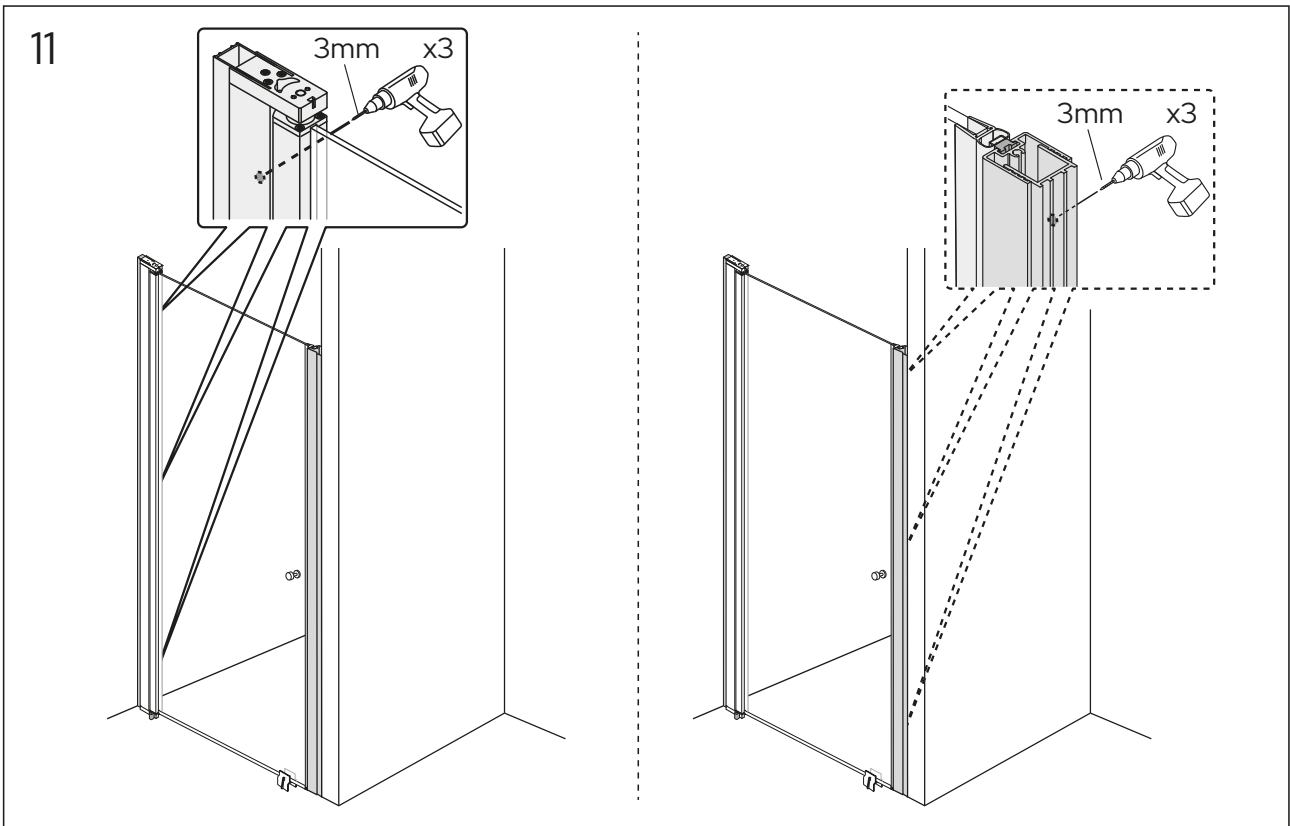

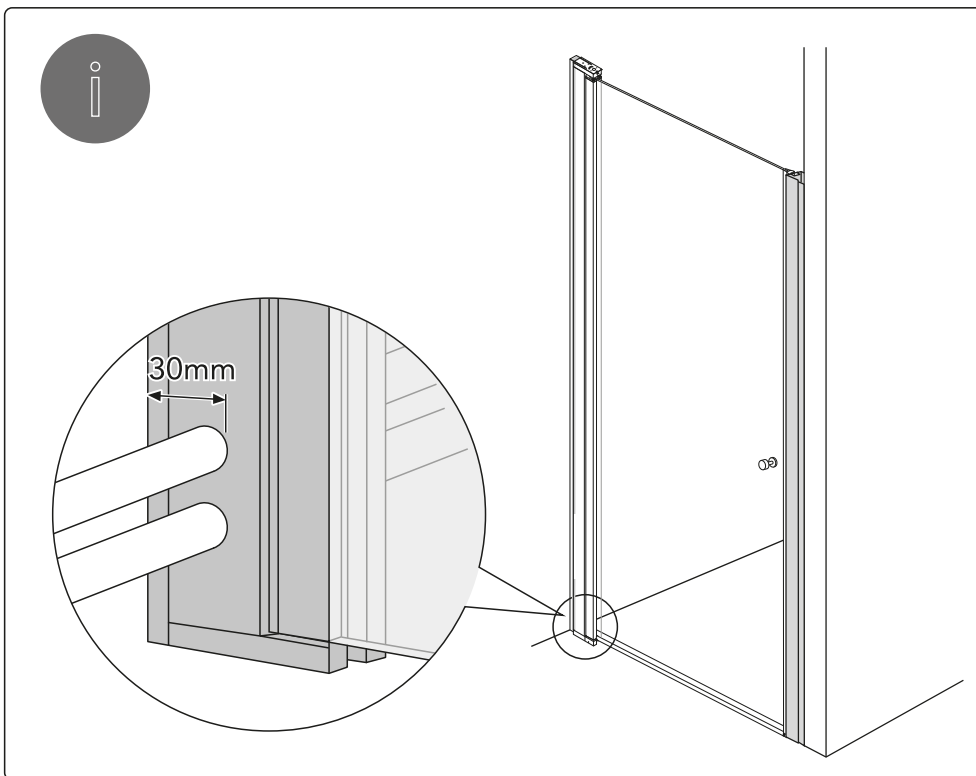
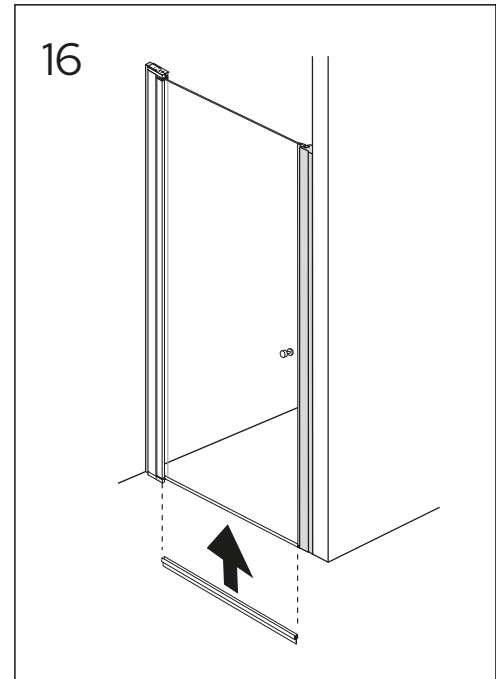
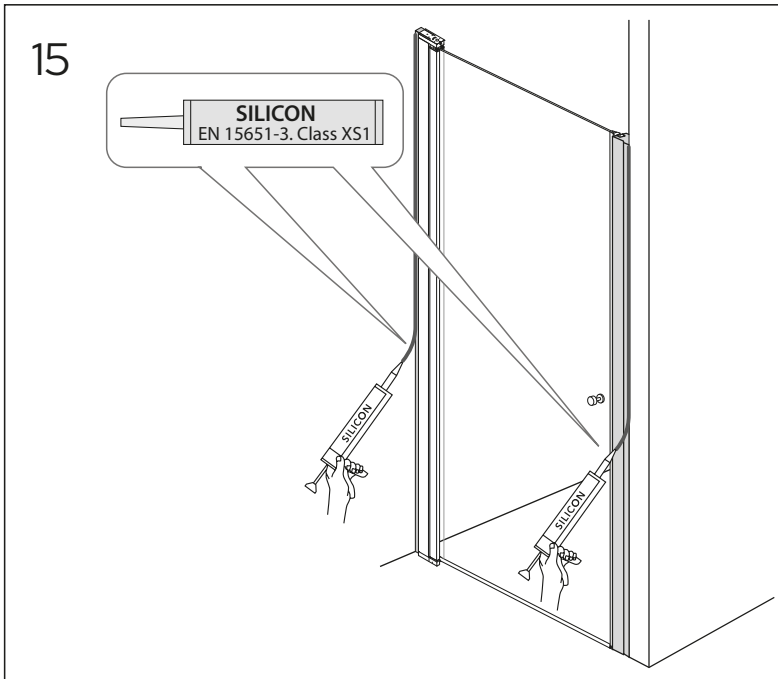



Reservdelar
 Reservedeler
 Reservedele
 Varaosat
 Spare parts
 Varuosad
 Atsarginės dalys
 Rezerves daļas



Drift & skötsel
 Drift og vedligeholdelse
 Drift og vedlikehold
 Asennus-, käyttö- ja hoito-ohjeet
 Assembly and maintenance
 Paigaldamine & hooldamine
 Montaza un kopsana
 Montavimas ir priežiūra

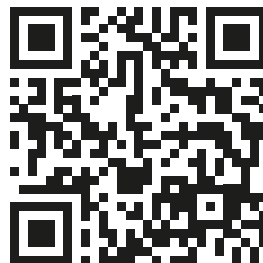

Sweden
 Gustavsberg AB
 Odelbergs väg 11
 134 46 Gustavsberg

Norway
 Gustavsberg AS
 Smeltingeløen 1
 0195 Oslo

Denmark
 Gustavsberg A/S
 Hobrovej 2
 2610 Rødovre

Finland
 Gustavsberg Oy
 Linnoitustie 6d
 02600 Espoo

Estonia
 Gustavsberg OY Esti Filialal
 F.R. Faehlmanni 6
 10125 Tallinn

Latvia
 Gustavsberg OY Latvijas Filiāle
 Roberta Hirsā ielā 1, office 303
 LV-1045 Rīga

Lituania
 Gustavsberg OY filialas
 Polocko 28B-1
 Vilnius, LT 01205

