

<b>EN</b>	Table of contents	<b>1</b>
	Instructions for use / assembly instructions	<b>2</b>
	Troubleshooting	<b>3</b>
	Dimensions	<b>6</b>
	Flow diagram	<b>6</b>
	Assembly	<b>7 - 11</b>
	Adjustment	<b>12</b>
	Safety Function	<b>13</b>
	Operation	<b>14 - 15</b>
	Maintenance	<b>16 - 17</b>
	Cleaning	<b>18 - 21</b>
	Spare parts	<b>22</b>
	Contact information	<b>24</b>
<b>SV</b>	Innehållsförteckning	<b>1</b>
	Bruksanvisning / Monteringsanvisning	<b>4</b>
	Felsökning	<b>5</b>
	Måttskiss	<b>6</b>
	Flödesschema	<b>6</b>
	Montering	<b>7 - 11</b>
	Inställning av maxtemperatur	<b>12</b>
	Safety Function	<b>13</b>
	Hantering	<b>14 - 15</b>
	Skötsel	<b>16 - 17</b>
	Rengöring	<b>18 - 21</b>
	Reservdelar	<b>22</b>
	Kontaktinformation	<b>24</b>

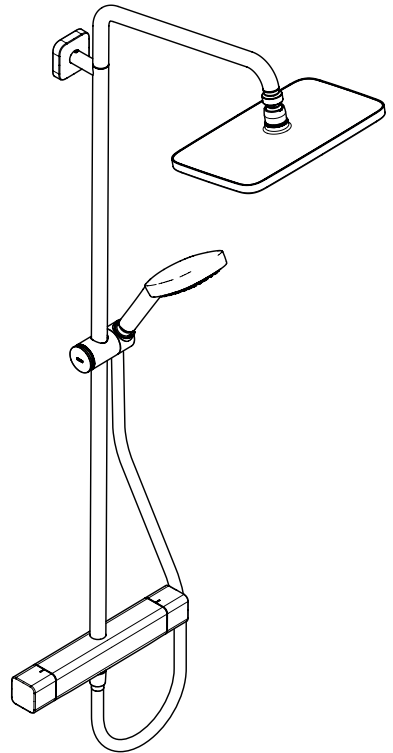

**Croma E**  
**Showerpipe 280 1jet 160cc**  
 26069000



## Safety Notes

- ⚠ Gloves should be worn during installation to prevent crushing and cutting injuries.
- ⚠ The arm of the shower head is intended only to hold the shower head. Do not load it down with other objects!
- ⚠ Children as well as adults with physical, mental and/or sensoric impairments must not use this shower system without proper supervision. Persons under the influence of alcohol or drugs are prohibited from using this shower system.
- ⚠ Do not allow the streams of the shower touch sensitive body parts (such as your eyes). An adequate distance must be kept between the shower and you.
- ⚠ The product may not be used as a holding handle. A separate handle must be installed.
- ⚠ The shower system may only be used for bathing, hygienic and body cleaning purposes.
- ⚠ The hot and cold supplies must be of equal pressures.

## Installation Instructions

- Prior to installation, inspect the product for transport damages. After it has been installed, no transport or surface damage will be honoured.
- The product is not designed to be used with steam baths!
- The pipes and the fixture must be installed, flushed and tested as per the applicable standards.
- The plumbing codes applicable in the respective countries must be observed.
- The installation dimensions stated in these installation instructions are ideal for people of approximately 1800 mm in body height. The dimensions can be altered if required. In this case, pay attention to the fact that a change of installation height will also change the minimum height, and that the altered mounting dimensions must be taken into consideration.
- Where the contractor mounts the product, he should ensure that the entire area of the wall to which the mounting plate is to be fitted, is flat (no projecting joints or tiles sticking out), that the structure of the wall is suitable for the installation of the product and has no weak points. The enclosed screws and dowels are only suitable for concrete. For another wall constructions the manufacturer's indications of the dowel manufacturer have to be taken into account.

- The filter insert must be use to protect the shower against incoming dirt by pipework. Incoming dirt leads to defects or/and can damage parts of the shower; such caused faults voids all liability and guarantee claims.
- If required, the bottom part of the pipe between the fixture and the shower head can be shortened with a fine-toothed saw.

## Assembly (see page 7)

## Pressure and permeability test

The connections of the thermostatic mixer should be tested regular after installation.

## Technical Data

Operating pressure:	max. 1 MPa
Recommended operating pressure:	0,15 - 0,5 MPa
Test pressure:	1,6 MPa
(1 MPa = 10 bar = 147 PSI)	
Hot water temperature:	max. 70 °C
Recommended hot water temp.:	65 °C
Centre distance:	160 mm
Connections M 26x1,5:	cold right - hot left
Thermal disinfection:	max. 70 °C / 4 min

- Safety against backflow
- The product is exclusively designed for drinking water!



## Symbol description



Do not use silicone containing acetic acid!



## Adjustment (see page 12)

After the installation, the output temperature of the fitting must be tested and set to the temperate desired by the customer. Correction is necessary if the temperature measured at the take off point differs from the temperature set on the scale.

## max. $\approx 42^{\circ}\text{C}$ Safety Function (see page 13)

The desired maximum temperature for example max.  $42^{\circ}\text{C}$  can be pre-set thanks to the safety function.



## Dimensions (see page 6)



## Flow diagram (see page 6)

- ① Hand shower
- ② Overhead shower



## Spare parts (see page 22)

## Special accessories (order as an extra)



#93527000 tile matching disk chrome plated (see page 22)



## Maintenance (see page 16)

- The check valves must be checked regularly according to DIN EN 1717 in accordance with national or regional regulations (at least once a year)
- To guarantee the smooth running of the thermostat, it is necessary from time to time to turn the thermostat from total hot to total cold.



## Cleaning (see page 18)



## Operation (see page 14)

To empty the overhead shower after use, hold it in a slightly inclined position.

## Troubleshooting

Fault	Cause	Remedy
Insufficient water	- Supply pressure inadequate	- Check water pressure (If a pump has been installed check to see if the pump is working).
	- Filters are dirty (97367000)	- Cleaning the filter in the water connection and at the thermostat cartridge (97367000)
	- Shower filter seal dirty	- Clean filter seal between shower and hose
Crossflow, hot water being forced into cold water pipe, or vice versa, when mixer is closed	- Backflow preventers dirty or leaking	- Clean backflow preventers, exchange if necessary
Spout temperature does not correspond with temperature set	- Thermostat has not been adjusted	- Adjust thermostat
	- Hot water temperature too low	- Increase hot water temperature to $42^{\circ}\text{C}$ to $65^{\circ}\text{C}$
Temperature regulation not possible	- thermo cartridge calcified	- Exchange thermo cartridge
Instantaneous heater didn't work with thermostat	- Filters are dirty	- Clean the filter / exchange filter
	- check valve hasn't moved back	- Exchange check valves





## Säkerhetsanvisningar

- △ Handskar ska bäras under monteringsarbetet så att man kan undvika kläm- och skärskadorgen werden.
- △ Armen som håller huvudduschen är bara konstruerad för detta; den får inte belastas med andra föremål!
- △ Barn samt vuxna med fysiska, psykiska eller sensoriska funktionshinder får inte använda duschsystemet ensamma. Personer som är påverkade av alkohol- eller droger får inte använda duschsystemet.
- △ Undvik att rika duschstrålarna mot känsliga kroppsdelar (t. ex. ögonen). Det måste finnas ett tillräckligt stort avstånd mellan duschen och kroppen.
- △ Produkten får inte användas som handtag. Ett separat handtag måste monteras.
- △ Duschsystemet får bara användas till kroppshygien med bad och dusch.
- △ Stora tryckskillnader mellan anslutningarna för varmt och kallt vatten måste utjämnas.

## Monteringsanvisningar

- Det måste undersökas om produkten har transport-skador innan den monteras. Efter monteringen accepteras inga transport- eller ytskiktsskador.
- Produkten är inte avsedd att användas tillsammans med ett ångbad!
- Ledningarna och blandaren måste monteras, spolats igenom och kontrolleras enligt de gällande normerna.
- De installationsriktlinjer som gäller i länderna ska följas.
- De monteringsmått som anges i monteringsanvisningen passar 1,80 m långa personer och måste eventuellt anpassas. Det är då viktigt att tänka på att den minsta höjden ändras när monteringshöjden blir en annan och att hänsyn måste tas till de ändrade anslutningsmått.
- När kvalificerad fackpersonal monterar produkten är det viktigt att tänka på att monteringsytan är plan i alla delar av arbetsytan (inga fogar som sticker ut eller klinkerförskjutningar), att väggkonstruktionen passar till montering av produkten samt att den inte har svaga punkter. Medföljande skruvar och plugg är endast avsedda för betong. Vid andra väggkonstruktioner skall anvisningarna från pluggtillverkaren beaktas.

- Silpackningen som följer med duschen måste monteras för att undvika att smuts från ledningsnätet tränger in. Smuts som spolats in kan påverka funktionerna och/eller leda till skador på funktionsdelar i duschen. Hansgrohe fransäger sig allt ansvar för skador som kan härledas till detta.
- Om det behövs kan röret mellan blandare och huvuddusch kortas i den nedre delen med en fintandad såg.

## Montering (se sidan 7)

### Tryck och täthetsprov

Termostatblandarens anslutningar skall täthetkontrolleras efter installationen.

### Tekniska data

Driftstryck:	max. 1 MPa
Rek. driftstryck:	0,15 - 0,5 MPa
Tryck vid provtryckning: (1 MPa = 10 bar = 147 PSI)	1,6 MPa
Varmvattentemperatur:	max. 70 °C
Rek. varmvattentemp.:	65 °C
Anslutningsmått:	160 mm
Anslutningar M 26x1,5:	kallt höger - varmt vänster
Termisk desinfektion:	max. 70 °C / 4 min

- Självspärr mot återflöde
- Produkten är enbart avsedd för dricksvatten!





## Symbolförklaring



Använd inte silikon som innehåller ättiksyra!

### Inställning av maxtemperatur (se sidan 12)

Efter monteringen måste blandarens uttemperatur kontrolleras och ställas in på den temperatur som kunden vill ha. En korrigering krävs när den uppmätta temperaturen vid tappstället avviker från den temperatur som är inställd på termostaten.

### max. $\approx 42^{\circ}\text{C}$ Safety Function (se sidan 13)

Med hjälp av Safety Function kan du ställa in den önskade maximaltemperaturen till exempelvis  $42^{\circ}\text{C}$  och så förhindra skällningsrisk för barn.



### Måttén (se sidan 6)

### Flödesschema (se sidan 6)

- ① Handdusch
- ② Huvuddusch



### Reservdelar (se sidan 22)

### Specialtillbehör (medföljer ej leveransen)

#93527000 Kakelutjämningsbricka krom



### Skötsel (se sidan 16)

- Backventilens funktion måste kontrolleras regelbundet enligt nationella eller regionala bestämmelser (en gång per år) i enlighet med DIN EN 1717.
- För att garantera att termostaten ej kalkar igen, ska den regelbundet, en gång per vecka, konditioneras. Det sker genom att man några gånger snabbt slår om temperaturen från hett till kallt och tillbaka.



### Rengöring (se sidan 18)



### Hantering (se sidan 14)

Ställ huvudduschen lätt lutande efter användningen för att tömma den.

## Felsökning

### Störning

### Orsak

### Åtgärd

För lite vatten

- Vattentrycket är för lågt
- Smutsfiltren är igensmutsade (97367000)
- Silfiltret i duschen smutsigt

- Kontrollera ledningstryck
- Rengör smutsfilter i anslutningarna och på styrenheten (97367000)
- Rengör silfiltret mellan slangen och termostaten

Korsflöde – varmt vatten pressas vid avstängd ermostat in i kallvatten- inloppet, och vice versa

- Backventil är igensmutsad eller otät

- Rengör backventil, byt ut om nödvändigt

Den faktiska vatten-temperaturen stämmer inte överens med den inställda

- Termostaten ställdes inte in

- Justera termostaten

- Varmvattentemperaturen är för låg

- Höj varmvattentemperaturen till mellan  $42^{\circ}\text{C}$  och  $65^{\circ}\text{C}$

Temperaturen kan ej ställas in

- Termosensorn är igenkalkad

- Byt termosensorn

Varmvattenberedare slår ej på vid användning av termostaten

- Smutsfiltren är igensmutsade
- Backventil är defekt

- Rengör / byt smutsfilter
- Byt backventil



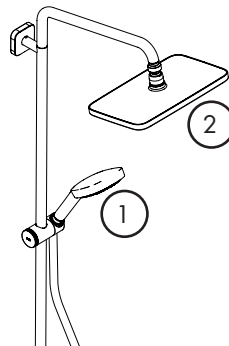
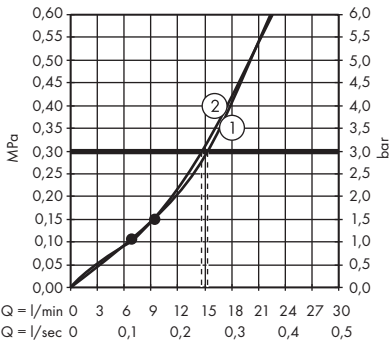
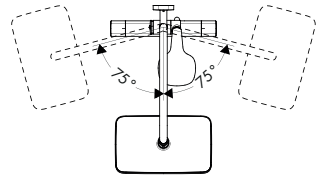
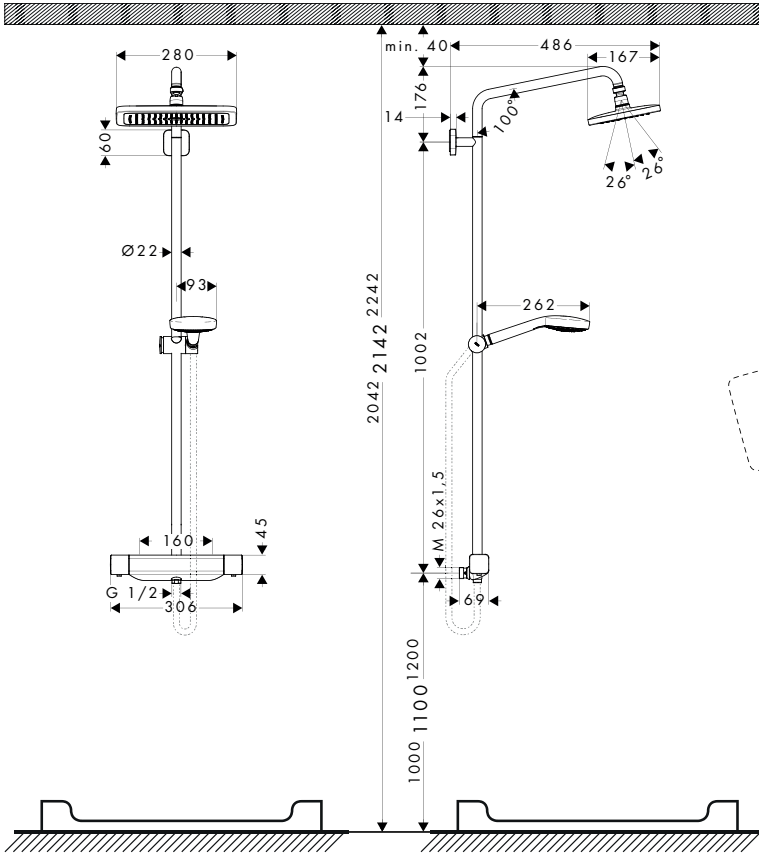

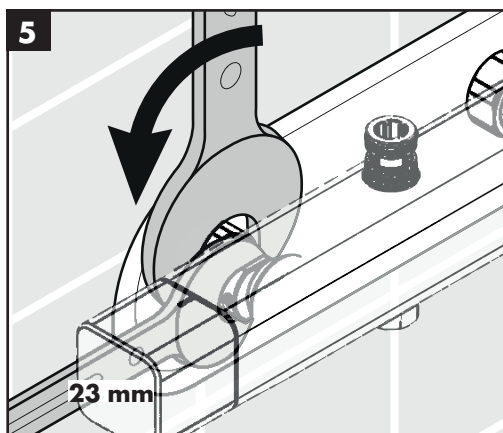
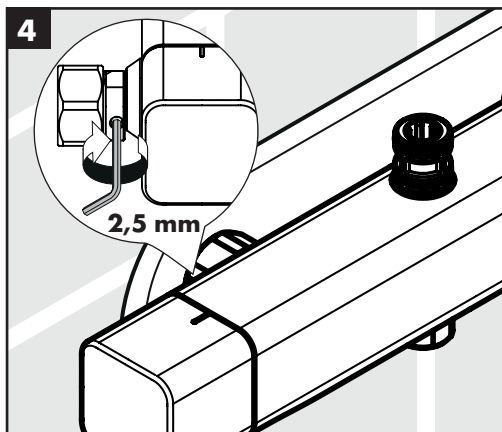
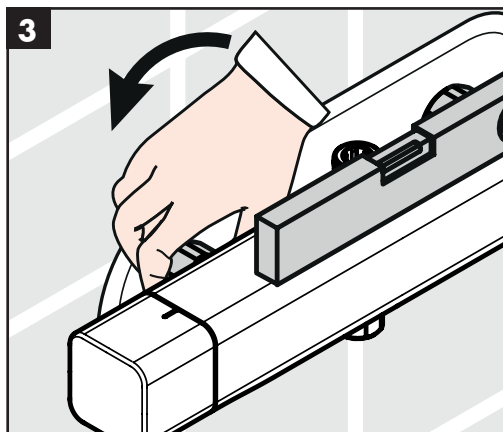
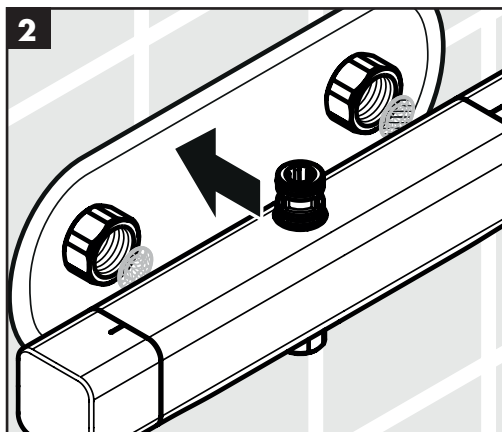
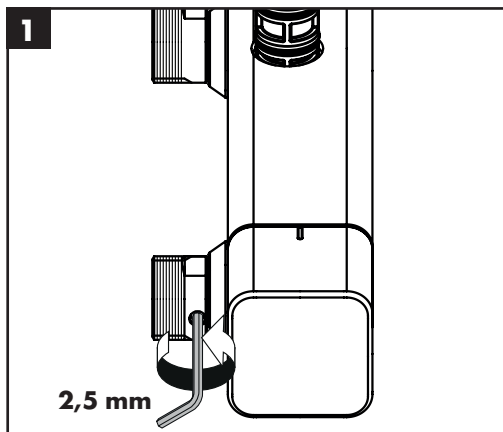

The nuts of the installation plate must be tightened to the manufacturer's instructions.

Muttrarna dras åt enligt monteringsanvisningen från leverantören av blandarfäste.

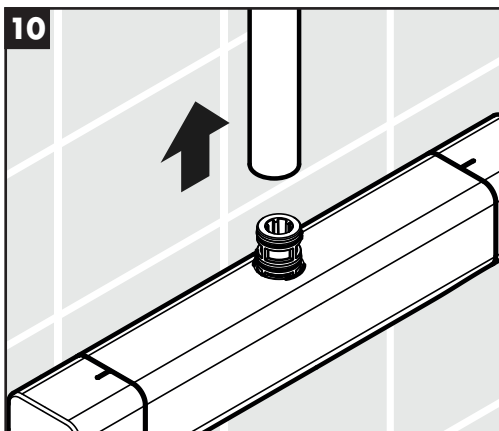
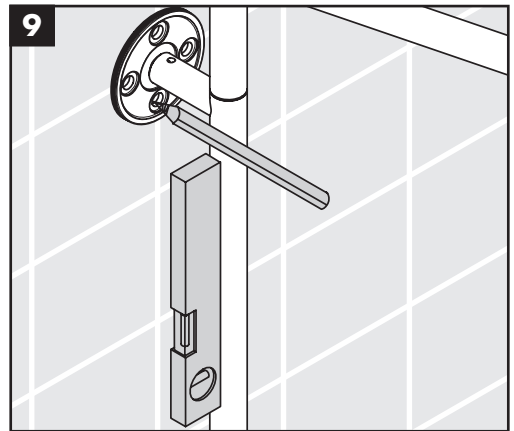
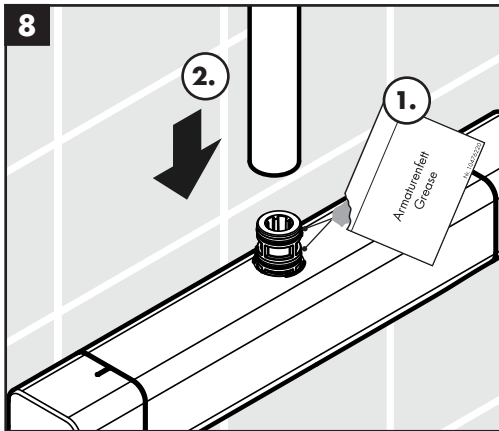
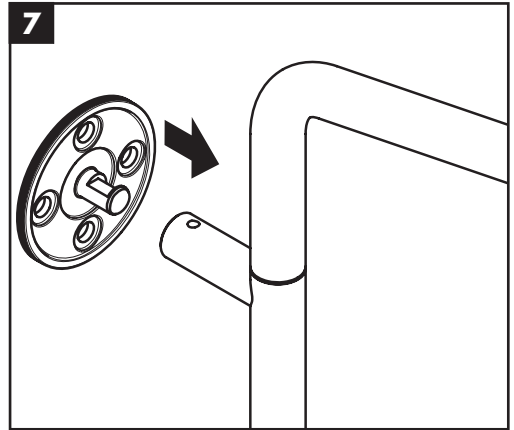
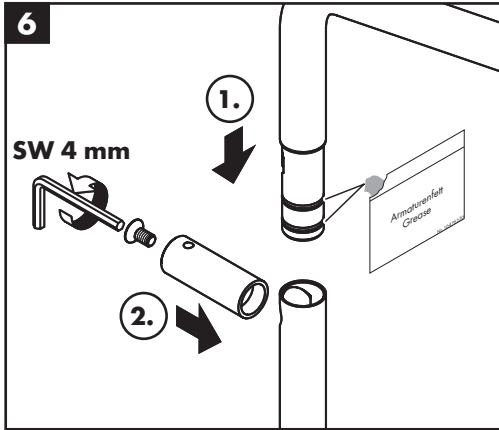

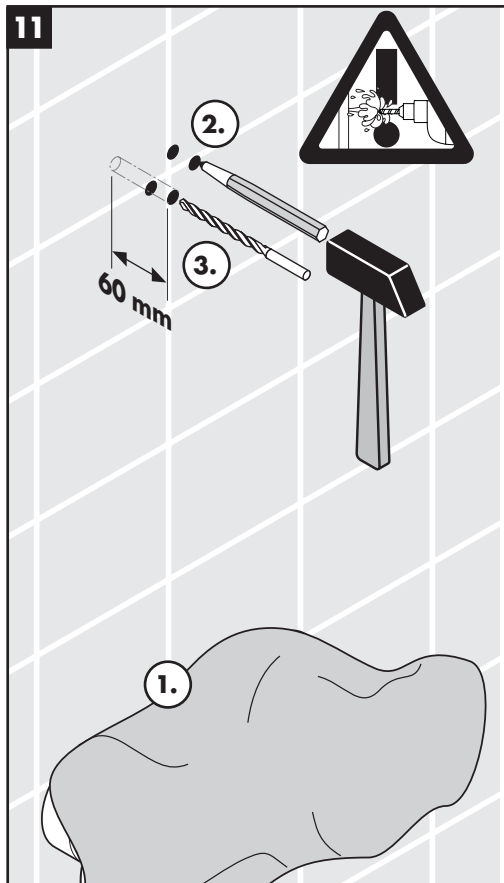

When installing on a stud wall, the wall must always be strengthened. All screws must be fixed to solid structures, such as concrete, studs or special structural components. Screws must not be fixed to flooring or wall sheets alone. Requirements for sealing apply in wet zones 1 and 2. Sealing materials must be fixed to the underlying layer and must be waterproof, mould-resistant and age-resistant.

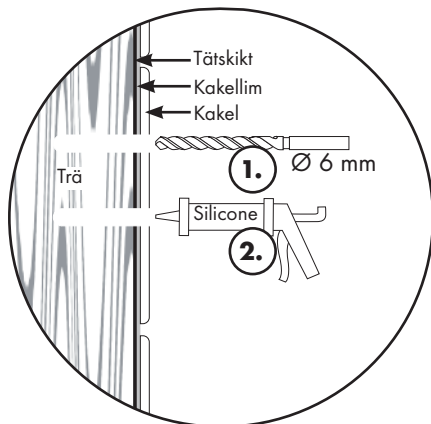
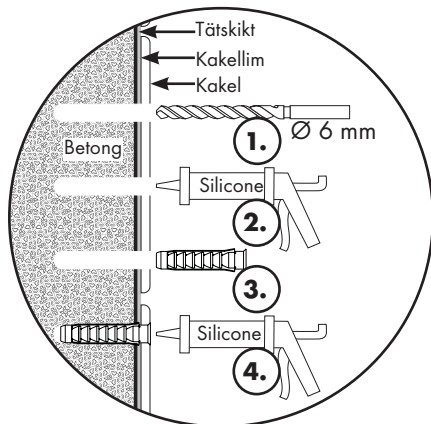

Vid montering på regelvägg måste väggen alltid förstärkas. Alla skruvinfästningar skall ske i massiv konstruktion, t.ex betong, i regler eller särskild konstruktionsdetalj. Skruvinfästning får inte göras enbart i golv-, eller väggskiva. Krav på tätning gäller både i våtzone 1 och 2. Material för tätning ska fästa mot underlaget och vara vattenbeständigt, mögelresistent och åldersbeständigt.

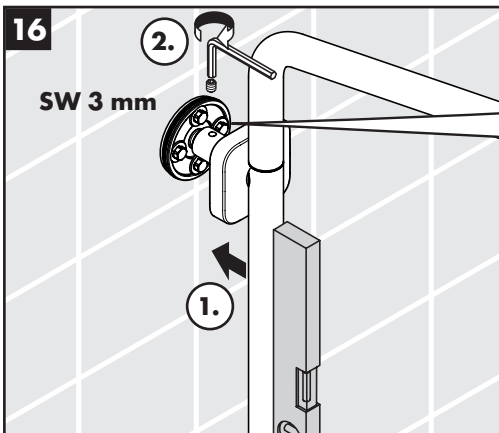
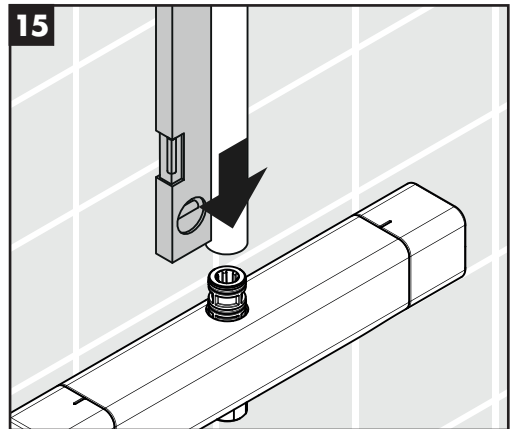
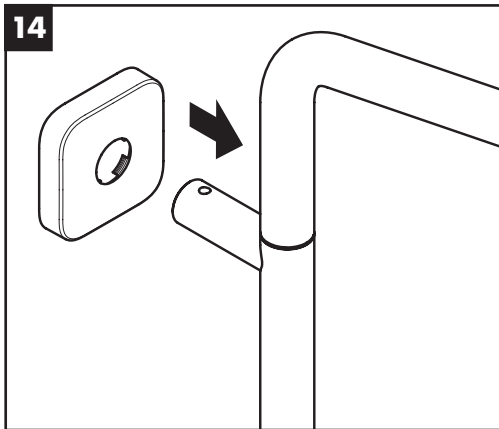
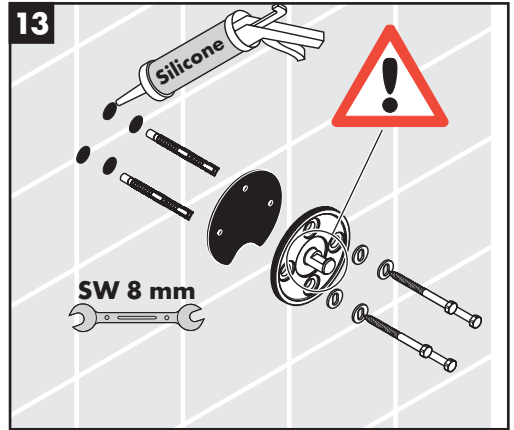
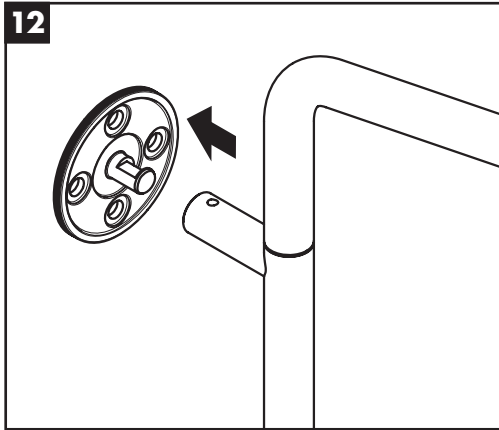

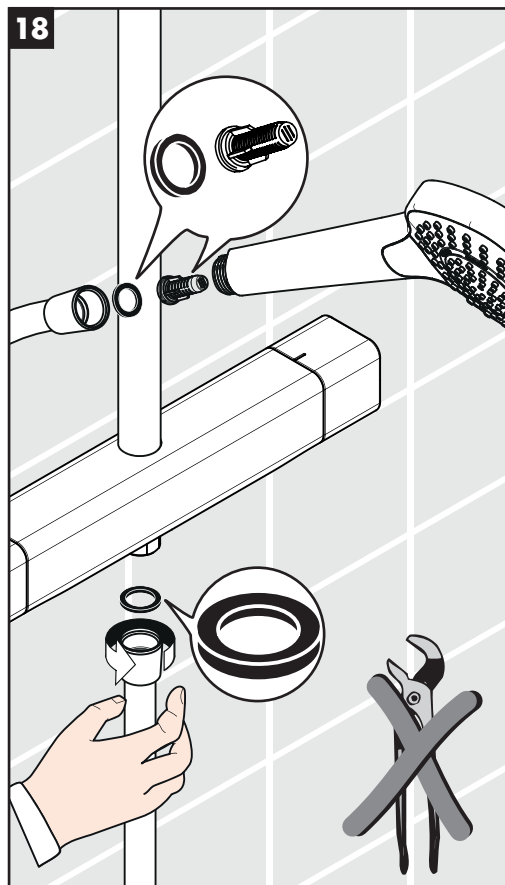
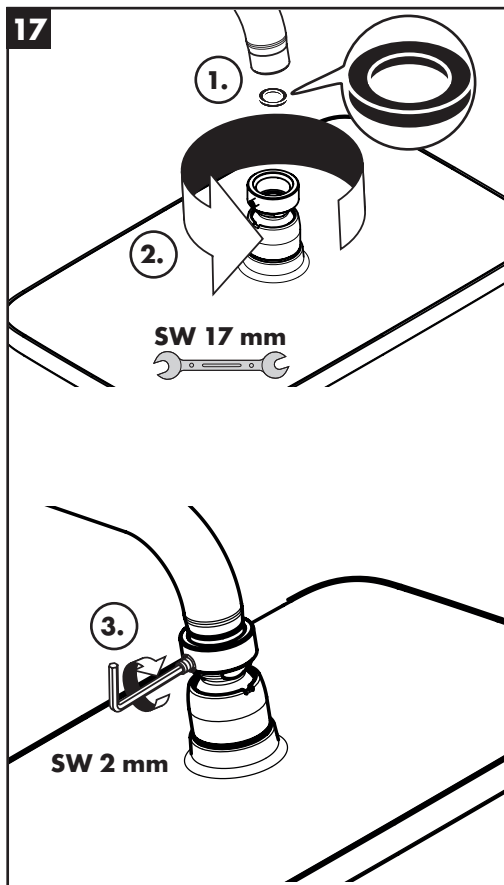

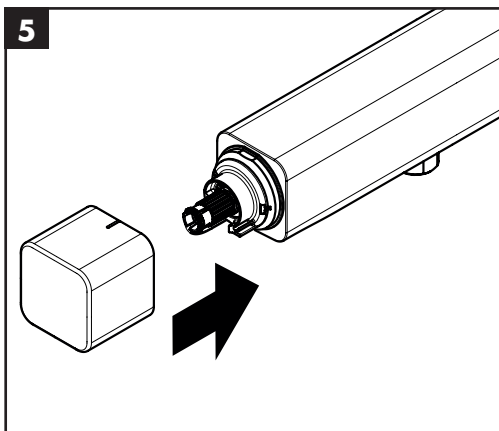
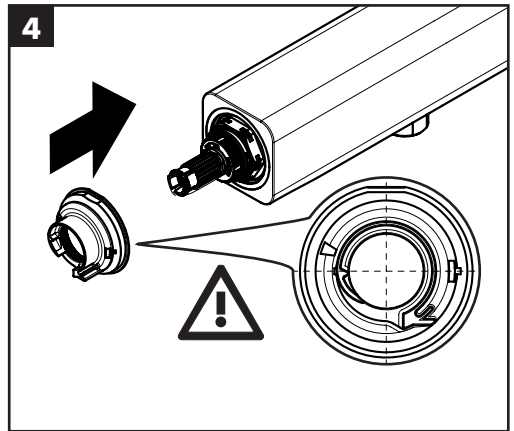
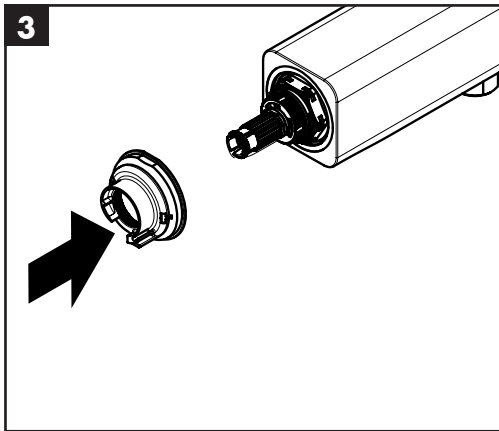
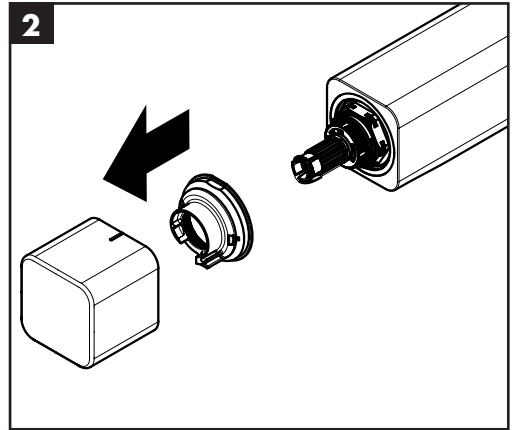
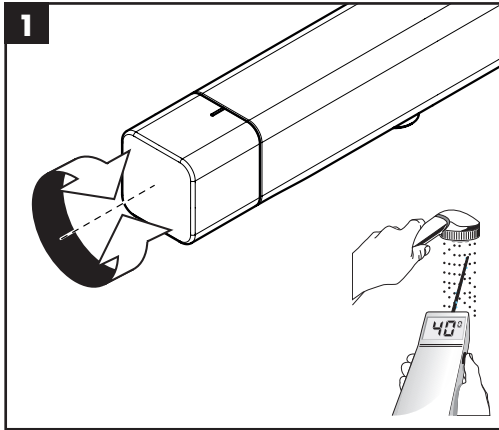



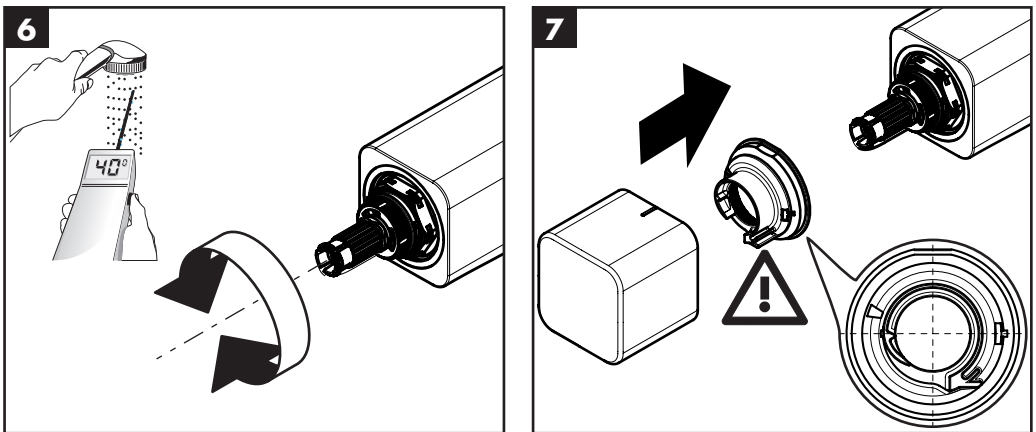
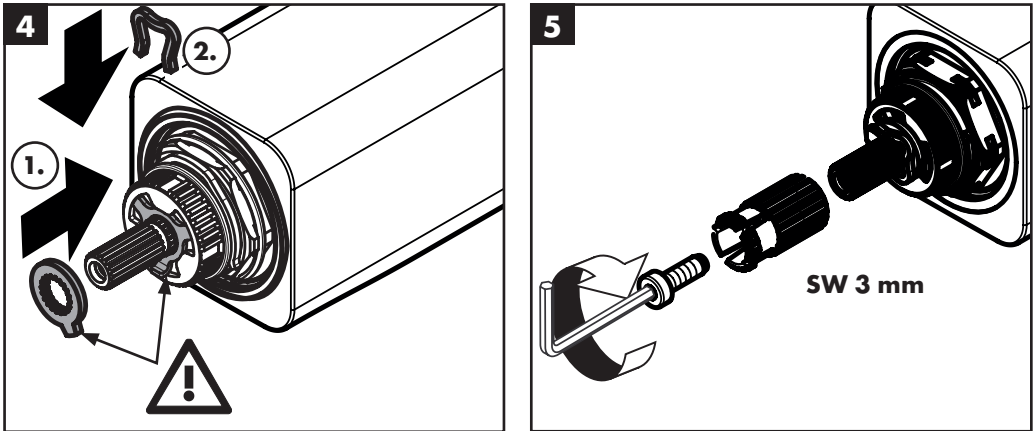
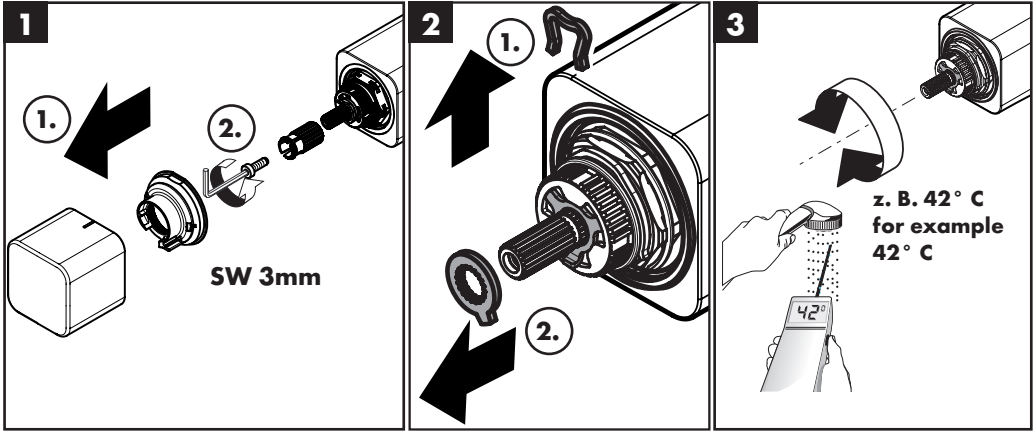

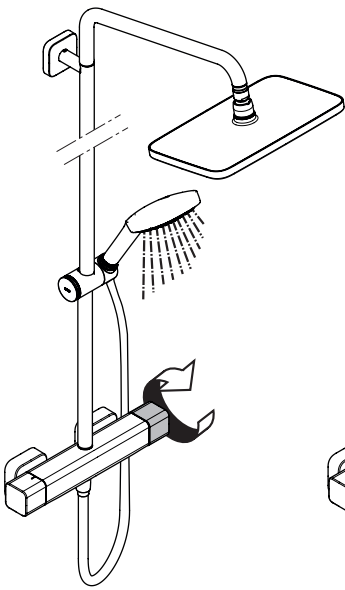

open / öppna

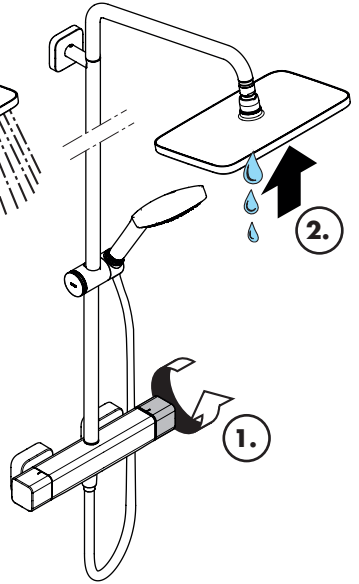
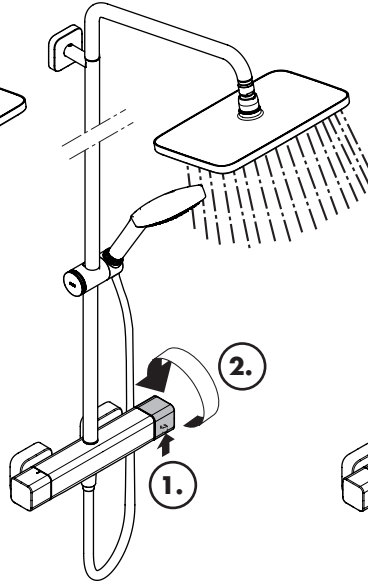

close / stänga

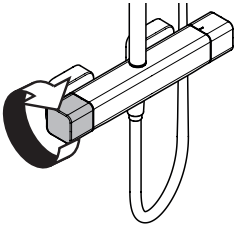

cold / kallt

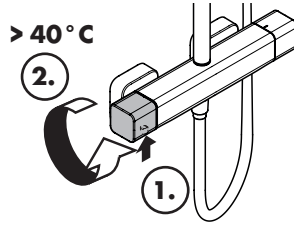

hot / varmt



## Croma Select E Multi

26810400



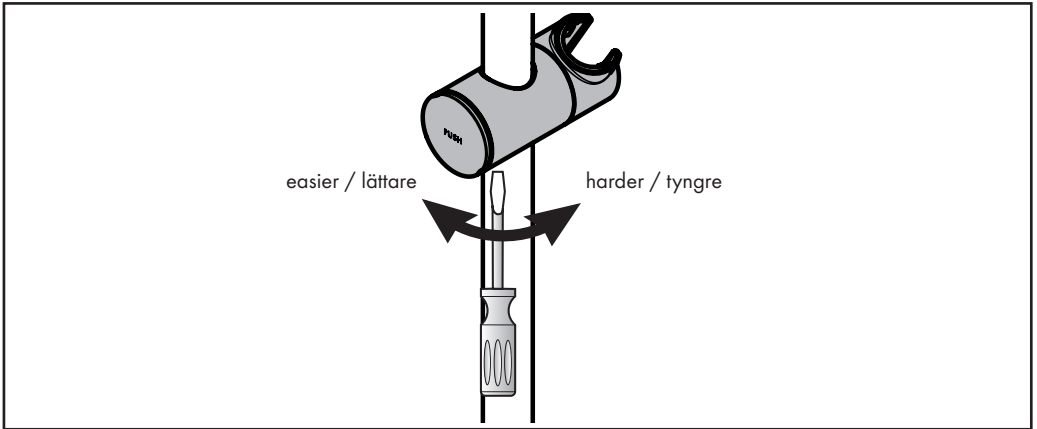
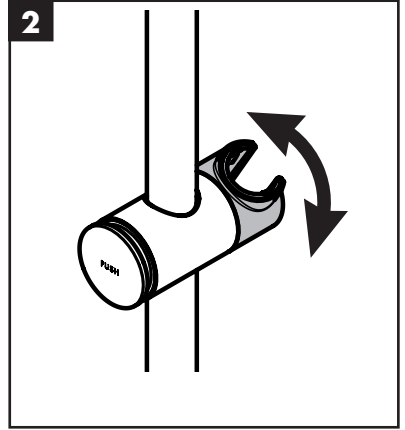
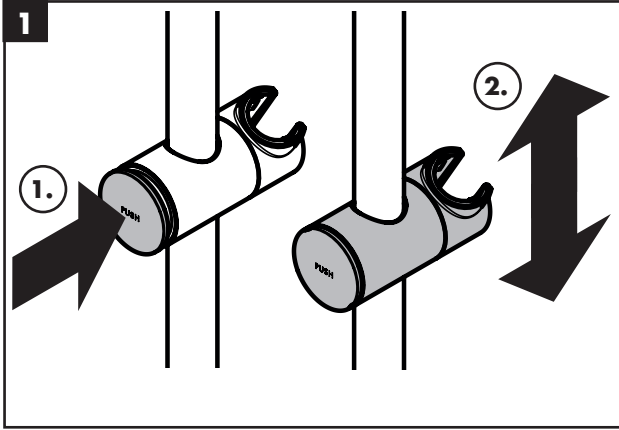

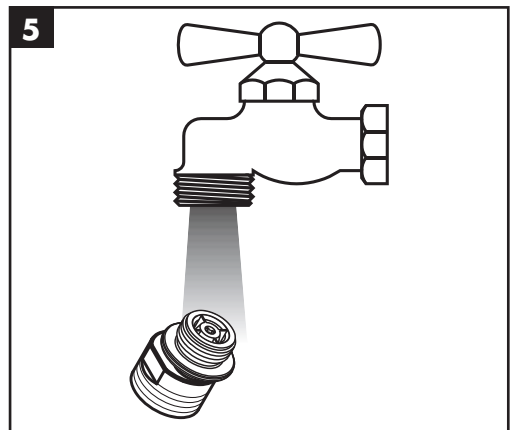
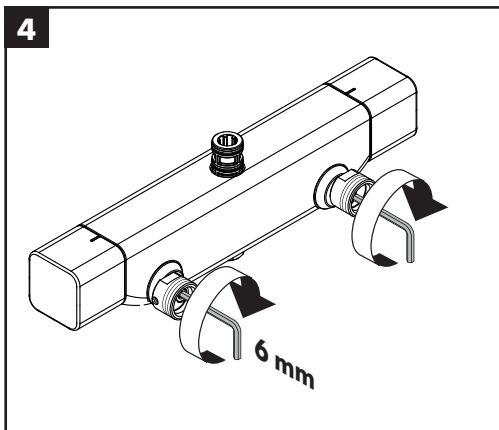
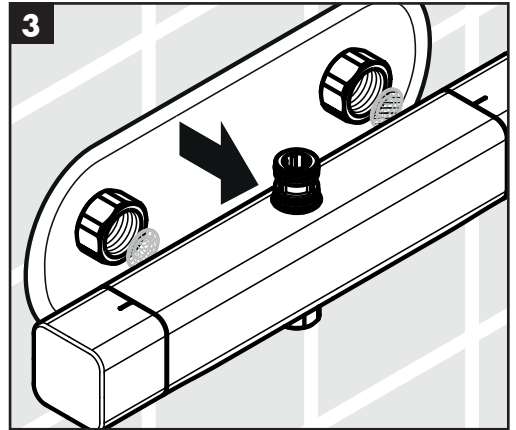
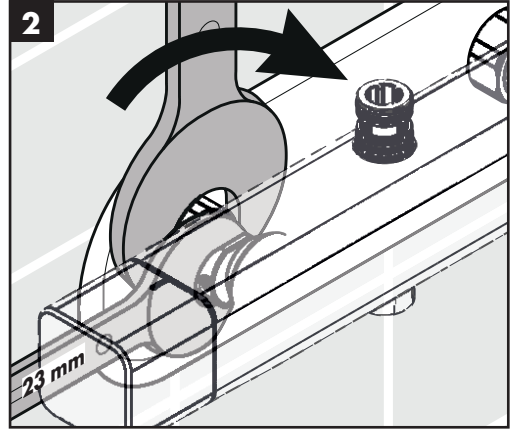
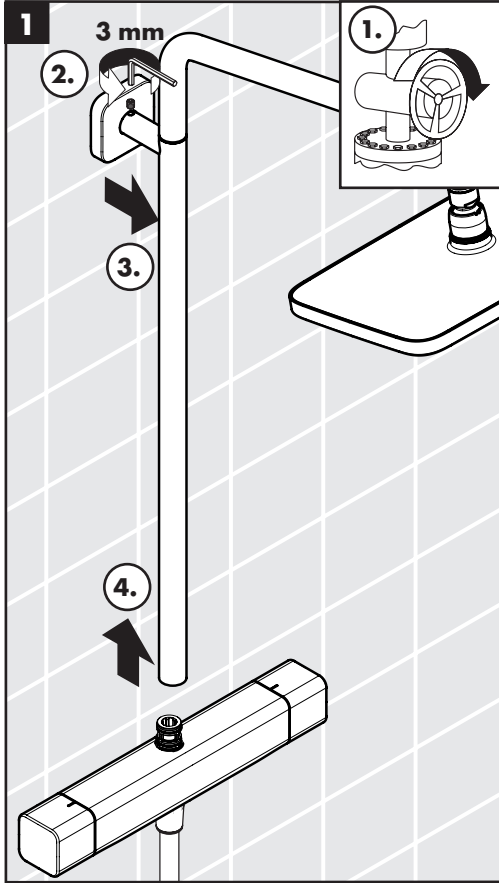

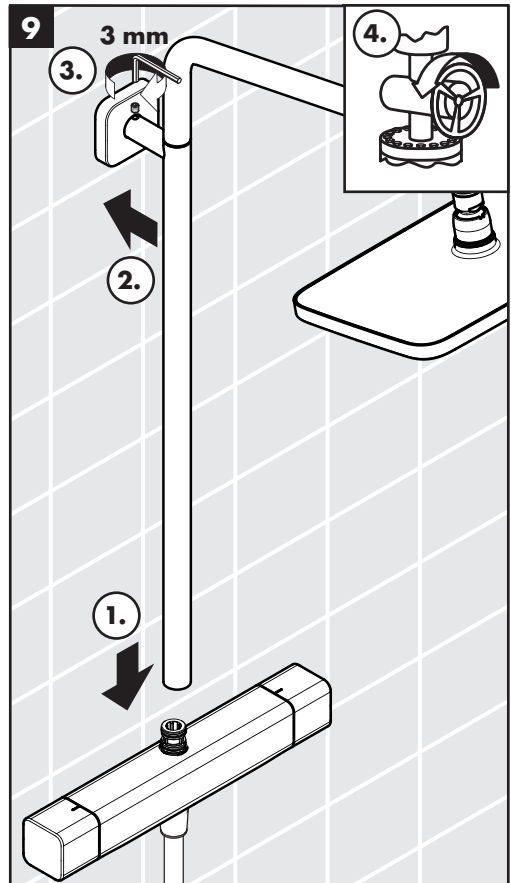
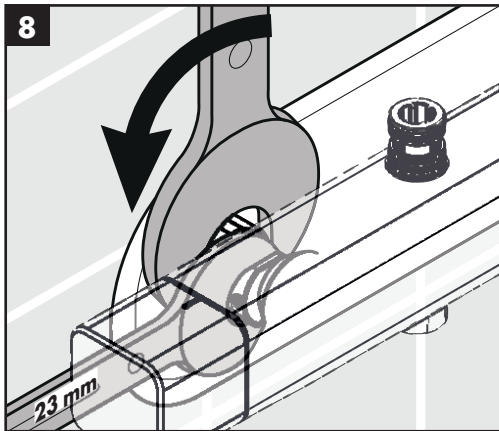
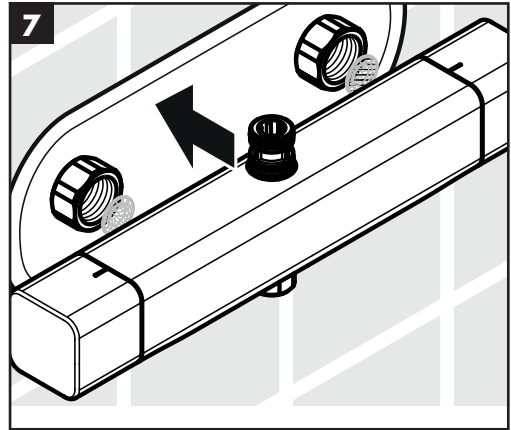
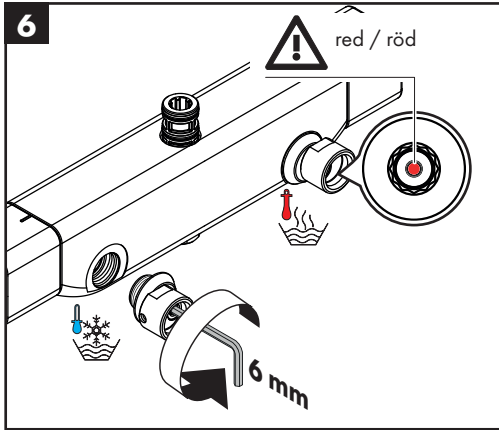



**EN** Cleaning recommendation / Warranty / Contact

**SV** Rengöringsrekommendationer / Garanti / Contacto

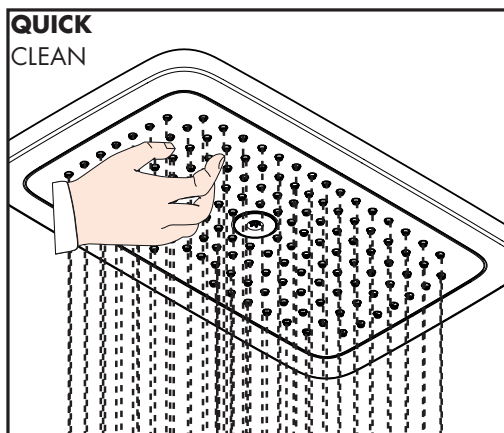

**EN** Just clean: simply rub over the spray nozzles to remove lime scale.

**SV** Enkelt att göra rent: det är lätt att ta bort kalk från nopporna.



[www.hansgrohe.com/  
cleaning-recommendation](http://www.hansgrohe.com/cleaning-recommendation)

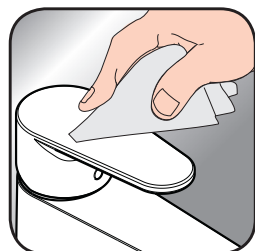

[www.hansgrohe.com/  
cleaning-recommendation](http://www.hansgrohe.com/cleaning-recommendation)



[www.hansgrohe.com/  
cleaning-recommendation](http://www.hansgrohe.com/cleaning-recommendation)



[www.hansgrohe.com/  
cleaning-recommendation](http://www.hansgrohe.com/cleaning-recommendation)

