

Instructions for Use

Easytop circulation regulation valve S/E, thermostatic regulation valve with G-thread



for thermal / hydraulic line calibration in drinking water installations

Model
2281.15

Year built (from)
06/2011

viega

Table of contents

| | | |
|----------|---|-----------|
| 1 | About these instructions for use | 3 |
| | 1.1 Target groups | 3 |
| | 1.2 Labelling of notes | 3 |
| | 1.3 About this translated version | 4 |
| 2 | Product information | 5 |
| | 2.1 Standards and regulations | 5 |
| | 2.2 Intended use | 7 |
| | 2.2.1 Areas of use | 7 |
| | 2.2.2 Media | 7 |
| | 2.3 Product description | 8 |
| | 2.3.1 Overview | 8 |
| | 2.3.2 Threaded connection | 8 |
| | 2.3.3 Markings on components | 9 |
| | 2.3.4 Compatible components | 9 |
| | 2.3.5 Operating mode | 9 |
| | 2.3.6 Technical data | 10 |
| | 2.4 Information for use | 13 |
| | 2.4.1 Corrosion | 13 |
| | 2.5 Optional accessories | 13 |
| 3 | Handling | 15 |
| | 3.1 Assembly information | 15 |
| | 3.1.1 Mounting instructions | 15 |
| | 3.1.2 Required tools | 16 |
| | 3.2 Assembly | 16 |
| | 3.2.1 Installation position and settings | 16 |
| | 3.2.2 Mounting Easytop drainage valve and Easytop thermometer | 18 |
| | 3.2.3 Thermal disinfection | 19 |
| | 3.2.4 Leakage test | 20 |
| | 3.3 Maintenance | 20 |
| | 3.4 Disposal | 20 |

1 About these instructions for use

Trade mark rights exist for this document; for further information, go to viega.com/legal.

1.1 Target groups

The information in this manual is directed at heating and sanitary professionals and trained personnel.

Individuals without the abovementioned training or qualification are not permitted to mount, install and, if required, maintain this product. This restriction does not extend to possible operating instructions.

The installation of Viega products must take place in accordance with the general rules of engineering and the Viega instructions for use.

1.2 Labelling of notes

Warning and advisory texts are set aside from the remainder of the text and are labelled with the relevant pictographs.



DANGER!

This symbol warns of possible life-threatening injury.



WARNING!

This symbol warns of possible serious injury.



CAUTION!

This symbol warns of possible injury.



NOTICE!

This symbol warns of possible damage to property.



This symbol gives additional information and hints.

1.3 About this translated version

This instruction for use contains important information about the choice of product or system, assembly and commissioning as well as intended use and, if required, maintenance measures. The information about the products, their properties and application technology are based on the current standards in Europe (e. g. EN) and/or in Germany (e. g. DIN/DVGW).

Some passages in the text may refer to technical codes in Europe/Germany. These should serve as recommendations in the absence of corresponding national regulations. The relevant national laws, standards, regulations, directives and other technical provisions take priority over the German/European directives specified in this manual: The information herein is not binding for other countries and regions; as said above, they should be understood as a recommendation.

2 Product information

2.1 Standards and regulations

The following standards and regulations apply to Germany / Europe and are provided as a support feature.

Regulations from section: Fields of application

| Scope / Notice | Regulations applicable in Germany |
|---|-----------------------------------|
| Planning, execution, operation and maintenance of potable water installations | DIN EN 806, part 1 |
| Planning, execution, operation and maintenance of potable water installations | DIN EN 806, part 2 |
| Planning, execution, operation and maintenance of potable water installations | DIN EN 806, part 3 |
| Planning, execution, operation and maintenance of potable water installations | DIN EN 806, part 4 |
| Planning, execution, operation and maintenance of potable water installations | DIN EN 806, part 5 |
| Planning, execution, operation and maintenance of potable water installations | DIN EN 1717 |
| Planning, execution, operation and maintenance of potable water installations | DIN 1988 |
| Planning, execution, operation and maintenance of potable water installations | VDI/DVGW 6023 |
| Planning, execution, operation and maintenance of potable water installations | Trinkwasserverordnung (TrinkwV) |
| Planning, execution, operation and maintenance of potable water installations | DVGW-Arbeitsblatt W 553 |

Regulations from section: Media

| Scope / Notice | Regulations applicable in Germany |
|--------------------------------|-----------------------------------|
| Suitability for drinking water | Trinkwasserverordnung (TrinkwV) |

Regulations from section: Product description

| Scope / Notice | Regulations applicable in Germany |
|--|-----------------------------------|
| Suitability for drinking water installations | Trinkwasserverordnung (TrinkwV) |
| Suitability for drinking water installations | DIN 50930-6 |
| Requirements in plastic components in drinking water installations | DVGW-Arbeitsblatt W270 |

Regulations from section: Compatible components

| Scope / Notice | Regulations applicable in Germany |
|--------------------|-----------------------------------|
| G-external threads | DIN EN ISO 228 |

Regulations from section: Corrosion

| Scope / Notice | Regulations applicable in Germany |
|-------------------------------|-----------------------------------|
| External corrosion protection | DIN EN 806-2 |
| External corrosion protection | DIN 1988-200 |
| External corrosion protection | DKI-Informationsdruck i. 160 |

Regulations from section: Installation position and settings

| Scope / Notice | Regulations applicable in Germany |
|-------------------------------------|-----------------------------------|
| Dimensioning of circulation systems | DVGW-Arbeitsblatt W 553 |

Regulations from section: Leakage test

| Scope / Notice | Regulations applicable in Germany |
|--|--|
| Leakage test for potable water installations | DIN EN 806, part 4 |
| Leakage test for potable water installations | ZVSHK-Merkblatt „Dichtheitsprüfungen von Trinkwasserinstallationen mit Druckluft, Inertgas oder Wasser“ |

Regulations from section: Maintenance

| Scope / Notice | Regulations applicable in Germany |
|--|-----------------------------------|
| Operation and maintenance of potable water installations | DIN EN 806-5 |

2.2 Intended use



Coordinate the use of the model for areas of use and media other than those described with the Viega Service Center.

The functionality of the valve is only ensured by professional design and assembly of the complete system.

2.2.1 Areas of use

Use is possible in the following areas among others:

- Hot water circulation pipelines
- Internally and parallel laid circulation pipes

The general rules of engineering and the applicable regulations must be observed for planning, execution, operation and maintenance potable water installations, see ↪ *'Regulations from section: Fields of application'* on page 5.

2.2.2 Media

The model is also suitable for the following media, amongst others:

- Drinking water without limitations acc. to the applicable directives, see ↪ *'Regulations from section: Media'* on page 6
- maximum chloride concentration 250 mg/l pursuant to applicable regulations, see ↪ *'Regulations from section: Media'* on page 6

2.3 Product description

According to the applicable regulations, Easytop system fittings can be used for all types of potable water and are DVGW certified, see [☞ 'Regulations from section: Product description' on page 6](#). Their plastic components comply with the KTW recommendation and the requirements pursuant to the applicable regulations.

2.3.1 Overview

The model is equipped as follows:

- valve casing made of gunmetal/silicon bronze
- dual-sided G external thread
- drain plugs for drainage valve G $\frac{1}{4}$
- regulating unit with valve cone and flexible material element
- temperature scale for setting temperature between 40 °C and 65 °C
- integrated ball valve
- converter flow regulator

The model can be shut off using the integrated ball valve.

The model is available in the following dimensions:

| | | |
|----|---------------|----|
| G | $\frac{3}{4}$ | 1 |
| DN | 15 | 20 |

2.3.2 Threaded connection

Only flat sealing connection screw fittings may be used for the threaded connection.



Sealing of the G-threads takes place by pressing the sealing surfaces together. For this reason, no additional sealants (hemp, sealing paste / thread etc.) may be used.

2.3.3 Markings on components

The model is marked as follows:

- flow direction indicator
- dimension
- DVGW writing
- position indicator for operating mode

2.3.4 Compatible components

The model is equipped with G-external threads according to the applicable regulations and compatible with the Profipress, Sanpress, and Sanpress Inox system, see ↗ *'Regulations from section: Compatible components'* on page 6.

2.3.5 Operating mode

Circulation regulation valve (CRV)

The valve cone of the CRV is equipped with a flexible material element. The flexible material element reacts to changes in the temperature of the hot water in the circulation circuit.

| | |
|---|---|
| Difference between target and actual value: | CRV changes flowthrough volume and regulates the water temperature in this way. |
| Target value below target: | Valve opens. |
| Target value exceeded: | Valve closes. |
| Target value and actual value match: | Hydraulic / thermal calibration is completed. |

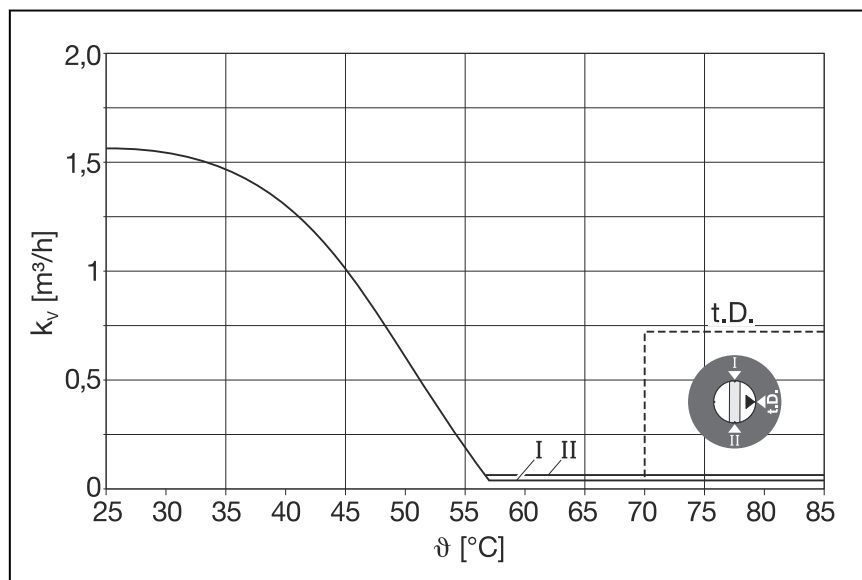

Fig. 1: Diagram minimum flowthrough / temperature

2.3.6 Technical data

Observe the following operating conditions for the installation of the model:

| | |
|-------------------------------------|-------------------|
| Operating temperature [T_{max}] | 90 °C |
| Operating pressure [P_{max}] | 1.0 MPa (10 bar) |
| Temperature range (settable) | 40 °C up to 65 °C |
| Factory settings | 57 °C |

Pressure loss

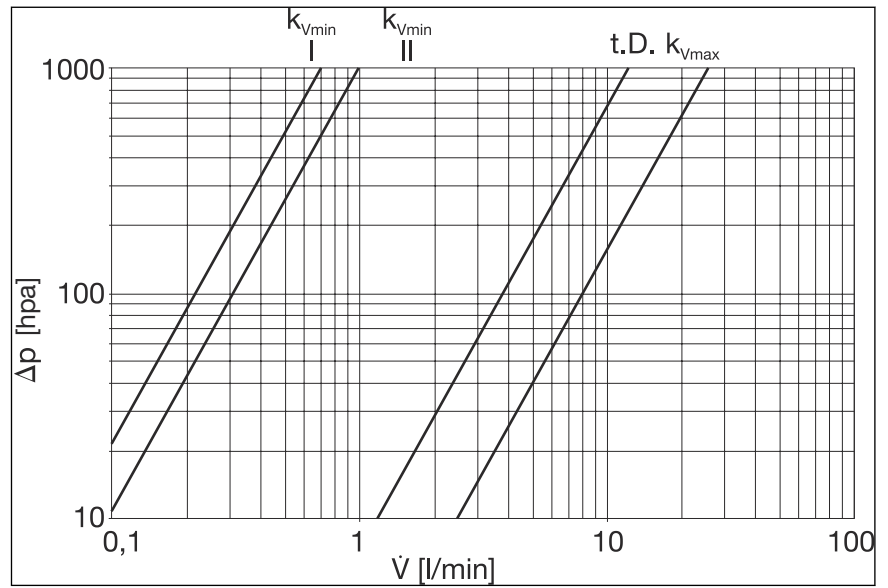

Fig. 2: Diagram operating modes / Pressure losses

Setting the flowthrough regulation

| Switch position | Minimum flow-through in m ³ / h | Maximum flow-through in m ³ / h |
|-----------------|--|--|
| I | on the storey: 0.042 | on the storey: 1.542 |
| II | in the riser pipe: 0.060 | in the riser pipe: 1.560 |
| t. D. | | thermal disinfection at 70 °C: 0.72 |

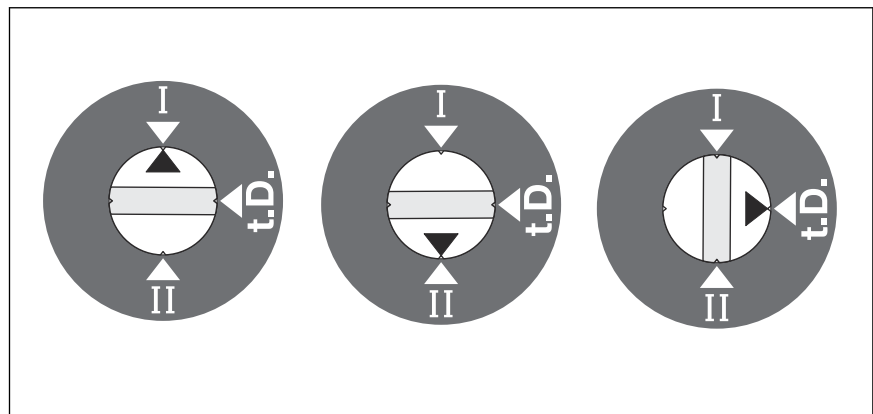

Fig. 3: CRV flowthrough regulation

The flowing values are valid for kV [Δp 1000 hPa (1000 mbar)]:

| Temperature & setting ° C | 65 | 60 | 57 | 55 | 50 | 45 | 40 | Flowthrough m ³ /h switch I | Flowthrough m ³ /h switch II |
|---------------------------|------|------|------|------|------|------|------|--|---|
| Flowthrough temperature | 65.0 | 60.0 | 57.5 | 55.0 | 50.0 | 45.0 | 40.0 | 0.042 | 0.060 |
| | 60.0 | 57.5 | 55.0 | 52.5 | 47.5 | 42.5 | 37.5 | 0.258 | 0.276 |
| | 57.5 | 55.0 | 52.5 | 50.0 | 45.0 | 40.0 | 35.0 | 0.407 | 0.425 |
| | 55.0 | 52.5 | 50.0 | 47.5 | 42.5 | 37.5 | 32.5 | 0.618 | 0.636 |
| | 52.5 | 50.0 | 47.5 | 45.0 | 40.0 | 35.0 | 30.0 | 0.803 | 0.521 |
| | 50.0 | 47.5 | 45.0 | 42.5 | 37.5 | 32.5 | 27.5 | 1.056 | 1.074 |
| | 47.5 | 45.0 | 42.5 | 40.0 | 35.0 | 30.0 | 25.0 | 1.178 | 1.196 |
| | 45.0 | 42.5 | 40.0 | 37.5 | 32.5 | 27.5 | 22.5 | 1.296 | 1.314 |
| | 42.5 | 40.0 | 37.5 | 35.0 | 30.0 | 25.0 | 20.0 | 1.325 | 1.400 |
| | 40.0 | 37.5 | 35.0 | 32.5 | 27.5 | 22.5 | - | 1.497 | 1.497 |
| | 37.5 | 35.0 | 32.5 | 30.0 | 25.0 | 20.0 | - | 1.488 | 1.506 |
| | 35.0 | 32.5 | 30.0 | 27.5 | 22.5 | - | - | 1.506 | 1.524 |

2.4 Information for use

2.4.1 Corrosion

Overground pipelines and fittings in rooms do not normally require external corrosion protection.

There are exceptions in the following cases:

- Contact with aggressive building materials such as nitrite or materials containing ammonium
- in aggressive surroundings

If external corrosion protection is required, observe the pertinent guidelines, see ↗ *'Regulations from section: Corrosion' on page 6.*



Easytop fittings made of gunmetal/silicon bronze are suitable for all types of potable water.

The chloride concentration in the medium must not exceed a maximum value of 250 mg/l.

This chloride is not a disinfectant, but in fact pertains to the content in sea and table salt (sodium chloride).

2.5 Optional accessories

The following optional accessories are available:

- Actuator set
- Drainage valve
- Thermometer
- Insulating shell



Fig. 4: Model 1013.9 Easytop actuator set

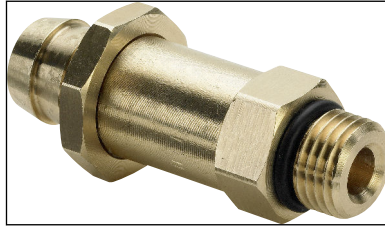

Fig. 5: Model 2234.6 Easytop drainage valve



Fig. 6: Model 1026.6 Easytop thermometer



Fig. 7: Model 2210.30 Easytop insulating shell

An EPS insulating shell is available for the circulation regulation valve. The two-piece insulating shell is self-supporting and is mounted without tools and holding grips. They close seamlessly on the front surface of the pipeline insulation.

3 Handling

3.1 Assembly information

3.1.1 Mounting instructions

Checking system components



Do not remove the model from the packaging until immediately before use.

System components may, in some cases, become damaged through transportation and storage.

- Check all parts.
- Replace damaged components.
- Do not repair damaged components.
- Contaminated components may not be installed.

During assembly

Observe the following when mounting:

- use suitable tools
- flow direction indicator
- When tightening the connection screw fitting, counter by holding the key surface of the valve.



Choose the place of installation so that the fitting is easy to access and to operate, and that the insulating shell and if applicable the Easytop actuator set can be mounted without any problems.

Laying and fixing pipes

For information, refer to the instructions for use of the Viega system of the product you are using.

Length expansion

For information, refer to the instructions for use of the Viega system of the product you are using.

3.1.2 Required tools

Temperature setting

An Allen key (size 6) is required to set the temperature.

Removal drain plugs

An Allen key (size 5) is required to remove the drain plug.

3.2 Assembly

3.2.1 Installation position and settings

Installation position

Installation is possible in both the riser pipe and on the storey.

If there are multiple riser pipes on the storey during the installation of the circulation regulation valve, then every riser pipe must have a circulation regulation valve mounted, see ↪ Fig. 9.



NOTICE!

According to the applicable directives, circulation regulation valves must be installed between the outlet of the hot water tank and the circulation inlet, see ↪ 'Regulations from section: Installation position and settings' on page 6.

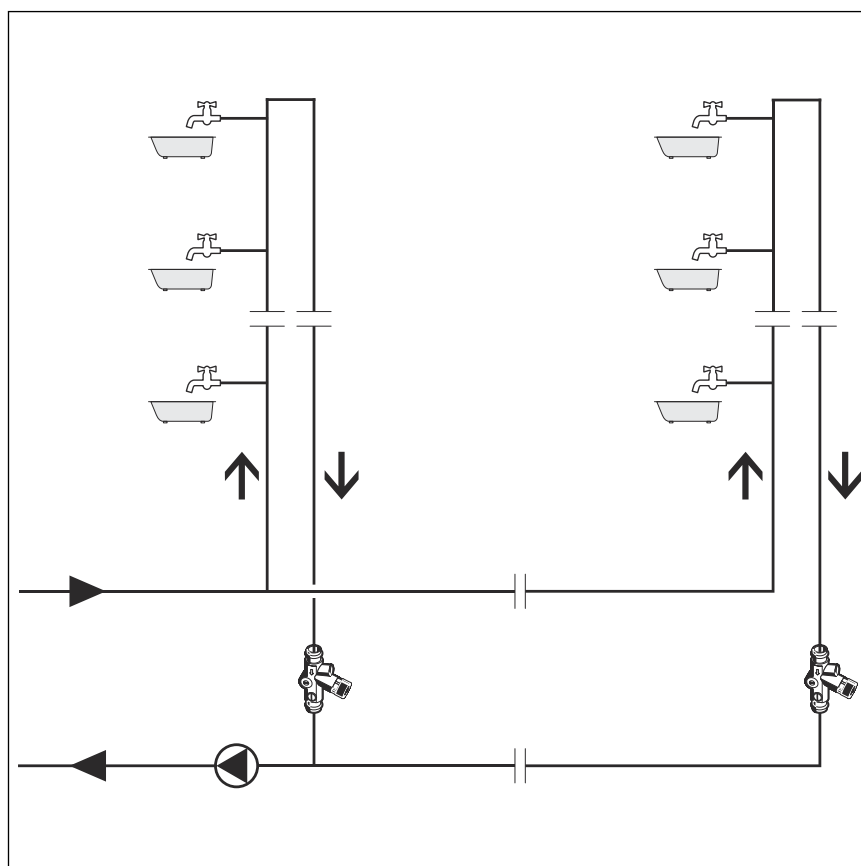

Fig. 8: CRV in the riser pipe

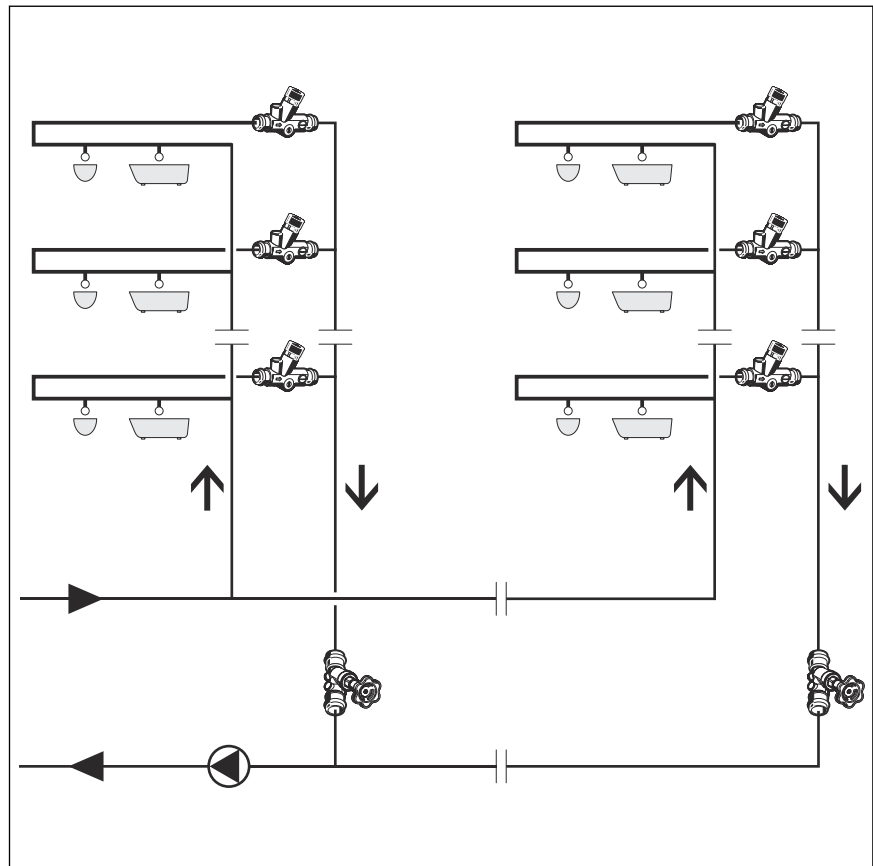

Fig. 9: CRV on the storey

Settings

- Set the temperature and flow regulation before commissioning.
- Use in the section: Bring flowthrough control to position II.
- Use on the storey: Bring flowthrough control to position I.
- For thermal disinfection: Bring flowthrough control to position t.D..
- Temperature setting: Set to calculated target value.

Temperature setting

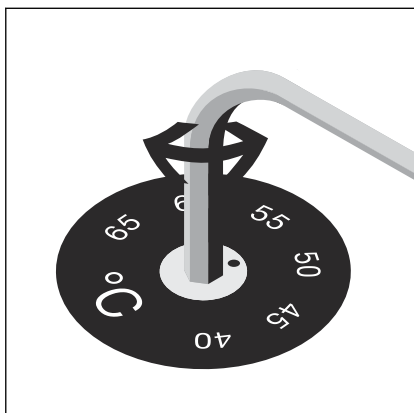

Fig. 10: CRV set temperature

An Allen key (size 6) is required to set the temperature.

- Set temperature at the temperature control valve with Allen key (size 6).

3.2.2 Mounting Easytop drainage valve and Easytop thermometer

Mounting is demonstrated with the example model 2281.5.

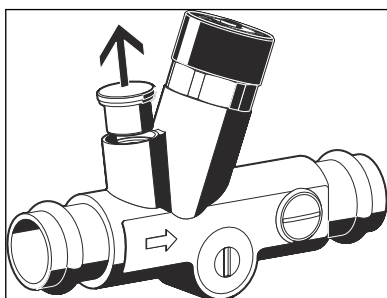

- Unscrew the drain plugs with an Allen key (size 5).

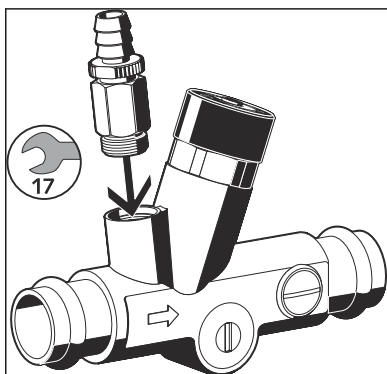

- Insert Easytop drainage valve and tighten using a fork spanner (size 17). Sealing is achieved using an O-Ring.

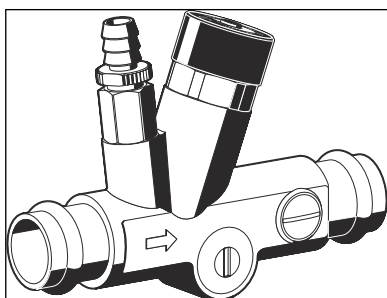

The Easytop drainage valve has the following functions:

- Draining
- Seat sensor actuator set
- Seat Easytop thermometer

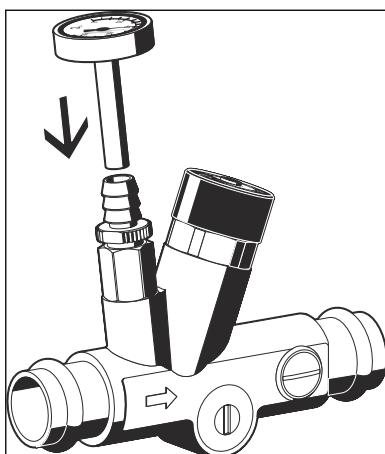

- Insert the Easytop thermometer into the closed Easytop drainage valve.

3.2.3 Thermal disinfection



CAUTION!

Risk of scalding from hot water!

Inform users and secure extraction point before beginning the flushing process.

Mode of operation

Contaminated drinking water installations can be disinfected by short-term flushing with hot water with a temperature of 70 °C. Thermal disinfection is achieved by flushing all parts that come into contact with water with hot water with a temperature of 70 °C for at least 3 minutes.

To avoid injury due to hot water, the process must be discussed with the system's users.

Procedure

In units with more than one system, the circuits are disinfected individually one after another. Proceed as follows:

- Heat the hot water temperature to at least 70 °C.
- Close the ball valves on the Easytop circulation regulation valves of the lines not in use.
- Place the converter for the flowthrough regulator on the Easytop circulation regulation valve to position **t.D.**
- Open every extraction fitting fully and flush for at least 3 minutes after 70 °C has been reached.
- Place the flowthrough regulator and ball valve in the operating position.
- Do exactly the same with all of the circulation circuits.



NOTICE!

Thermal disinfection can be carried out automatically in combination with a building automation (on-site) and the Easytop actuator set model 1013.9. Manual adjustment of the valve is no longer necessary.

3.2.4 Leakage test

The installer must perform a leakage test before commissioning.

Carry out this test on a system that is finished but not yet covered.

Comply with the general rules of engineering and the applicable directives, see ↗ *'Regulations from section: Leakage test' on page 7.*

Document the result.

3.3 Maintenance



NOTICE!

Inform your customer or the operator of the drinking water installation that the system has to be maintained on a regular basis.

Observe the applicable regulations for the operation and maintenance of drinking water installations, see ↗ *'Regulations from section: Maintenance' on page 7.*

3.4 Disposal

Separate the product and packaging materials (e. g. paper, metal, plastic or non-ferrous metals) and dispose of in accordance with valid national legal requirements.



Viega GmbH & Co. KG
service-technik@viega.de
viega.com

INT • 2022-08 • VPN180164

