

hansgrohe

DE	Gebrauchsanleitung / Montageanleitung	2			
FR	Mode d'emploi / Instructions de montage	3			
EN	Instructions for use / assembly instructions	4			
IT	Istruzioni per l'uso / Istruzioni per l'installazione	5	Talis Classic	Metropol S	PuraVida
ES	Modo de empleo / Instrucciones de montaje	6	14145000	14465000	15445XXX
NL	Gebruiksaanwijzing / Handleiding	7	14146000	14466000	15447XXX
DK	Brugsanvisning / Monteringsvejledning	8			
PT	Instruções para uso / Manual de Instalação	9			
PL	Instrukcja obsługi / Instrukcja montażu	10			
CS	Návod k použití / Montážní návod	11			
SK	Návod na použitie / Montážny návod	12	Metris	Metris S	Metris Classic
ZH	用户手册 / 组装说明	13	31451000	31465000	31485000
RU	Руководство пользователя / Инструкция по монтажу		31454000	31466000	31486000
HU	Használati útmutató / Szerelési útmutató	14			
FI	Käyttöohje / Asennusohje	15			
SV	Bruksanvisning / Monteringsanvisning	16			
LT	Vartotojo instrukcija / Montavimo instrukcijos	17			
HR	Upute za uporabu / Uputstva za instalaciju	18	Metris	Talis E²	Focus S
TR	Kullanım kılavuzu / Montaj kılavuzu	19	31493000	31645000	31743000
RO	Manual de utilizare / Instrucțiuni de montare	20	31487000	31646000	
EL	Οδηγίες χρήσης / Οδηγία συναρμολόγησης	21			
SL	Navodilo za uporabo / Navodila za montažo	22			
ET	Kasutusjuhend / Paigaldusjuhend	23			
LV	Lietošanas pamācība / Montāžas instrukcija	24		Focus	Talis S / Talis
SR	Uputstvo za upotrebu / Uputstvo za montažu	25	Focus E	31945000	32475000
NO	Bruksanvisning / Montasjeveiledning	26	31744000	31946000	32477000
BG	Инструкция за употреба / Ръководство за монтаж	27			
SQ	Udhëzuesi i përdorimit / Udhëzime rreth montimit	28			
AR	دليل الاستخدام / تعليمات التجميع	29			
		30	Logis		
			71405000		



Deutsch

Sicherheitshinweise

- ⚠ Bei der Montage müssen zur Vermeidung von Quetsch- und Schnittverletzungen Handschuhe getragen werden.
- ⚠ Das Produkt darf nur zu Bade-, Hygiene- und Körperreinigungszwecken eingesetzt werden.
- ⚠ Große Druckunterschiede zwischen den Kalt- und Warmwasseranschlüssen müssen ausgeglichen werden.

Montagehinweise

- Vor der Montage muss das Produkt auf Transportschäden untersucht werden. Nach dem Einbau werden keine Transport- oder Oberflächenschäden anerkannt.
- Die Leitungen und die Armatur müssen nach den gültigen Normen montiert, gespült und geprüft werden.
- Die in den Ländern jeweils gültigen Installationsrichtlinien sind einzuhalten.

Technische Daten

Betriebsdruck:	max. 1 MPa
Empfohlener Betriebsdruck:	0,1 - 0,5 MPa
Prüfdruck:	1,6 MPa
(1 MPa = 10 bar = 147 PSI)	
Heißwassertemperatur:	max. 80 °C
Empfohlene Heißwassertemperatur:	65 °C
Thermische Desinfektion:	max. 70 °C / 4 min

14146000 / 14466000 / 15447XXX / 31451000 / 31466000 / 31486000 / 31487000 / 31646000 / 31946000 / 32477000: Eigensicher gegen Rückfließen

Das Produkt ist ausschließlich für Trinkwasser konzipiert!

Symbolerklärung



Kein essigsäurehaltiges Silikon verwenden!



Justierung (siehe Seite 33)

Einstellen der Warmwasserbegrenzung. In Verbindung mit Durchlauferhitzern ist eine Warmwassersperre nicht zu empfehlen.



Maße (siehe Seite 34)



Durchflussdiagramm
(siehe Seite 35)

- ① Abgang Brause
- ② Abgang Wanne



Bedienung (siehe Seite 41)



Wartung (siehe Seite 36)

14146000 / 14466000 / 15447XXX / 31451000 / 31466000 / 31486000 / 31487000 / 31646000 / 31946000 / 32477000: Die Sicherheitseinrichtungen müssen gemäß DIN EN 1717 regelmäßig in Übereinstimmung mit nationalen oder regionalen Bestimmungen (DIN 1988 einmal jährlich) auf ihre Funktion geprüft werden.



Reinigung (siehe beiliegende Broschüre)



Serviceteile (siehe Seite 38)



Prüfzeichen (siehe Seite 48)

Störung	Ursache	Abhilfe
Armatur schwergängig	- Kartusche defekt, verkalkt	- Kartusche austauschen
Armatur tropft	- Kartusche defekt	- Kartusche austauschen
Zu niedrige Warmwassertemperatur, kein Kaltwasser. Durchlauferhitzer springt an, wenn Kaltwasser angewählt wird.	- Warmwasserbegrenzung falsch eingestellt	- Warmwasserbegrenzung einstellen
	- Kreuzfluss	- Kartusche austauschen
Umsteller funktioniert nicht	- Ablagerungen	- Umsteller reinigen / O-Ringe fetten
	- Zu geringer Wasserdruck	- Wasserdruck erhöhen
	- Umsteller defekt	- Umsteller austauschen



Montage siehe Seite 31



Consignes de sécurité

- ⚠ Lors du montage, porter des gants de protection pour éviter toute blessure par écrasement ou coupure.
- ⚠ Le système de douche ne doit servir qu'à se laver et à assurer l'hygiène corporelle.
- ⚠ Il est conseillé d'équilibrer les pressions de l'eau chaude et froide.

Instructions pour le montage

- Avant son montage, s'assurer que le produit n'a subi aucun dommage pendant le transport. Après le montage, tout dommage de transport ou de surface ne pourra pas être reconnu.
- Les conduites et la robinetterie doivent être montés, rincés et contrôlés selon les normes en vigueur.
- Les directives d'installation en vigueur dans le pays concerné doivent être respectées.

Informations techniques

Pression de service autorisée:	max. 1 MPa
Pression de service conseillée:	0,1 - 0,5 MPa
Pression maximum de contrôle: (1 MPa = 10 bar = 147 PSI)	1,6 MPa
Température d'eau chaude:	max. 80 °C
Température recommandée:	65 °C
Désinfection thermique:	max. 70 °C / 4 min

14146000 / 14466000 / 15447XXX / 31451000 / 31466000 / 31486000 / 31487000 / 31646000 / 31946000 / 32477000: Avec dispositif anti-retour

Le produit est exclusivement conçu pour de l'eau potable!

Description du symbole



Ne pas utiliser de silicone contenant de l'acide acétique!



Etalonnage (voir pages 33)

Réglage de la limitation d'eau chaude. En liaison avec les chauffe-eau, un blocage de l'eau chaude n'est pas recommandable.



Dimensions (voir pages 34)



Diagramme du débit

(voir pages 35)

- ① Sortie douche
- ② Sortie baignoire



Instructions de service (voir pages 41)



Entretien (voir pages 36)

14146000 / 14466000 / 15447XXX / 31451000 / 31466000 / 31486000 / 31487000 / 31646000 / 31946000 / 32477000: Les clapets anti-retour doivent être examinés régulièrement conformément à la norme EN 1717 ou conformément aux dispositions nationales ou régionales quant à leur fonction (au moins une fois par an).



Nettoyage (voir la brochure ci-jointe)



Pièces détachées (voir pages 38)



Classification acoustique et débit (voir pages 48)

Dysfonctionnement	Origine	Solution
Durété de fonctionnement	- Cartouche défectueuse, entartrée	- Changer la cartouche
Le mitigeur goutte	- Cartouche défectueuse	- Changer la cartouche
Température d'eau chaude trop basse, pas d'eau froide. Le chauffe eau instantané met en route quand on puise de l'eau froide.	- Limiteur de température mal positionné - Flux inversé	- Positionner le limiteur de température - Changer la cartouche
L'inverseur ne fonctionne pas	- Dépôts - Pression d'alimentation insuffisante - Inverseur défectueux	- Nettoyer l'inverseur / graisser les joints toriques - Augmenter la pression d'alimentation - Changez l'inverseur



Montage voir pages 31



English

Safety Notes

- ⚠ Gloves should be worn during installation to prevent crushing and cutting injuries.
- ⚠ The shower system may only be used for bathing, hygienic and body cleaning purposes.
- ⚠ The hot and cold supplies must be of equal pressures.

Installation Instructions

- Prior to installation, inspect the product for transport damages. After it has been installed, no transport or surface damage will be honoured.
- The pipes and the fixture must be installed, flushed and tested as per the applicable standards.
- The plumbing codes applicable in the respective countries must be observed.

Technical Data

Operating pressure:	max. 1 MPa
Recommended operating pressure:	0,1 - 0,5 MPa
Test pressure:	1,6 MPa
(1 MPa = 10 bar = 147 PSI)	
Hot water temperature:	max. 80 °C
Recommended hot water temp.:	65 °C
Thermal disinfection:	max. 70 °C / 4 min

14146000 / 14466000 / 15447XXX / 31451000 / 31466000 / 31486000 / 31487000 / 31646000 / 31946000 / 32477000: Safety against backflow

The product is exclusively designed for drinking water!

Symbol description



Do not use silicone containing acetic acid!



Adjustment (see page 33)

To adjust the hot water limiter. Using a hot water limiter in combination with a continuous flow water heater is not recommended.



Dimensions (see page 34)



Flow diagram

(see page 35)

① Shower outlet

② Tub outlet



Operation (see page 41)



Maintenance (see page 36)

14146000 / 14466000 / 15447XXX / 31451000 / 31466000 / 31486000 / 31487000 / 31646000 / 31946000 / 32477000: The safety device must be checked regularly according to DIN EN 1717 in accordance with national or regional regulations (at least once a year).



Cleaning (see enclosed brochure)



Spare parts (see page 38)



Test certificate (see page 48)

Fault	Cause	Remedy
Mixer stiff	- Cartridge defective, calcified	- Exchange cartridge
Mixer dripping	- Cartridge defective	- Exchange cartridge
Hot water temperature too low, no cold water. Instantaneous water heater starts up when cold water is selected.	- Hot water limiter incorrectly set	- Set hot water limiter
	- Crossflow	- Exchange cartridge
Diverter not operating	- Residue	- Clean converter / grease O-rings
	- Water pressure too low	- Increase water pressure
	- Diverter defective	- Exchange diverter



Assembly see page 31



Indicazioni sulla sicurezza

- ⚠ Durante il montaggio, per evitare ferite da schiacciamento e da taglio bisogna indossare guanti protettivi.
- ⚠ Il sistema doccia deve essere utilizzato esclusivamente per l'igiene del corpo.
- ⚠ Attenzione! Compensare le differenze di pressione tra i collegamenti dell'acqua fredda e dell'acqua calda.

Istruzioni per il montaggio

- Prima del montaggio è necessario controllare che non ci siano stati danni durante il trasporto. Una volta eseguito il montaggio, non verranno riconosciuti eventuali danni di trasporto o delle superfici.
- Montare, lavare e controllare tubature e rubinetteria rispettando le norme correnti.
- Vanno rispettate le direttive di installazione nazionali vigenti nel rispettivo paese.

Dati tecnici

Pressione d'uso: max. 1 MPa
 Pressione d'uso consigliata: 0,1 - 0,5 MPa
 Pressione di prova: 1,6 MPa
 (1 MPa = 10 bar = 147 PSI)
 Temperatura dell'acqua calda: max. 80 °C
 Temp. dell'acqua calda consigliata: 65 °C
 Disinfezione termica: max. 70 °C / 4 min

14146000 / 14466000 / 15447XXX / 31451000 /
 31466000 / 31486000 / 31487000 / 31646000 /
 31946000 / 32477000: Sicurezza antiriflusso

Il prodotto è concepito esclusivamente per acqua potabile!

Descrizione simbolo



Non utilizzare silicone contenente acido acetico!



Taratura (vedi pagg. 33)
 Regolazione del limitatore di erogazione d'acqua calda. Un limitatore di erogazione di acqua calda in combinazione con le caldaie istantanee non è consigliabile.



Ingombri (vedi pagg. 34)



Diagramma flusso
 (vedi pagg. 35)

- ① uscita doccia
- ② uscita vasca



Procedura (vedi pagg. 41)



Manutenzione (vedi pagg. 36)

14146000 / 14466000 / 15447XXX /
 31451000 / 31466000 / 31486000 /
 31487000 / 31646000 / 31946000 /
 32477000: La valvola di non ritorno deve essere controllata regolarmente come da DIN EN 1717, secondo le normative nazionali e regionali (almeno una volta all'anno).



Pulitura (vedi il prospetto accluso)



Parti di ricambio (vedi pagg. 38)



Segno di verifica (vedi pagg. 48)

Problema	Possibile causa	Rimedio
Miscelatore duro	- Cartuccia difettosa	- Sostituire la cartuccia
Miscelatore gocciola	- Cartuccia difettosa	- Sostituire la cartuccia
Temperatura dell'acqua calda troppo bassa, niente acqua fredda, caldaia istantanea si accende quando si seleziona acqua fredda	- Limitazione dell'acqua calda regolata male - Flusso incrociato	- Regolare la limitazione dell'acqua calda - Sostituire la cartuccia
Deviatore non funziona	- depositi calcarei - pressione d'acqua troppo bassa - deviatore difettoso	- pulire il regolatore / ingrassare le guarnizioni O-ring - alzare la pressione d'acqua - sostituire deviatore



Montaggio vedi pagg. 31



Español

Indicaciones de seguridad

- ⚠ Durante el montaje deben utilizarse guantes para evitar heridas por aplastamiento o corte.
- ⚠ La grifería solo debe ser utilizada para fines de baño, higiene y limpieza corporal.
- ⚠ Grandes diferencias de presión en servicio entre agua fría y agua caliente deben equilibrarse.

Indicaciones para el montaje

- Antes del montaje se debe examinar el producto contra daños de transporte. Después de la instalación so se reconoce ningún daño de transporte o de superficie.
- Los conductos y la grifería deben montarse, lavarse y comprobarse según las normas vigentes.
- Es obligatorio el cumplimiento de las directrices de instalación vigentes en el país respectivo.

Datos técnicos

Presión en servicio:	max. 1 MPa
Presión recomendada en servicio:	0,1 - 0,5 MPa
Presión de prueba: (1 MPa = 10 bar = 147 PSI)	1,6 MPa
Temperatura del agua caliente:	max. 80 °C
Temp. recomendada del agua caliente:	65 °C
Desinfección térmica:	max. 70 °C / 4 min

14146000 / 14466000 / 15447XXX / 31451000 /
31466000 / 31486000 / 31487000 / 31646000 /
31946000 / 32477000: Seguro contra el retorno

El producto ha sido concebido exclusivamente para agua potable.

Descripción de símbolos



No utilizar silicona que contiene ácido acético!



Ajuste (ver página 33)

Ajuste del límite de agua caliente. En combinación con calentadores continuos no es recomendable utilizar un bloqueo de agua caliente.



Dimensiones (ver página 34)



Diagrama de circulación
(ver página 35)

- ① Salida surtidor de ducha
- ② Salida bañera



Manejo (ver página 41)



Mantenimiento (ver página 36)

14146000 / 14466000 / 15447XXX /
31451000 / 31466000 / 31486000 /
31487000 / 31646000 / 31946000 /
32477000: Las válvulas anti-retorno tienen que ser controladas regularmente según la norma DIN EN 1717, en acuerdo con las regulaciones nacionales o regionales (una vez al año, por lo menos).



Limpiar (ver el folleto adjunto)



Repuestos (ver página 38)



Marca de verificación (ver página 48)

Problema	Causa	Solución
Manecilla va dura	- cartucho dañado	- cambiar el cartucho
Grifo pierde agua	- cartucho dañado	- cambiar el cartucho
Temperatura del agua caliente demasiado baja, agua fría calentador se dispara al abrir agua fría	- tope de agua caliente mal - Flujo cruzado	- ajustar tope - cambiar el cartucho
Inversor no funciona	- Depósitos - falta presión - inversor defecto	- Limpiar conmutador de tomas / engrasar anillos tóricos - aumentar presión - cambiar inversor



Montaje ver página 31



Veiligheidsinstructies

- ⚠ Bij de montage moeten ter voorkoming van knel- en snijwonden handschoenen worden gedragen.
- ⚠ Het douchesysteem mag alleen voor het wassen, hygiënische doeleinden en voor de lichaamreiniging worden gebruikt.
- ⚠ Grote drukverschillen tussen de koud- en warmwater-toevoer dienen vermeden te worden.

Montage-instructies

- Vóór de montage moet het product gecontroleerd worden op transportschade. Na de inbouw wordt geen transport- of oppervlakteschade meer aanvaard.
- De leidingen en armaturen moeten gemonteerd, gespoeld en gecontroleerd worden volgens de geldige normen.
- De in de overeenkomstige landen geldende installatierichtlijnen moeten nageleefd worden.

Technische gegevens

Werkdruk: max. 1 MPa
 Aanbevolen werkdruk: 0,1 - 0,5 MPa
 Getest bij: 1,6 MPa
 (1 MPa = 10 bar = 147 PSI)
 Temperatuur warm water: max. 80 °C
 Aanbevolen warm water temp.: 65 °C
 Thermische desinfectie: max. 70 °C / 4 min

14146000 / 14466000 / 15447XXX / 31451000 /
 31466000 / 31486000 / 31487000 / 31646000 /
 31946000 / 32477000: Beveiligd tegen terugstromen

Het product is uitsluitend ontworpen voor drinkwater!

Symboolbeschrijving



Gebruik geen zuurhoudende silicone!



Instellen (zie blz. 33)

Instellen van de warmwaterbegrenzing. In combinatie met een doorstromer is een warmwaterblokkering niet aanbevelenswaardig.



Maten (zie blz. 34)



Doorstroombiagram (zie blz. 35)

- ① Uitlaat douche
- ② Uitlaat bad



Bediening (zie blz. 41)



Onderhoud (zie blz. 36)

14146000 / 14466000 / 15447XXX /
 31451000 / 31466000 / 31486000 /
 31487000 / 31646000 / 31946000 /
 32477000: Keerkleppen moeten volgens
 DIN EN 1717 regelmatig en volgens plaat-
 selijk geldende eisen op het functioneren
 gecontroleerd worden. (Tenminste een keer
 per jaar)



Reinigen (zie bijgevoegde brochure)



Service onderdelen (zie blz. 38)



Keurmerk (zie blz. 48)

Storing	Oorzaak	Oplossing
Bediening zwaar	- Kardoes defect of verkalkt	- Kardoes uitwisselen
Mengkraan lekt	- Kardoes defect	- Kardoes uitwisselen
Warmwater temperatuur te laag, geen koud water. Doorstroombiagram springt aan wanneer koud water gekozen is.	- Heetwaterbegrenzer verkeerd ingesteld	- Heetwaterbegrenzer instellen
	- Kruisstroom	- Kardoes uitwisselen
Omstelling functioneert niet	- Afzettingen	- Omsteller reinigen / O-ringen invetten
	- Waterdruk te laag	- Waterdruk verhogen
	- Omstelling defect	- Omstelling uitwisselen



Montage zie blz. 31



Dansk

Sikkerhedsanvisninger

- ⚠ Ved monteringen skal der bruges handsker for at undgå kvæstelser og snitsår.
- ⚠ Brusersystemet må kun bruges til bade-, hygiejne og rengøringsformål.
- ⚠ Større trykforskelle mellem koldt og varmt vand bør udjævnes.

Monteringsanvisninger

- Før monteringen skal produktet kontrolleres for transportskader. Efter monteringen godkendes transportskader eller skader på overfladen ikke længere.
- Ledningerne og armaturerne skal monteres, skylles og kontrolleres iht. de gældende standarder.
- Installationsbestemmelserne, der gælder i det enkelte land, skal overholdes.

Tekniske data

Driftstryk:	max. 1 MPa
Anbefalet driftstryk:	0,1 - 0,5 MPa
Prøvetryk:	1,6 MPa
(1 MPa = 10 bar = 147 PSI)	
Varmtvandstemperatur:	max. 80 °C
Anbefalet varmtvandstemperatur:	65 °C
Termisk desinfektion:	max. 70 °C / 4 min

14146000 / 14466000 / 15447XXX / 31451000 / 31466000 / 31486000 / 31487000 / 31646000 / 31946000 / 32477000: Med indbygget kontraventil

Produktet er udelukkende beregnet til drikkevand!

Symbolbeskrivelse



Der må ikke benyttes eddikesyreholdig silikone!



Forindstilling (se s. 33)

Indstilling af varmvandsbegrænsningen. I forbindelse med gennemstrømningsvandvarmere anbefaler vi ikke en varmvandsspærre.



Målene (se s. 34)



Gennemstrømningsdiagram (se s. 35)

- ① Afløb bruser
- ② Afløb kar



Brugsanvisning (se s. 41)



Service (se s. 36)

14146000 / 14466000 / 15447XXX / 31451000 / 31466000 / 31486000 / 31487000 / 31646000 / 31946000 / 32477000: Ifølge DIN EN 1717 skal gennemstrømningsbegrænsere i overensstemmelse med nationale regler afprøves regelmæssigt (mindst en gang om året).



Rengøring (se venligst den vedlagte brochure)



Reserve dele (se s. 38)



Godkendelse (se s. 48)

Fejl	Årsag	Hjælp
Grebet går trægt	- Kartusche defekt, tilkalket	- Udskift kartusche
Armaturet drypper	- Defekt kartusche	- Udskift kartusche
For lav varmtvandstemperatur. Ingen koldt vand. Vandvarmeren starter, når der åbnes for det kolde vand.	- Varmtvandsbegrænsningen er forkert indstillet	- Indstil varmtvandsbegrænsningen
Omstiller virker ikke	- Kryds-flow	- Udskift kartusche
	- Aflejring	- Rens omskifteren / smør O-ringe
	- For lavt vandtryk	- Forøg vandtrykket
	- Defekt omstiller	- Udskift omstilleren



Montering se s. 31



Avisos de segurança

- ⚠ Durante a montagem devem ser utilizadas luvas de protecção, de modo a evitar ferimentos resultantes de entalamentos e de cortes.
- ⚠ O sistema de duche só pode ser utilizado para fins de higiene pessoal.
- ⚠ Grandes diferenças entre as pressões das águas quente e fria devem ser compensadas.

Avisos de montagem

- Antes da montagem deve-se controlar o produto relativamente a danos de transporte. Após a montagem não são aceites quaisquer danos de transporte ou de superfície.
- As tubagens e a torneira têm que ser montadas, enxaguadas e verificadas de acordo com as normas em vigor.
- A prescrições de instalação válidas nos respetivos países devem ser respeitadas.

Dados Técnicos

Pressão de funcionamento: max. 1 MPa
 Pressão de func. recomendada: 0,1 - 0,5 MPa
 Pressão testada: 1,6 MPa
 (1 MPa = 10 bar = 147 PSI)
 Temperatura da água quente: max. 80 °C
 Temp. água quente recomendada: 65 °C
 Desinfecção térmica: max. 70 °C / 4 min

14146000 / 14466000 / 15447XXX / 31451000 / 31466000 / 31486000 / 31487000 / 31646000 / 31946000 / 32477000: Função anti-retorno e anti-vácuo

Este produto foi única e exclusivamente concebido para água potável!

Descrição do símbolo



Não utilizar silicone que contenha ácido acético!



Afinação (ver página 33)

Ajuste do limitador de água quente. Em combinação com um esquentador, não é recomendável o uso de um bloqueio de água quente.



Medidas (ver página 34)



Fluxograma

(ver página 35)

- ① Saída do chuveiro
- ② Saída da banheira



Funcionamento (ver página 41)



Manutenção (ver página 36)

14146000 / 14466000 / 15447XXX / 31451000 / 31466000 / 31486000 / 31487000 / 31646000 / 31946000 / 32477000: As válvulas anti-retorno devem ser verificadas regularmente de acordo com a DIN EN 1717 segundo os regulamentos nacionais ou regionais (pelo menos uma vez por ano).



Limpeza (consultar a seguinte brochura)



Peças de substituição (ver página 38)



Marca de controlo (ver página 48)

Falha	Causa	Solução
Misturadora perra	- Cartucho defeituoso, calcificado	- Substituir o cartucho
Misturadora a pingar	- Cartucho defeituoso	- Substituir o cartucho
Temperatura da água quente muito baixa, sem água fria. O esquentador dispara quando a água fria está seleccionada.	- O limitador de temperatura está incorrectamente colocado - Fluxo cruzado	- Regular o limitador de temperatura - Substituir o cartucho
Inversor não funciona	- Depósitos - Pressão da água muito baixa - Inversor defeituoso	- Limpar inversor / lubrificar vedantes em O - Aumentar a pressão da água - Substituir o inversor



Montagem ver página 31



Polski

Wskazówki bezpieczeństwa

- ⚠ Aby uniknąć zranień, takich jak zgniecenia czy przecięcia, podczas montażu należy nosić rękawice.
- ⚠ Prysznic może być używany tylko do kąpieli, higieny i czyszczenia ciała.
- ⚠ Znaczne różnice ciśnień na dopływach ciepłej i zimnej wody muszą zostać wyrównane.

Wskazówki montażowe

- Przed montażem należy skontrolować produkt pod kątem szkód transportowych. Po montażu nie widać żadnych szkód transportowych ani szkód na powierzchni.
- Przewody i armatura muszą być montowane, płukane i kontrolowane według obowiązujących norm.
- Należy przestrzegać wytycznych instalacyjnych obowiązujących w danym kraju.

Dane techniczne

Ciśnienie robocze:	maks. 1 MPa
Zalecane ciśnienie robocze:	0,1 - 0,5 MPa
Ciśnienie próbne:	1,6 MPa
(1 MPa = 10 bary = 147 PSI)	
Temperatura wody gorącej:	maks. 80 °C
Zalecana temperatura wody gorącej:	65 °C
Dezynfekcja termiczna:	maks. 70 °C / 4 min

14146000 / 14466000 / 15447XXX / 31451000 / 31466000 / 31486000 / 31487000 / 31646000 / 31946000 / 32477000: Zabezpieczony przed przepływem zwrotnym

Produkt przeznaczony wyłącznie do wody pitnej!

Opis symbolu



Nie stosować silikonów zawierających kwas octowy!



Ustawianie (patrz strona 33)

Ustawianie ogranicznika ciepłej wody. Używanie ogranicznika temperatury wody w połączeniu z przepływowym podgrzewaczem wody nie jest zalecane.

Wymiary (patrz strona 34)



Schemat przepływu

(patrz strona 35)

- ① Odpływ prysznica
- ② Odpływ wanny



Obsługa (patrz strona 41)



Konserwacja (patrz strona 36)

14146000 / 14466000 / 15447XXX / 31451000 / 31466000 / 31486000 / 31487000 / 31646000 / 31946000 / 32477000: Zawory zwrotne muszą być, według normy DIN EN 1717 na regionalnych warunkach, kontrolowane (przynajmniej raz w roku).



Czyszczenie (patrz dołączona broszura)



Części serwisowe

(patrz strona 38)



Znak jakości (patrz strona 48)

Usterka	Przyczyna	Pomoc
Uchwyt armatury pracuje z wysiłkiem	- Uszkodzony wkład, zakamieniony	- Wymiana wkładu
Armatura cieknie	- Uszkodzony wkład	- Wymiana wkładu
Za niska temperatura ciepłej wody, brak zimnej wody. Przepływowy podgrzewacz wody uruchamia się, gdy wybiera się zimną wodę.	- Niewłaściwe ustawienie ogranicznika ciepłej wody - Przepływ krzyżowy	- Ustawić ogranicznik ciepłej wody - Wymiana wkładu
Przełącznik nie funkcjonuje	- Osady - Zbyt niskie ciśnienie wody - Uszkodzony przełącznik	- Wyczyścić przełącznik / nasmarować o-ringi - Podnieść ciśnienie wody - Wymienić przełącznik



Montaż patrz strona 31



Bezpečnostní pokyny

- ⚠ Pro zabránění řezným zraněním a pohmožděninám je nutné při montáži nosit rukavice.
- ⚠ Produkt smí být používán pouze ke koupání a za účelem tělesné hygieny.
- ⚠ Je nutné vyrovnat velké rozdíly tlaku mezi přípoji studené a teplé vody.

Pokyny k montáži

- Před montáží je třeba produkt zkontrolovat, zda nebyl při transportu poškozen. Po zabudování nebudou uznány žádné škody způsobené transportem nebo poškození povrchu.
- Vedení a armatura musí být namontovány, propláchnuty a otestovány podle platných norem.
- Je třeba dodržovat montážní pravidla platné v dané zemi.

Technické údaje

Provozní tlak:	max. 1 MPa
Doporučený provozní tlak:	0,1 - 0,5 MPa
Zkušební tlak:	1,6 MPa
(1 MPa = 10 bar = 147 PSI)	
Teplota horké vody:	max. 80 °C
Doporučená teplota horké vody:	65 °C
Tepelná desinfekce:	max. 70 °C / 4 min

14146000 / 14466000 / 15447XXX / 31451000 / 31466000 / 31486000 / 31487000 / 31646000 / 31946000 / 32477000: Vlastní jištění proti zpětnému nasátí.

Výrobky Hansgrohe jsou vhodné pro přímý kontakt s pitnou vodou.

Popis symbolů



Nepoužívat silikon s obsahem kyseliny octové!



Nastavení (viz strana 33)

Nastavení omezovače teplé vody. Ve spojení s průtokovým ohřívačem se použití uzávěru teplé vody nedoporučuje.



Rozměry (viz strana 34)



Diagram průtoku

(viz strana 35)

① Odtok sprchy

② Odtok vany



Ovládání (viz strana 41)



Údržba (viz strana 36)

14146000 / 14466000 / 15447XXX / 31451000 / 31466000 / 31486000 / 31487000 / 31646000 / 31946000 / 32477000: Bezpečnostní zařízení musí být podle DIN EN 1717 pravidelně v souladu s národními nebo místními předpisy (DIN 1988) jednou ročně přezkoušena.



Čištění (viz příložená brožura)



Servisní díly (viz strana 38)



Zkušební značka (viz strana 48)

Porucha	Příčina	Odstranění
Armatura jde ztěžka	- Kartuše je vadná, zanesená vodním kamenem	- Kartuši vyměnit
Armatura odkapává	- Kartuše je vadná	- Kartuši vyměnit
nízká teplota teplé vody .žádá studená voda průtokový ohřívač naskočí, když se navolí studená voda	- Špatně nastavená zarážka pro teplou vodu	- Seřadit zarážku pro teplou vodu
Přepínač nefunguje	- Křížení toků	- Kartuši vyměnit
	- Usazeniny	- Vyčistit přepínač/promazat o-kroužky
	- příliš malý tlak vody	- zvýšit tlak vody
	- přepínač defektní	- Přepínač vyměnit



Montáž viz strana 31



Slovensky

Bezpečnostné pokyny

- ⚠ Pri montáži musíte nosiť rukavice, aby ste predišli pomliaždeninám a rezným poraneniam.
- ⚠ Produkt sa smie používať len na kúpanie a telesnú hygienu.
- ⚠ Veľké rozdiely v tlaku medzi prípojkami studenej a teplej vody musia byť vyrovnané.

Pokyny pre montáž

- Pred montážou musíte produkt skontrolovať, či nebol počas transportu poškodený. Po zabudovaní nebudú uznané žiadne škody spôsobené transportom alebo poškodenia povrchu.
- Ledningarna och blandaren måste monteras, spolagsigenom och kontrolleras enligt de gällande normerna.
- Je potrebné dodržiavať smernice o inštalácii, ktoré sú práve teraz platné v krajinách.

Technické údaje

Prevádzkový tlak:	max. 1 MPa
Doporučený prevádzkový tlak:	0,1 - 0,5 MPa
Skúšobný tlak:	1,6 MPa
(1 MPa = 10 bar = 147 PSI)	
Teplota teplej vody:	max. 80 °C
Doporučená teplota teplej vody:	65 °C
Termická dezinfekcia:	max. 70 °C / 4 min

14146000 / 14466000 / 15447XXX / 31451000 / 31466000 / 31486000 / 31487000 / 31646000 / 31946000 / 32477000: Vlastná poisťka proti spätnému nasatiu.

Výrobok je koncipovaný výhradne pre pitnú vodu!

Popis symbolov



Nepoužívať silikón s obsahom kyseliny octovej!



Nastavenie (viď strana 33)

Nastavenie obmedzenia teplej vody. V spojení s prietokovými ohrievačmi sa neodporúča použitie obmedzovača teplej vody.



Rozmery (viď strana 34)



Diagram prietoku
(viď strana 35)

- ① Odtok sprchy
- ② Odtok vane



Obsluha (viď strana 41)



Údržba (viď strana 36)

14146000 / 14466000 / 15447XXX / 31451000 / 31466000 / 31486000 / 31487000 / 31646000 / 31946000 / 32477000: Bezpečnostné zariadenie musí byť podľa DIN EN 1717 pravidelne raz za rok preskúšané v súlade s národnými alebo miestnymi predpismi (DIN 1988).



Čistenie (nájdete v priloženej brožúre)



Servisné diely (viď strana 38)



Osvedčenie o skúške (viď strana 48)

Porucha	Príčina	Pomoc
Armatúra "chodi" ťažko	- Kartúša je poškodená, vápenaté usadeniny	- Vymeniť kartúšu
Z armatúry kvapká voda	- Kartúša je poškodená	- Vymeniť kartúšu
Málo teplá voda, žiadna studená voda, prietokový ohrievač naskočí, keď sa navolí studená voda.	- Nesprávne nastavená zarážka na teplú vodu - Križenie tokov	- Nastavenie zarážky na teplú vodu - Vymeniť kartúšu
Prepínač nefunguje	- Usadeniny - Príliš malý tlak vody - Prepínač defektný	- Vyčistiť prepínač / namazať O krúžky - Zvýšiť tlak vody - Prepínač vymeniť



Montáž viď strana 31



⚠ 安全技巧

- △ 装配时为避免挤压和切割受伤，必须戴上手套。
- △ 淋浴系统只允许作为洗浴、卫生和洁身之用。
- △ 冷热水管间过大的压力差必须予以平衡。

安装提示

- 安装前必须检查产品是否受到运输损害。安装后将不认可运输损害或表面损伤。
- 管道和阀门必须根据通用标准进行安装、冲洗和检查。
- 请遵守当地国家现行的安装规定。

技术参数

工作压强: 最大 1 MPa
 推荐工作压强: 0,1 – 0,5 MPa
 测试压强: 1,6 MPa
 (1 MPa = 10 bar = 147 PSI)

热水温度: 最大 80°C
 推荐热水温度: 65°C
 热力消毒: 最大 70°C / 4 分钟

14146000 / 14466000 / 15447XXX / 31451000
 / 31466000 / 31486000 / 31487000 /
 31646000 / 31946000 / 32477000: 自动防止
 回流

该产品专为饮用水设计！

符号说明



请勿使用含有乙酸的硅！



调节 (参见第页 33)

热水温度调节。如果使用即热式喷头，则不建议安装热水阀门。



大小 (参见第页 34)



流量示意图
 (参见第页 35)

- ① 莲蓬头盆管
- ② 面盆盆管



操作 (参见第页 41)



保养 (参见第页 36)

14146000 / 14466000 / 15447XXX /
 31451000 / 31466000 / 31486000 /
 31487000 / 31646000 / 31946000
 / 32477000: 必须根据DIN EN 1717
 要求并根据国家或地方规定定期 (DIN
 1988规定为一年一次) 检查安全装置
 的功能。



清洗 (附有小手册)



备用零件 (参见第页 38)



检验标记 (参见第页 48)

问题	原因	补救
龙头不灵活	- 阀芯损坏, 结垢	- 更换阀芯
龙头滴水	- 阀芯损坏	- 更换阀芯
热水温度过低, 没有冷水。选择冷水时, 热水器启动。	- 热水控制器设置错误 - 交叉流动	- 设置热水控制器 - 更换阀芯
分流器不工作	- 沉积物 - 水压过低 - 分流器损坏	- 清洁分流器 / 给O形环上油 - 增加水压 - 更换分流器



安装 参见第页 31



Русский



Указания по технике безопасности

- Во время монтажа следует надеть перчатки во избежание прищемления и порезов.
- Изделие разрешается использовать только в гигиенических целях: для принятия ванны и личной гигиены.
- донного клапа. Перед установкой смесителя необходимо регулировочными кранами выровнять авление холодной и горячей воды при помощи вентмлей регулирующих подачу воды в квартиру.

Указания по монтажу

- Перед монтажом следует проверить изделие на предмет повреждений при перевозке. После монтажа претензии о возмещении ущерба за повреждения при перевозке или повреждения поверхностей не принимаются.
- Трубы и арматура должны быть установлены, промыты и проверены в соответствии с действующими нормами.
- Необходимо соблюдать требования по монтажу, действующие в соответствующих странах.

Технические данные

Рабочее давление: не более. 1 МПа
 Рекомендуемое рабочее давление: 0,1 - 0,5 МПа
 Давлении: 1,6 МПа
 (1 МПа = 10 bar = 147 PSI)
 Температура горячей воды: не более. 80 °C
 Рекомендуемая темп. гор. воды: 65 °C
 Термическая дезинфекция: не более. 70 °C / 4 мин

14146000 / 14466000 / 15447XXX / 31451000 / 31466000 / 31486000 / 31487000 / 31646000 / 31946000 / 32477000: укомплектован клапаном обратного тока воды

Изделие предназначено исключительно для питьевой воды!

Неисправность	Причина	Устранение неисправности
Арматура работает с усилием	- Картридж неисправен, засорение накипью	- Замените картридж
Арматура протекает	- Картридж неисправен	- Замените картридж
Слишком низкая температура горячей воды. Проточный нагреватель запускается при выборе холодной воды.	- Ограничение горячей воды отрегулировано неправильно	- Отрегулируйте ограничение горячей воды
Переключатель не работает	- Перекрестный поток - отложения	- Замените картридж - очистите переключатель / смажьте консистентной смазкой кольца круглого сечения
	- Слишком малое давление воды	- Увеличьте давление воды
	- Переключатель неисправен	- Замените переключатель

Описание символов



Не применяйте силикон, содержащий уксусную кислоту.



Подгонка (см. стр. 33)

Регулировка ограничителя горячей воды. В сочетании с проточными нагревателями не рекомендуется использовать блокировку воды.



Размеры (см. стр. 34)



Схема потока

(см. стр. 35)

- ① Отвод душа
- ② Отвод ванны



Эксплуатация (см. стр. 41)



Техническое обслуживание (см. стр. 36)

14146000 / 14466000 / 15447XXX / 31451000 / 31466000 / 31486000 / 31487000 / 31646000 / 31946000 / 32477000: Прокладка отвода должна осуществляться без нагрузки!



Очистка (см прилагаемая брошюра)



Комплект (см. стр. 38)



Знак технического контроля (см. стр. 48)





Biztonsági utasítások

- ⚠ A szerelésnél a zúzódások és vágási sérülések elkerülése érdekében kesztyűt kell viselni.
- ⚠ A terméket csak fürdéshez, mosakodáshoz, és egészségügyi tisztálkodáshoz szabad használni.
- ⚠ A hidegvíz- és a melegvíz-csatlakozások közötti nagy nyomáskülönbséget kikell egyenlíteni!

Szerelési utasítások

- A szerelés előtt ellenőrizni kell, hogy a terméknek nincs-e szállítási sérülése. Beépítés után a szállítási- vagy felületi sérüléseket nem ismerik el.
- A vezetékeket és a csaptelepet az érvényes szabványoknak megfelelően kell felszerelni, öblíteni és ellenőrizni
- Az egyes országokban érvényes installációs irányelveket be kell tartani.

Műszaki adatok

Üzemi nyomás:	max. 1 MPa
Ajánlott üzemi nyomás:	0,1 - 0,5 MPa
Nyomáspróba:	1,6 MPa
(1 MPa = 10 bar = 147 PSI)	
Forróvíz hőmérséklet:	max. 80 °C
Forróvíz javasolt hőmérséklete:	65 °C
Termikus fertőtlenítés:	max. 70 °C / 4 perc

14146000 / 14466000 / 15447XXX / 31451000 /
31466000 / 31486000 / 31487000 / 31646000 /
31946000 / 32477000: Visszafolyás gátlóval

A terméket kizárólag ivóvízhez tervezték!

Szimbólumok leírása



Ne használjon ecetsavtartalmú szilikon!



Beállítás (lásd a oldalon 33)

A meleg víz korlátozás beállítása. Átfolyós vízmelegítőknél meleg víz korlátozó használata nem ajánlott.



Méretet (lásd a oldalon 34)



Átfolyási diagramm
(lásd a oldalon 35)

- ① Zuhany lefolyója
- ② Kád lefolyója



Használat (lásd a oldalon 41)



Karbantartás (lásd a oldalon 36)

14146000 / 14466000 / 15447XXX /
31451000 / 31466000 / 31486000 /
31487000 / 31646000 / 31946000 /
32477000: A biztonsági berendezések működését a DIN EN 1717 szerint rendszeresen, a nemzeti vagy helyi előírásoknak megfelelően (DIN 1988 évente egyszer) ellenőrizni kell.



Tisztítás (lásd a mellékelt brosúrát)



Tartozékok (lásd a oldalon 38)



Vizsgajel (lásd a oldalon 48)

Hiba	Ok	Megoldás
Nehezen nyitható a csap.	- A kerámiabetét meghibásodott, elvízkövesedett.	- A kerámiabetétet ki kell cserélni.
Csöpög a csap.	- A kerámiabetét meghibásodott.	- A kerámiabetétet ki kell cserélni.
Túl alacsony melegvíz hőmérséklet, nincs hidegvíz. A hidegvíz kiválasztásakor beindul az átfolyós melegítő.	- A melegvíz szabályozó rosszul van beállítva. - Kereszfolyás	- A melegvíz szabályozót újra be kell állítani. - A kerámiabetétet ki kell cserélni.
Az átállítás nem működik	- Lerakódások - Túl kicsi víznyomás - A kádváltó szelep hibás	- Váltószelepet tisztítani / O-gyűrűket zsírozni - Növelje a víznyomást - Az átállító cseréje



Szerelés lásd a oldalon 31



Suomi

Turvallisuusohjeet

- △ Asennuksessa on käytettävä käsineitä puristumien ja viiltojen aiheuttamien tapaturmien estämiseksi.
- △ Suihkujärjestelmää saa käyttää ainoastaan kylpy-, hygienia- ja puhdistustarkoituksiin.
- △ Suuret paine-erot kylmä- ja kuumavesiliitännöiden välillä on tasattava.

Asennusohjeet

- Ennen asennusta on tarkastettava tuotteen mahdolliset kuljetusvahingot. Asennuksen jälkeen kuljetus- ja pintavaurioita ei hyväksytä.
- Putket ja hana on asennettava, huuhdeltava ja tarkastettava voimassa olevien standardien mukaisesti.
- Jokaisessa maassa on noudatettava siellä päteviä asennusohjeita.

Tekniset tiedot

Käyttöpaine:	maks. 1 MPa
Suosittelut käyttöpaine:	0,1 - 0,5 MPa
Koestuspaine:	1,6 MPa
(1 MPa = 10 bar = 147 PSI)	
Kuuman veden lämpötila:	maks. 80 °C
Kuuman veden suosituslämpötila:	65 °C
Lämpödesinfektio:	maks. 70 °C / 4 min

14146000 / 14466000 / 15447XXX / 31451000 / 31466000 / 31486000 / 31487000 / 31646000 / 31946000 / 32477000: Estää itsestään paluuvirtauksen

Tuote on suunniteltu käytettäväksi ainoastaan juomaveden kanssa!

Merkin kuvaus



Älä käytä etikkahappopitoista silikonia!



Säätö (katso sivu 33)

Lämpötilan rajoittimen säätäminen. Emme suosittele käyttämään lämpötilan rajoitinta vedenlämmittimen (läpivirtauskuumennin) yhteydessä.

Mitat (katso sivu 34)



Virtausdiagrammi

(katso sivu 35)

- ① Suihkun lähtö
- ② Ammeen lähtö



Käyttö (katso sivu 41)



Huolto (katso sivu 36)

14146000 / 14466000 / 15447XXX / 31451000 / 31466000 / 31486000 / 31487000 / 31646000 / 31946000 / 32477000: Turvalaitteiden toiminta on tarkastettava DIN EN 1717:n mukaisesti säännöllisin väliajoin kansallisten ja paikallisten määräysten mukaisesti (DIN 1988: kerran vuodessa).



Puhdistus (katso oheinen esite)



Varaosat (katso sivu 38)



Koestusmerkki (katso sivu 48)

Häiriö	Syy	Toimenpide
Hana on raskaskäyttöinen	- Patruuna rikki, kalkkikerrostumia	- Vaihda patruuna
Hanasta tippuu vettä	- Patruuna rikki	- Vaihda patruuna
Lämminveden lämpötila liian alhainen, ei kylmää vettä. Läpivirtauskuumennin käynnistyy kylmää vettä otettaessa.	- Lämminveden rajoitin väärin säädetty	- Säädä lämminveden rajoitin
Valitsin ei toimi	- Ristiinvirtaus	- Vaihda patruuna
	- kerrostumia	- Vaihtimen puhdistus / O-renkaiden rasvaus
	- Liian matala vedenpaine	- Lisää vedenpainetta
	- Valitsin rikki	- Vaihda valitsin



Asennus katso sivu 31



Säkerhetsanvisningar

- ⚠ Handskar ska bäras under monteringsarbetet så att man kan undvika kläm- och skärskadorna.
- ⚠ Produkten får bara användas till kroppshygien med bad och dusch.
- ⚠ Stora tryckskillnader mellan anslutningarna för varmt och kallt vatten måste utjämnas.

Monteringsanvisningar

- Det måste undersökas om produkten har transportskador innan den monteras. Efter monteringen accepteras inga transport- eller ytskiktsskador.
- Ledningarna och blandaren måste monteras, spolas igenom och kontrolleras enligt de gällande normerna.
- De installationsriktlinjer som gäller i länderna ska följas.

Tekniska data

Driftstryck:	max. 1 MPa
Rek. driftstryck:	0,1 - 0,5 MPa
Tryck vid provtryckning: (1 MPa = 10 bar = 147 PSI)	1,6 MPa
Varmvattentemperatur:	max. 80 °C
Rek. varmvattentemp.:	65 °C
Termisk desinfektion:	max. 70 °C / 4 min

14146000 / 14466000 / 15447XXX / 31451000 /
31466000 / 31486000 / 31487000 / 31646000 /
31946000 / 32477000: Självspärr mot återflöde

Produkten är enbart avsedd för dricksvatten!

Symbolförklaring



Använd inte silikon som innehåller ättiksyra!



Justering (se sidan 33)

Ställa in varmvattenregleringen. Tillsammans med varmvattenberedare rekommenderas inte en varmvattenspärr.



Måtten (se sidan 34)



Flödesschema

(se sidan 35)

- ① Avlopp dusch
- ② Avlopp kar



Hantering (se sidan 41)



Skötsel (se sidan 36)

14146000 / 14466000 / 15447XXX /
31451000 / 31466000 / 31486000 /
31487000 / 31646000 / 31946000 /
32477000: Enligt DIN EN 1717 måste
säkerhetsanordningarnas funktion kontrol-
leras regelbundet och i överensstämmelse
med nationella eller regionala bestämmelser
(DIN 1988 en gång per år).



Rengöring (se den medföljande broschyren)



Reservdelar (se sidan 38)



Testsigill (se sidan 48)

Störning	Orsak	Åtgärd
Blandare är trög	- Patron defekt, förkalkad	- Byt ut patron
Blandare droppar	- Patron defekt	- Byt ut patron
För låg varmvattentemperatur, inget kallvatten. Varmvattenberedaren slår på när kallvatten väljs.	- Varmvattenreglering felaktigt inställd - Korsflöde	- Ställ in varmvattenreglering - Byt ut patron
Omkopplare fungerar inte	- Avlagringar - För lågt vattentryck - Omkopplare defekt	- Rengör omkastare / smörj O-ringar - Öka vattentrycket - Byt ut omkopplare



Montering se sidan 31



Lietuviškai

Saugumo technikos nurodymai

- ⚠ Apsaugai nuo užspaudimo ir įsipjovimo montavimo metu mūvėkite pirštines.
- ⚠ Gaminys turi būti naudojamas tik maudymuisi, kūno higienai ir švarai palaikyti.
- ⚠ Turi būti išlyginti šalto ir karšto slėgio nelygumai.

Montavimo instrukcija

- Prieš montuojant būtina patikrinti, ar gaminys nebuvo pažeistas transportavimo metu. Sumontavus pretenzijos dėl transportavimo ir paviršiaus pažeidimų nepriimamos.
- Vamzdžiai ir sujungimai turi būti montuojami, plaunami ir tikrinami pagal galiojančias normas.
- Laikykitės atitinkamoje šalyje galiojančių direktyvų dėl įrengimo.

Techniniai duomenys

Darbinis slėgis: ne daugiau kaip 1 MPa
 Rekomenduojamas slėgis: 0,1 - 0,5 MPa
 Bandomasis slėgis: 1,6 MPa
 (1 MPa = 10 barų = 147 PSI)
 Karšto vandens temperatūra: ne daugiau kaip 80 °C
 Rekomenduojama karšto vandens temperatūra: 65 °C
 Terminis dezinfekavimas: ne daugiau kaip 70 °C / 4 min

14146000 / 14466000 / 15447XXX / 31451000 /
 31466000 / 31486000 / 31487000 / 31646000 /
 31946000 / 32477000: Su atbuliniu vožtuvu

Produktas skirtas tik geriamajam vandeniui!

Simbolio aprašymas



Nenaudokite silikono, kurio sudėtyje yra acto rūgšties!



Reguliavimas (žr. psl. 33)

Karšto vandens ribojimas. Kartu su cirkuliaciniais šildytuvais nerekomenduojama naudoti karšto vandens blokavimo įtaisų.



Išmatavimai (žr. psl. 34)



Pralaidumo diagrama

(žr. psl. 35)

- ① Dušo išleidimas
- ② Vonios išleidimas



Eksplotacija (žr. psl. 41)



Techninis aptarnavimas (žr. psl. 36)

14146000 / 14466000 / 15447XXX /
 31451000 / 31466000 / 31486000 /
 31487000 / 31646000 / 31946000 /
 32477000: Pagal DIN EN 1717 ir nacionalines arba regionines direktyvas reikia reguliariai tikrinti saugos įrangos veikimą (pagal DIN 1988 - kartą per metus).



Valymas (žr. pridedamoje brošiūroje)



Atsarginės dalys (žr. psl. 38)



Bandyimo pažyma (žr. psl. 48)

Gedimas	Priežastis	Priemonė
Sunkiai sukiojama rankenėlė	- Kasetė pažeista, užkalkėjusi	- Pakeisti kasetę
Maišytuvas praleidžia vandenį	- Kasetė pažeista	- Pakeisti kasetę
Per maža karšto vandens temperatūra, nėra šalto vandens. Momentinis pašildytojas pradeda veikti, kai naudojamas šalta vanduo	- Neteisingai nustatytas karšto vandens ribotuvas - Kryžminė srovė	- Nustatyti karšto vandens ribotuvą - Pakeisti kasetę
Perjungėjas nefunkcionuoja	- Apnašos - Nepakankamas vandens spaudimas - Pažeistas perjungėjas	- Išvalykite atsukimą/-sutepkite O-žiedus - Pakelti vandens spaudimą - Pakeisti perjungėją



Montavimas žr. psl. 31



Sigurnosne upute

- ⚠ Prilikom montaže se radi sprječavanja prignječenja i posjekotina moraju nositi rukavice.
- ⚠ Proizvod se smije primjenjivati samo za kupanje, tuširanje i osobnu higijenu.
- ⚠ Velika razlika u pritisku između vruće i hladne vode mora biti izbalansirana.

Upute za montažu

- Prije montaže mora se provjeriti je li proizvod oštećen prilikom transporta. Nakon ugradnje se ne priznaju nikakve reklamacije koje se odnose na površinska i transportna oštećenja.
- Cijevi i armatura moraju biti postavljeni, isprani i testirani prema važećim normama.
- Obvezno se moraju uvažiti propisi o instalacijama koji vrijede u dotičnoj zemlji.

Tehnički podatci

Najveći dopušteni tlak:	tlak 1 MPa
Preporučeni tlak:	0,1 - 0,5 MPa
Probni tlak:	1,6 MPa
(1 MPa = 10 bar = 147 PSI)	
Temperatura vruće vode:	tlak 80 °C
Preporučena temperatura vruće vode:	65 °C
Termička dezinfekcija:	tlak 70 °C / 4 min

14146000 / 14466000 / 15447XXX / 31451000 / 31466000 / 31486000 / 31487000 / 31646000 / 31946000 / 32477000: Funkcije samo-čišćenja

Proizvod je koncipiran isključivo za pitku vodu!

Opis simbola



Nemojte koristiti silikon koji sadrži octenu kiselinu!



Regulacija (pogledaj stranicu 33)

Namještanje limitera tople vode. U kombinaciji s protočnim bojlerima nije preporučljiva primjena sustava za blokiranje dotoka tople vode.



Mjere (pogledaj stranicu 34)

Dijagram protoka (pogledaj stranicu 35)

- ① Ogranak tuš
- ② Ogranak kada



Upotreba (pogledaj stranicu 41)



Održavanje (pogledaj stranicu 36)

14146000 / 14466000 / 15447XXX / 31451000 / 31466000 / 31486000 / 31487000 / 31646000 / 31946000 / 32477000: Ispravno funkcioniranje sigurnosnih elemenata se mora redovito provjeravati prema standardu DIN EN 1717 i sukladno važećim nacionalnim ili regionalnim propisima (DIN 1988 jednom godišnje).



Čišćenje (se u priloženoj brošuri)



Rezervni dijelovi (pogledaj stranicu 38)



Oznaka testiranja (pogledaj stranicu 48)

Greška	Uzrok	Otklanjanje
Ručica se zaglavila	- Neispravan uložak - Taloženje kamenca	- Zamijenite uložak
Slavina kaplje	- Neispravan uložak	- Zamijenite uložak
Preniska temperatura vruće vode, nedostatak hladne vode. Protočni bojler se pali pri podešenoj funkciji za protok hladne vode	- Limiter vruće vode nije dobro podešen - Križni tok vode	- Podesite limiter vruće vode - Zamijenite uložak
Selektor ne radi	- Naslage - Prenizak tlak vode - Selektor je neispravan	- Čišćenje selektora i podmazivanje O-prstenova - Povećajte tlak vode - Zamijenite selektor



Sastavljanje pogledaj stranicu 31



Türkçe

Güvenlik uyarıları

- ⚠ Montaj esnasında ezilme ve kesilme gibi yaralanmaları önlemek için eldiven kullanılmalıdır.
- ⚠ Duş sistemi yalnızca banyo, hijyen ve beden temizliği amaçları doğrultusunda kullanılabilir.
- ⚠ Sıcak ve soğuk su bağlantıları arasında büyük basınç farklılıkları varsa, bu basınç farklılıklarının dengelenmesi gerekir.

Montaj açıklamaları

- Montaj işleminden önce ürün nakliye hasarları yönünden kontrol edilmelidir. Montaj işleminden sonra nakliye veya yüzey hasarları için sorumluluk üstlenilmemektedir.
- Boruların ve armatürün montajı, yıkanması ve kontrolü geçerli normlara göre yapılmalıdır.
- Ülkelerde geçerli kurulum yönetmeliklerine riayet edilmelidir.

Teknik bilgiler

İşletme basıncı: azami 1 MPa
Tavsiye edilen işletme basıncı: 0,1 - 0,5 MPa
Kontrol basıncı: 1,6 MPa
(1 MPa = 10 bar = 147 PSI)
Sıcak su sıcaklığı: azami 80 °C
Tavsiye edilen su ısı: 65 °C
Termik dezenfeksiyon: azami 70 °C / 4 dak

14146000 / 14466000 / 15447XXX / 31451000 /
31466000 / 31486000 / 31487000 / 31646000 /
31946000 / 32477000: Geri emme önleyici

Ürün sadece şebeke suyu için tasarlanmıştır!

Simge açıklaması



Asetik asit içeren silikon kullanmayın!



Ayarlama (bakınız sayfa 33)

Sıcak su sınırlamasının ayarlanması. Sıcak su kilidinin sürekli ısıtıcıyla kullanılması tavsiye edilmez.



Ölçüleri (bakınız sayfa 34)



Akış diyagramı (bakınız sayfa 35)

- ① Su püskürtücü çıkışı
- ② Tekne çıkışı



Kullanımı (bakınız sayfa 41)



Bakım (bakınız sayfa 36)

14146000 / 14466000 / 15447XXX /
31451000 / 31466000 / 31486000 /
31487000 / 31646000 / 31946000 /
32477000: Emniyet tertibatları DIN EN
1717 uyarınca düzenli olarak ulusal veya
bölgesel yönetmeliklere göre (DIN 1988
uyarınca yılda bir kez), işlev yönünden
kontrol edilmelidir.



Temizleme (birlikte verilen broşür)



Yedek Parçalar (bakınız sayfa 38)



Kontrol işareti (bakınız sayfa 48)

arıza	sebebi	yardım
Batarya kullanımı ağırlaşıyor	- Kartuş Bozulmuş ve kireçlenmiş olabilir	- Kartuşu değiştirin
Batarya su damlatıyor	- Kartuş bozuk olabilir	- Kartuşu değiştirin
Sıcak su sıcaklığı çok düşük, soğuk su yok. Soğuk su seçilince şofben çalışmaya başlıyor.	- Isı limitleyici düzgün çalışmıyor	- Isı limitleyiciyi yeniden ayarlayın
	- Çapraz akış	- Kartuşu değiştirin
Divertör çalışmıyor	- Çökelmeler	- Dönüştürücüyü temizleme / O ringleri yağlama
	- Su basıncı düşük	- Su basıncını artırın
	- Divertör arızalı	- Divertörü değiştirin



Montajı bakınız sayfa 31



Instrucțiuni de siguranță

- ⚠ La montare utilizați mănuși pentru evitarea contuziunilor și tăierii mâinilor.
- ⚠ Sistemul de duș poate fi utilizat doar pentru spălarea, menținerea igienei și curățarea corpului.
- ⚠ Diferențele de presiune mari între alimentarea cu apă rece și apă caldă trebuie echilibrate.

Instrucțiuni de montare

- Înainte de instalare verificați, dacă produsul prezintă deteriorări de transport. După instalare garanția nu acoperă deteriorările de transport și cele de suprafață.
- Conductele și bateriile trebuie montate, spălate și verificate conform normelor în vigoare.
- Respectați reglementările referitoare la instalare valabile în țara respectivă.

Date tehnice

Presiune de funcționare:	max. 1 MPa
Presiune de funcționare recomandată:	0,1 - 0,5 MPa
Presiune de verificare:	1,6 MPa
(1 MPa = 10 bar = 147 PSI)	
Temperatura apei calde:	max. 80 °C
Temperatura recomandată a apei calde:	65 °C
Dezinfecție termică:	max. 70 °C / 4 min

14146000 / 14466000 / 15447XXX / 31451000 / 31466000 / 31486000 / 31487000 / 31646000 / 31946000 / 32477000: Asigurat contra scurgere înapoi

Produsul este destinat exclusiv pentru apă potabilă.

Descrierea simbolurilor



Nu utilizați silicon cu conținut de acid acetic!



Reglare (vezi pag. 33)

Reglarea limitatorului de apă caldă. Nu se recomandă folosirea unui limitator de apă caldă în combinație cu un boiler instant.



Dimensiuni (vezi pag. 34)



Diagrama de debit

(vezi pag. 35)

- ① Orificiu de scurgere duș
- ② Orificiu de scurgere vană



Utilizare (vezi pag. 41)



Întreținere (vezi pag. 36)

14146000 / 14466000 / 15447XXX / 31451000 / 31466000 / 31486000 / 31487000 / 31646000 / 31946000 / 32477000: Dispozitiile de siguranță trebuie verificate regulat conform DIN EN 1717 și în conformitate cu reglementările naționale și regionale (o dată pe an conform DIN 1988).



Curățare (vezi broșura alăturată)



Piese de schimb (vezi pag. 38)



Certificat de testare (vezi pag. 48)

Deranjament	Cauza	Măsuri de remediere
Bateria se mișcă dificil	- Cartuș defect din cauza depunerilor de calcar	- Schimbați cartușul.
Bateria picură	- Cartuș defect	- Schimbați cartușul.
Temperatura apei este prea mică, nu este apă rece. Boilerul instant pornește când se dă drumul la apa rece	- Limitarea temperaturii apei calde setată incorect. - Curgere încrucișată (apa rece în intră în conducta de apă caldă și invers)	- Setați limitarea temperaturii apei calde. - Schimbați cartușul.
Cartușul nu funcționează.	- Depuneri - Presiune apă prea mică - Cartuș defect	- Curățați inversorul / ungeți inelele O - Măriți presiunea de apă - Schimbați cartușul.



Montare vezi pag. 31



Ελληνικά

Υποδείξεις ασφαλείας

- ⚠ Για να αποφύγετε τραυματισμούς κατά τη συναρμολόγηση πρέπει να φοράτε γάντια.
- ⚠ Το προϊόν επιτρέπεται να χρησιμοποιείται μόνο σαν μέσο λουτρού, υγιεινής και καθαρισμού του σώματος.
- ⚠ Οι διαφορές της πίεσης μεταξύ της σύνδεσης κρύου και ζεστού νερού θα πρέπει να αντισταθμίζονται.

Οδηγίες συναρμολόγησης

- Πριν τη συναρμολόγηση πρέπει να εξεταστεί το προϊόν για ζημιές μεταφοράς. Μετά την εγκατάσταση δεν αναγνωρίζονται ζημιές από τη μεταφορά ή επιφανειακές ζημιές.
- Οι σωλήνες και η μπαταρία πρέπει να τοποθετηθούν σύμφωνα με τα ισχύοντα πρότυπα, να τεθούν υπό πίεση και να δοκιμαστούν.
- Θα πρέπει να τηρούνται οι οδηγίες εγκατάστασης που ισχύουν σε κάθε κράτος.

Τεχνικά Χαρακτηριστικά

Λειτουργία πίεσης: έως 1 MPa
 Συνιστώμενη λειτουργία πίεσης: 0,1 - 0,5 MPa
 Πίεση ελέγχου: 1,6 MPa
 (1 MPa = 10 bar = 147 PSI)
 Θερμοκρασία ζεστού νερού: έως 80 °C
 Συνιστώμενη θερμοκρασία ζεστού νερού: 65 °C
 Θερμική απολύμανση: έως 70 °C / 4 min

14146000 / 14466000 / 15447XXX / 31451000 / 31466000 / 31486000 / 31487000 / 31646000 / 31946000 / 32477000: Περιλαμβάνει βαλβίδα αντεπιστροφής.

Το προϊόν έχει σχεδιαστεί αποκλειστικά για πόσιμο νερό!

Περιγραφή συμβόλων



Μην χρησιμοποιείτε σιλικόνη που περιέχει οξικό οξύ!



Ρύθμιση (βλ. Σελίδα 33)

Ρύθμιση του δοσομετρητή ζεστού νερού. Δεν συνιστάται η διάταξη φραγής ζεστού νερού σε συνδυασμό με ταχυθερμοσίφωνα.



Διαστάσεις (βλ. Σελίδα 34)



Διάγραμμα ροής (βλ. Σελίδα 35)

- ① Εξοδος ντους
- ② Εξοδος μπανιέρας



Χειρισμός (βλ. Σελίδα 41)



Συντήρηση (βλ. Σελίδα 36)

14146000 / 14466000 / 15447XXX / 31451000 / 31466000 / 31486000 / 31487000 / 31646000 / 31946000 / 32477000: Οι διατάξεις ασφαλείας πρέπει να ελέγχονται σύμφωνα με το DIN EN 1717 τακτικά σύμφωνα με τις εθνικές ή τοπικές διατάξεις (DIN 1988 μία φορά τον χρόνο) ως προς τη λειτουργία τους.



Καθαρισμός (βλ. συνημμένο φυλλάδιο)



Ανταλλακτικά (βλ. Σελίδα 38)



Σήμα ελέγχου (βλ. Σελίδα 48)

Βλάβη	Αιτία	Διόρθωση
Σκληρή μπαταρία (μείκτης)	- Ελαττωματικό φυσιγγίο, άλατα	- Αλλαγή φυσιγγίου
Η μπαταρία στάζει	- Ελαττωματικό φυσιγγίο	- Αλλαγή φυσιγγίου
Χαμηλή θερμοκρασία ζεστού νερού, καθόλου κρύο νερό. Ο ταχυθερμοσίφωνα ενεργοποιείται, όταν επιλέγεται το κρύο νερό.	- Λάθος ρύθμιση της περιοριστικής διάταξης ζεστού νερού - Σταυροειδής ροή	- Ρυθμίστε την περιοριστική διάταξη του ζεστού νερού - Αλλαγή φυσιγγίου
Ο διακόπτης επιλογής δεν λειτουργεί	- Άλατα - Ανεπαρκής πίεση νερού - Βλάβη στο διακόπτη επιλογής	- Καθαρίστε τον ρυθμιστή νερού / λιπάνετε τους στεγανωτικούς δακτυλίους - Αυξήστε την πίεση του νερού - Αλλάξτε το διακόπτη επιλογής



Συναρμολόγηση βλ. Σελίδα 31



Varnostna opozorila

- ⚠ Pri montaži je treba nositi rokavice, da se preprečijo poškodbe zaradi zmečkanja ali urezov.
- ⚠ Ta izdelek se sme uporabljati le z namenom umivanja, vzdrževanja higiene in telesne nege.
- ⚠ Velike razlike v tlaku med priključkom za mrzlo in priključkom za toplo vodo je potrebno izravnati.

Navodila za montažo

- Pred montažo je treba izdelek preveriti glede morebitnih transportnih poškodb. Po vgradnji transportne ali površinske poškodbe ne bodo več priznane.
- Cevi in armaturo je treba montirati, izprati in preveriti po veljavnih standardih.
- Upoštevati je treba pravilnike o inštalacijah, ki veljajo v posamezni državi.

Tehnični podatki

Delovni tlak:	maks. 1 MPa
Priporočeni delovni tlak:	0,1 - 0,5 MPa
Preskusni tlak:	1,6 MPa
(1 MPa = 10 bar = 147 PSI)	
Temperatura tople vode:	maks. 80 °C
Priporočena temperatura tople vode:	65 °C
Termična dezinfekcija:	maks. 70 °C / 4 min

14146000 / 14466000 / 15447XXX / 31451000 / 31466000 / 31486000 / 31487000 / 31646000 / 31946000 / 32477000: Zaščita proti povratnemu toku

Proizvod je zasnovan izključno za sanitarno vodo!

Opis simbola



Ne smete uporabiti silikona, ki vsebuje ocatno kislino!



Justiranje (glejte stran 33)

Nastavitev omejevalnika tople vode. V povezavi s pretočnimi grelniki uporaba zapore tople vode ni priporočljiva.



Mere (glejte stran 34)



Diagram pretoka (glejte stran 35)

- ① Odvod prhe
- ② Odvod banje



Upravljanje (glejte stran 41)



Vzdrževanje (glejte stran 36)

14146000 / 14466000 / 15447XXX / 31451000 / 31466000 / 31486000 / 31487000 / 31646000 / 31946000 / 32477000: Funkcije varnostnih priprav je treba po DIN EN 1717 redno preverjati v skladu z nacionalnimi ali regionalnimi predpisi (DIN 1988 enkrat letno).



Čiščenje (glejte priloženi brošuri)



Rezervni deli (glejte stran 38)



Preskusni znak (glejte stran 48)

Napaka	Vzrok	Pomoč
Težko premikanje armature	- Pokvarjen vložek, poapneno	- Zamenjajte vložek
Iz armature kaplja	- Pokvarjen vložek	- Zamenjajte vložek
Prenizka temperatura tople vode, ni mrzle vode. Pretočni grelnik se sproži, kadar izberete mrzlo vodo.	- Omejevalnik tople vode ni pravilno nastavljen	- Nastavite omejevalnik tople vode
Preklopnik ne deluje	- Križni tok	- Zamenjajte vložek
	- Obloge	- Očistite premičnik / namastite obročno tesnilo
	- Prenizek vodni tlak	- Povečajte vodni tlak
	- Preklopnik je pokvarjen	- Zamenjajte preklopnik



Montaža glejte stran 31



Estonia

Ohutusjuhised

- △ Kandke paigaldamisel muljumis- ja löikevigastuste vältimiseks kindaid.
- △ Toodet tohib kasutada ainult pesemis-, hügieeni- ja kehapihustamiseesmärkidel.
- △ Kui külma ja kuumu vee ühenduste surve on väga erinev, tuleb need tasakaalustada.

Paigaldamisjuhised

- Enne paigaldamist tuleb toodet kontrollida transpordikahjustuste osas. Pärast paigaldamist ei tunnustata enam transpordi- või pinnakahjustuste kaebuseid.
- Voolikute ja segisti paigaldamisel, loputamisel ja kontrollimisel tuleb lähtuda kehtivatest normatiividest.
- Vastavas riigis kehtivaid paigalduseeskirju tuleb järgida.

Tehnilised andmed

Töörõhk	maks. 1 MPa
Soovitav töörõhk:	0,1 - 0,5 MPa
Kontrollsurve:	1,6 MPa
(1 MPa = 10 baari = 147 PSI)	
Kuumu vee temperatuur:	maks. 80 °C
Soovitav kuumu vee temperatuur:	65 °C
Termiline desinfitatsioon:	maks. 70 °C / 4 min

14146000 / 14466000 / 15447XXX / 31451000 / 31466000 / 31486000 / 31487000 / 31646000 / 31946000 / 32477000: Tagasivooluklapp

Toode on ette nähtud eranditult joogivee jaoks!

Sümbolite kirjeldus



Ärge kasutage äädikhapet sisaldavat silikooni!



Reguleerimine (vt lk 33)

Sooja vee piirangu seadistamine. Ühenduses boileritega ei ole sooja vee blokeeringu soovitatav.



Mõõtude (vt lk 34)



Läbivooludiagramm

(vt lk 35)

- ① Duši väljund
- ② Vanni väljund



Kasutamine (vt lk 41)



Hooldus (vt lk 36)

14146000 / 14466000 / 15447XXX / 31451000 / 31466000 / 31486000 / 31487000 / 31646000 / 31946000 / 32477000: Ohutusseadeldiste toimimist tuleb regulaarselt kontrollida, vastavalt standardile DIN EN 1717 riiklike või piirkondlike määrustega kooskõlas kontrollida (standardi DIN 1988 puhul üks kord aastas).



Puhastamine (vt kaasasolevast brošüürist)



Varuosad (vt lk 38)



Kontrollsertifikaat (vt lk 48)

Rike	Põhjus	Lahendus
Segisti käib raskelt	- Tööelement on katkine, lubjastunud	- Vahetage tööelement
Segisti tilgub	- Tööelement on katkine	- Vahetage tööelement
Liiga madal sooja vee temperatuur, külma vett pole. Läbivoolu boiler hakkab tööle, kui on valitud külm vesi.	- Kuumu vee piirang valesti seatud - Ristvool	- Seadke kuumu vee piirang - Vahetage tööelement
Ümberlülit ei tööta	- Setted - Vee surve liiga madal - Ümberlülit defektne	- Ümberlülit puhastamine / O-tihendite määrimine - Tõstke vee survet - Ümberlülit välja vahetada



Paigaldamine vt lk 31



Drošības norādes

- ⚠ Montāžas laikā, lai izvairītos no saspiedumiem un iegriezumiem, nepieciešams nēsāt cimdus.
- ⚠ Šo produktu drīkst izmantot tikai, lai mazgātos, higiēnai un ķermeņa tīrīšanai.
- ⚠ Jāizlīdzina spiediena atšķirības starp aukstā un karstā ūdens pievadiem.

Norādījumi montāžai

- Pirms montāžas nepieciešams pārbaudīt, vai produktam transportēšanas laikā nav radušies bojājumi. Pēc iebūvēšanas bojājumi, kas radušies transportēšanas laikā, vai virsmas bojājumi netiek atzīti.
- Caurulvadi un armatūra ir jāuzstāda, jāizskalo un jāpārbauda saskaņā ar spēkā esošajiem standartiem.
- Jāievēro attiecīgās valstīs spēkā esošās montāžas prasības.

Tehniskie dati

Darba spiediens:	maks. 1 MPa
Ieteicamais darba spiediens:	0,1 - 0,5 MPa
Pārbaudes spiediens:	1,6 MPa
(1 MPa = 10 bar = 147 PSI)	
Karstā ūdens temperatūra:	maks. 80 °C
Ieteicamā karstā ūdens temperatūra:	65 °C
Termiskā dezinfekcija :	maks. 70 °C / 4 min

14146000 / 14466000 / 15447XXX / 31451000 / 31466000 / 31486000 / 31487000 / 31646000 / 31946000 / 32477000: Drošības vārsts

Izstrādājums ir paredzēts tikai dzeramajam ūdenim!

Simbolu nozīme



Neizmantojiet silikonu, kas satur etiķskābi!



Ieregulēšana (skat. lpp. 33)

Karsta ūdens ierobežotāja regulēšana. Kopā ar caurteces sildītājiem nav ieteicams izmantot ūdens bloķētāju.



Izmērus (skat. lpp. 34)



Caurplūdes diagramma

(skat. lpp. 35)

- ① Dušas izeja
- ② Vannas izeja



Lietošana (skat. lpp. 41)



Apkope (skat. lpp. 36)

14146000 / 14466000 / 15447XXX / 31451000 / 31466000 / 31486000 / 31487000 / 31646000 / 31946000 / 32477000: Drošības iestatījumu funkcionalitāte ir jāpārbauda regulāri atbilstoši DIN EN 1717 un saskaņā ar valsts vai reģionālajiem noteikumiem (saskaņā ar DIN 1988 vienreiz gadā).



Tīrīšana (skatiet pievienotajā brošūrā)



Rezerves daļas (skat. lpp. 38)



Pārbaudes zīme (skat. lpp. 48)

Traucējums	Iemesls	Bojājumu novēršana
Jaucējkrāns smagi grozāms	- Bojāta kartuša, aizkalķojusies	- Nomainīt kartušu
Jaucējkrāns pil	- Bojāta kartuša	- Nomainīt kartušu
Pārāk zema ūdens temperatūra, nav aukstā ūdens, izvēloties auksto ūdeni, sāk darboties caurteces sildītājs	- Nepareizi noregulāta karstā ūdens bloķēšana	- Noregulēt karstā ūdens ierobežošanu
Pārslēdzējs nestrādā	- Ūdens sajaukšanās	- Nomainīt kartušu
	- Nogulsnes	- Tīriet pārslēdzēju / eļļojiet blīvējošos gredzenus
	- Nepietiekams ūdens spiediens	- Paaugstināt ūdens spiedienu
	- Bojāts pārslēdzējs	- Nomainīt pārslēdzēju



Montāža skat. lpp. 31



Srpski

Sigurnosne napomene

- ⚠ Prilikom montaže se radi sprečavanja prignječenja i posekotina moraju nositi rukavice.
- ⚠ Proizvod sme da se koristi samo za kupanje, tuširanje i ličnu higijenu.
- ⚠ Velika razlika u pritisku između vruće i hladne vode mora biti izbalansirana.

Instrukcije za montažu

- Pre montaže se mora proveriti da li je proizvod oštećen pri transportu. Nakon ugradnje se ne priznaju nikakve reklamacije koje se odnose na površinska i transportna oštećenja.
- Vodovi i armatura moraju biti postavljeni, isprani i testirani prema važećim normama.
- Treba se pridržavati propisa koji u određenim zemljama važe za instalacije.

Tehnički podaci

Radni pritisak:	maks. 1 MPa
Preporučeni radni pritisak:	0,1 - 0,5 MPa
Probni pritisak:	1,6 MPa
(1 MPa = 10 bar = 147 PSI)	
Temperatura vruće vode:	maks. 80 °C
Preporučena temperatura vruće vode:	65 °C
Termička dezinfekcija:	maks. 70 °C / 4 min

14146000 / 14466000 / 15447XXX / 31451000 /
31466000 / 31486000 / 31487000 / 31646000 /
31946000 / 32477000: Zaštita od povratnog toka

Proizvod je koncipiran isključivo za pijaću vodu!

Opis simbola



Nemojte koristiti silikon koji sadrži sirćetnu kiselinu!



Podešavanje (vidi stranu 33)

Podešavanje ograničivača tople vode. U kombinaciji sa protočnim bojlerima ne preporučuje se primena sistema za blokiranje dotoka tople vode.

Mere (vidi stranu 34)



Dijagram protoka

(vidi stranu 35)

- ① Ogranak tuš
- ② Ogranak kada



Rukovanje (vidi stranu 41)



Održavanje (vidi stranu 36)

14146000 / 14466000 / 15447XXX
/ 31451000 / 31466000 / 31486000
/ 31487000 / 31646000 / 31946000
/ 32477000: Ispravno funkcionisanje bezbednosnih elemenata se mora redovno proveravati prema standardu DIN EN 1717 i u skladu s važećim nacionalnim ili regionalnim propisima (DIN 1988 jednom godišnje).



Čišćenje (vidi priloženoj brošuri)



Rezervni delovi (vidi stranu 38)



Ispitni znak (vidi stranu 48)

Smetnja	Uzrok	Pomoć
Ručica se zaglavila	- Neispravna kartuša, nataloženi kamenac	- Zamenite kartušu
Slavina kaplje	- Neispravna kartuša	- Zamenite kartušu
Preniska temperatura tople vode, nema hladne vode. Protočni bojler se pali iako je puštena hladna voda.	- Ograničavač vruće vode nije dobro podešen - Ukršteni tok vode	- Podesite ograničavač vruće vode - Zamenite kartušu
Preusmerivač ne radi	- Naslage - Prenizak pritisak vode - Preusmerivač je neispravan	- Čišćenje preusmerivača i podmazivanje O-prstenova - Povećajte pritisak vode - Zamenite preusmerivač



Montaža vidi stranu 31



Sikkerhetshenvisninger

- ⚠ Bruk hansker under montasjen for å unngå klem- og kuttskader.
- ⚠ Dusjsystemet skal kun brukes for bade-, hygiene- og kroppshygiene.
- ⚠ Store trykkdifferanser mellom kaldt- og varmtvannstilkoblinger skal utlignes.

Montagehenvisninger

- Før montasjen skal produktet sjekkes for transportskader. Etter monteringen aksepteres ikke noen transport- eller overflateskader.
- Ledningene og armaturen skal monteres, spyles og sjekkes iht. de gyldige normer.
- Gjeldende retningslinjer for rørleggerarbeid i de enkelte land skal følges.

Tekniske data

Driftstrykk	maks. 1 MPa
Anbefalt driftstrykk:	0,1 - 0,5 MPa
Prøvetrykk	1,6 MPa
(1 MPa = 10 bar = 147 PSI)	
Varmtvannstemperatur	maks. 80 °C
Anbefalt temperatur for varmt vann	65 °C
Termisk desinfisering:	maks. 70 °C / 4 min

14146000 / 14466000 / 15447XXX / 31451000 / 31466000 / 31486000 / 31487000 / 31646000 / 31946000 / 32477000: Egensikker mot tilbakeflyt

Produktet er utelukkende designet for drikkevann!

Symbolbeskrivelse



Ikke bruk silikon som inneholder eddiksyre!



Justering (se side 33)

Innstilling av varmtvannsbegrensning. I forbindelse med gjennomstrømningsvarmere er det ikke anbefalt å bruke en varmtvannspærre.



Mål (se side 34)



Gjennomstrømningsdiagram

(se side 35)

- ① Utgang dusj
- ② Utgang kar



Betjening (se side 41)



Vedlikehold (se side 36)

14146000 / 14466000 / 15447XXX / 31451000 / 31466000 / 31486000 / 31487000 / 31646000 / 31946000 / 32477000: Funksjonen til sikkerhetsinnretninger skal kontrolleres iht. DIN EN 1717 og i samsvar med de nasjonale og lokale forskrifter, sjekkes regelmessig (DIN 1988 en gang i året).



Rengjøring (se vedlagt brosjyre)



Serviceedeler (se side 38)



Prøvemerke (se side 48)

Feil	Årsak	Feilrettelse
Armatyr ikke lett bevegelig	- Kartusj defekt, forkalkning	- Kartusj byttes
Armatyr drypper	- Kartusj defekt	- Kartusj byttes
For lav varmtvannstemperatur, ikke noe kaldtvann. gjennomstrømningsvannvarmer slår seg på når det velges kaldt vann.	- Varmtvannsbegrensning er feil innstilt	- Varmtvannsbegrensning innstilles
	- Krysstrømning	- Kartusj byttes
Omstiller fungerer ikke	- Avleiringer	- Rengjøre omstiller / smøre O-ringer
	- For lavt vanntrykk	- Øke vanntrykk
	- Omstiller defekt	- Omstiller byttes



Montasje se side 31



БЪЛГАРСКИ

Указания за безопасност

- ⚠ При монтажа трябва да се носят ръкавици, за да се избегнат наранявания поради притискане или порязване.
- ⚠ Позволено е използването на продукта само за къпане, хигиена и цели на почистване на тялото.
- ⚠ Големите разлики в налягането между изводите за студената и топлата вода трябва да се изравняват.

Указания за монтаж

- Преди монтажа продуктът трябва да се провери за транспортни щети. След монтажа не се признават транспортни или повърхностни щети.
- Тръбопроводите и арматурата трябва да се монтират, промият и проверят в съответствие с валидните норми.
- Трябва да бъдат спазвани валидните в съответните страни предписания за инсталиране.

Технически данни

Работно налягане: макс. 1 МПа
 Препоръчително работно налягане: 0,1 - 0,5 МПа
 Контролно налягане: 1,6 МПа
 (1 МПа = 10 bar = 147 PSI)
 Температура на горещата вода: макс. 80 °C
 Препоръчителна температура на горещата вода: 65 °C
 Термична дезинфекция: макс. 70 °C / 4 мин
 14146000 / 14466000 / 15447XXX / 31451000 / 31466000 / 31486000 / 31487000 / 31646000 / 31946000 / 32477000: Самозащитен против обратно изтичане

Продуктът е разработен само за питейна вода!

Описание на символите



Не използвайте силикон, съдържащ оцетна киселина!



Юстиране (вижте стр. 33)

Настройка на ограничителя за топлата вода. Във връзка с проточни нагреватели не се препоръчва блокировка за топлата вода



Размери (вижте стр. 34)



Диаграма на потока
(вижте стр. 35)

- ① Изход разпръсквател
- ② Извод вана



Обслужване (вижте стр. 41)



Поддръжка (вижте стр. 36)

14146000 / 14466000 / 15447XXX / 31451000 / 31466000 / 31486000 / 31487000 / 31646000 / 31946000 / 32477000: Съгласно DIN EN 1717 функционирането на предпазните приспособления трябва да се проверява на редовно в съответствие с националните или регионални изисквания (DIN 1988 веднъж годишно).



Почистване (от приложената брошура)



Сервизни части (вижте стр. 38)



Контролен знак (вижте стр. 48)

Неизправност	Причина	Помощ
Трудно подвижна арматура	- Дефектна гилза, покрита с варовик	- Сменете гилзата
Арматурата капе	- Дефектна гилза	- Сменете гилзата
Твърде ниска температура на топлата вода, няма студена вода.	- Ограничението за топлата вода е грушно настроено	- Настройте ограничението за топлата вода
Проточният нагревател се задейства, когато се избере студена вода	- Кръстосване на потока	- Сменете гилзата
Превключвателят не функционира	- Отлагания	- Почистете превключвателя / Смажете O-образните пръстени
	- Твърде малко налягане на водата	- Повишаване на налягането на водата
	- Дефектен превключвател	- Сменете превключвателя



Монтаж вижте стр. 31



Udhëzime sigurie

- ⚠ Për të evituar lëndimet e pickimeve ose të prerjeve gjatë procesit të montimit duhet që të vishni doreza.
- ⚠ Produkti duhet të përdoret vetëm qëllimet e banjave, të higjienës dhe të larjes së trupit.
- ⚠ Ndryshimet e mëdha të presionit mes lidhjeve të ujit të ftohtë dhe atij të ngrohtë duhen ekuilibruar.

Udhëzime për montimin

- Përpara montimit duhet që produkti të kontrollohet për dëmtime nga transporti. Pas instalimit nuk do të njihet asnjë dëmtim nga transporti ose dëmtim i sipërfaqes.
- Tubacionet dhe rubinetet duhet që të montohen, të shpëlahen dhe të kontrollohen sipas standardeve në fuqi
- Duhet të respektohen linjat udhëzuese të instalimit, të vlefshme për vendet respektive.

Të dhëna teknike

Presioni gjatë punës	maks. 1 MPa
Presioni i rekomanduar:	0,1 - 0,5 MPa
Presioni për provë:	1,6 MPa
(1 MPa = 10 bar = 147 PSI)	
Temperatura e ujit të ngrohtë	maks. 80 °C
Temperatura e rekomanduar e ujit të ngrohtë:	65 °C
Dezinfektim Termik:	maks. 70 °C / 4 min

14146000 / 14466000 / 15447XXX / 31451000 / 31466000 / 31486000 / 31487000 / 31646000 / 31946000 / 32477000: Siguresa kundër rrjedhjes në drejtim të kundërt

Produkti është projektuar ekskluzivisht për ujë të pijshëm!

Përshkrimi i simbolit



Mos përdorni silikon që në përbërje ka acid acetik.



Justimi (shih faqen 33)

Rregullimi i kufizimit me ujë të nxehtë. Një kombinim me një bojler ujit nuk është i rekomanduar.



Përmasat (shih faqen 34)



Diagrami i qarkullimit (shih faqen 35)

- ① Dalja e spërkatëses
- ② Dalja e vaskës



Përdorimi (shih faqen 41)



Mirëmbajtja (shih faqen 36)

14146000 / 14466000 / 15447XXX / 31451000 / 31466000 / 31486000 / 31487000 / 31646000 / 31946000 / 32477000: Pajisjet në shërbim të sigurisë duhen kontrolluar rregullisht në bazë të normave DIN EN 1717 konform normave nacionale dhe regionale (DIN 1988 një herë në vit).



Pastrimi (shikoni broshurën bashkëngjitur)



Pjesët e servisit (shih faqen 38)



Shenja e kontrollit (shih faqen 48)

Dëmtim	Shkaku	Ndihme
Armatura punon rende	- Kartusha me defekt, me kalk	- Kembeni kartushen
Armatura pikon	- Kartusha me defekt	- Kembeni kartushen
Temperaturë e ulët e ujit të ngrohtë, nuk ka ujë të ftohtë. Ngrohësi elektrik i ujit ndizet kur zgjidhet uji i ftohtë.	- Kufiri i ujit të ngrohtë është regjistruar gabim	- Regjistroni kufirin e ujit të ngrohtë
Kalibruesi nuk funksionon	- Rrjedhje e kryqëzuar.	- Kembeni kartushen
	- Dekompozimet	- Pastroni ndërruesin e pozicionit / Vajosni unazat O
	- Presion shumë i ulët i ujit	- Rrisni presionin e ujit
	- Kalibruesi me defekt	- kembeni kalibruesin



Montimi shih faqen 31



وصف الرمز

هام! لا تستخدم السليكون الذي يحتوي على أحماض!



الضبط (راجع صفحة 33)

ضبط تحديد المياه الدافئة. لا ينصح باستخدام محدد المياه الدافئة مع سخان المياه الوقتي.



أبعاد (راجع صفحة 34)



رسم للصراف (راجع صفحة 35)



- ① صرف الرشاش
- ② صرف البانيو

التشغيل (راجع صفحة 41)



الصيانة (راجع صفحة 36)



15447XXX / 14466000 / 14146000
31451000 / 31466000 / 31486000 /
31487000 / 31646000 / 31946000 /
32477000 : يجب إختبار وظائف تجهيزات
الأمان طبقاً للوائح DIN EN 1717 وبشكل
دوري وذلك بالتوافق مع القواعد المحلية
والجهوية السائدة DIN 1988 وبشكل
سنوي.

التنظيف (راجع والكتيب المرفق)



قطع الغيار (راجع صفحة 38)



شهادة اختبار (راجع صفحة 48)



تنبيهات الأمان ⚠️

⚠️ يجب إرتداء قفازات ليد أثناء التركيب لتجنب حدوث أخطار الإحترق أو الجروح.

⚠️ لا يجب استخدام نظام الدش إلا في أغراض الاستحمام والأغراض الصحية وأغراض تنظيف الجسم.

⚠️ يجب أن يكون تيار الماء الساخن والماء البارد متعادلين في الضغط.

تعليمات التركيب

• قبل القيام بعملية التركيب. يجب فحص المنتج للتأكد من خلوه من أية تلفيات ناجمة عن النقل. بعد القيام بعملية التركيب. لن يتم الاعتراف بوجود أية تلفيات سطحية أو تلفيات ناجمة عن عملية النقل.

• يجب تركيب وغسيل واختبار التوصيلات وخلطات المياه طبقاً للمعايير السارية.

• يجب مراعاة القواعد الخاصة بالتركيب وأعمال السباكة وفقاً للوائح الخاصة بكل بلد.

المواصفات الفنية

ضغط التشغيل: الحد الأقصى 1 ميجاباسكال
ضغط التشغيل الموصى به: 0,5 - 0,1 ميجاباسكال
ضغط الاختبار: 1,6 ميجاباسكال
(1 ميجاباسكال = 10 بار = 147 PSI)
درجة حرارة الماء الساخن: الحد الأقصى 80°C
درجة الحرارة الموصى بها للماء الساخن: 65°C
تقييم حراري: الحد الأقصى 70°C / 4 الدقيقة

15447XXX / 31451000 / 14466000 / 14146000
/ 31466000 / 31486000 / 31487000 /
32477000 / 31946000 / 31646000: خاصة عدم
التدفق العكسي

المنتج مخصص فقط لماء الشرب!

العطل	السبب	العلاج والإصلاح
الخلاط ثقيل الحركة	- الخرطوشة تالفة. تراكم عليها الجير	- قم بتغيير الخرطوشة
تساقط قطرات مياه من الخلاط	- الخرطوشة تالفة	- قم بتغيير الخرطوشة
درجة حرارة الماء الساخن منخفضة للغاية. ولا يوجد ماء بارد. سخان المياه الضوري يعمل عند استخدام الماء البارد.	- محدد الماء الساخن مضبوط بشكل خاطيء - اندفاع متعاكس للمياه	- قم بضبط محدد الماء الساخن
المحول لا يعمل	- الرواسب	- قم بتغيير الخرطوشة
	- ضغط الماء منخفض للغاية	- تنظيف الخلاط وتشحيم الحلقة الدائرية.
	- المحول تالف	- ارفع ضغط الماء
		- قم بتغيير المحول

التركيب راجع صفحة 31



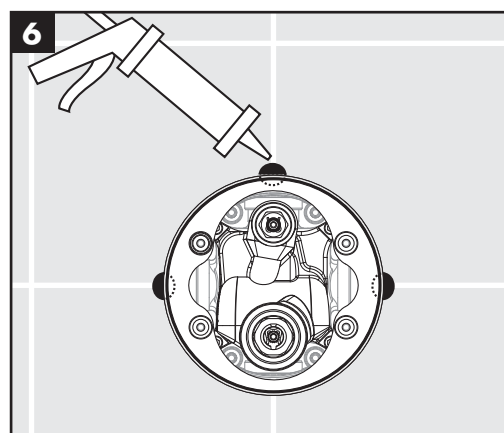
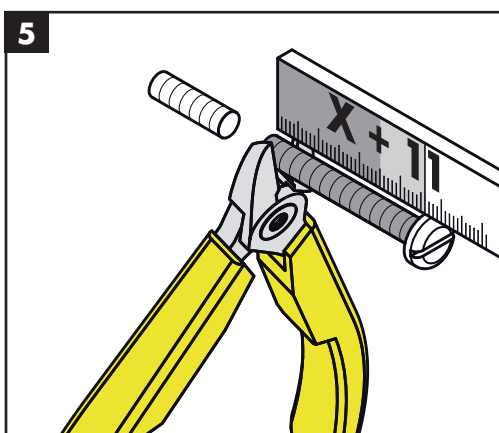
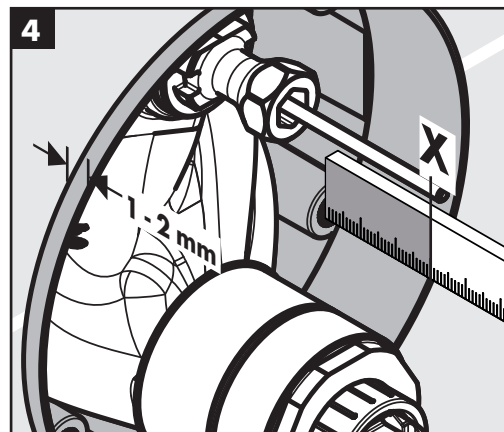
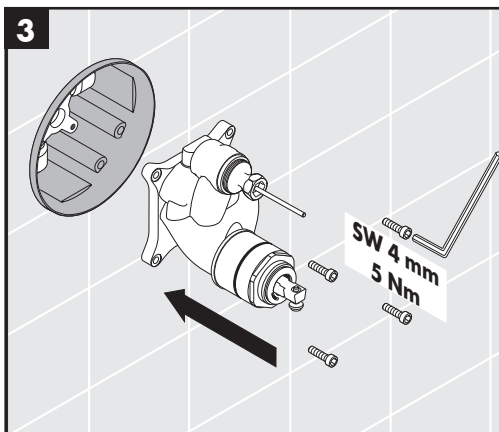
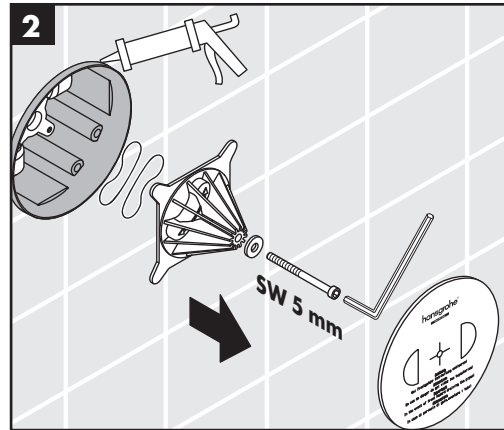
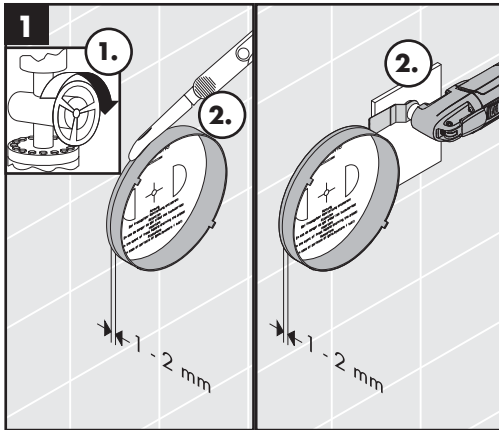

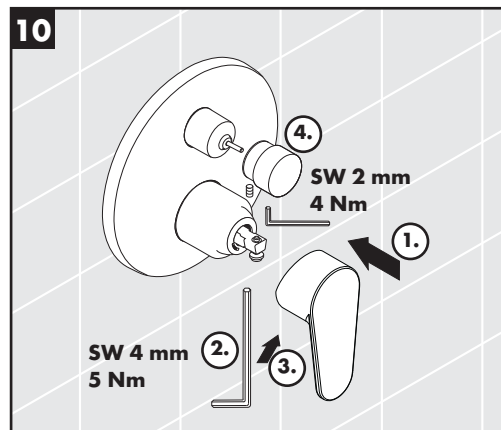
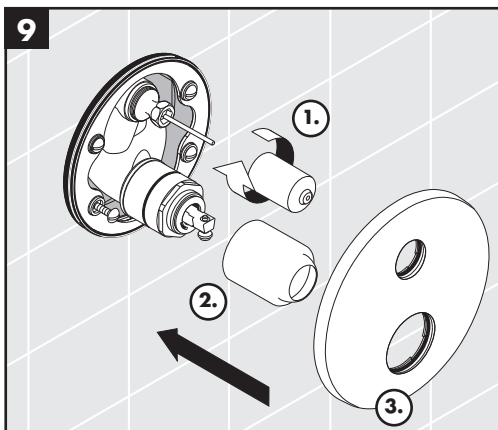
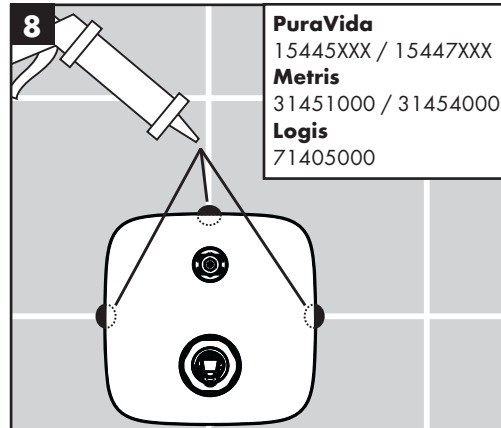
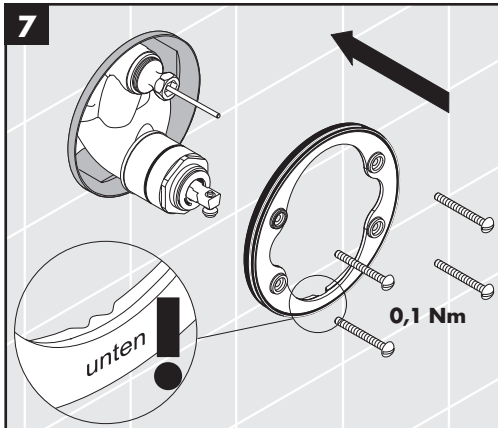

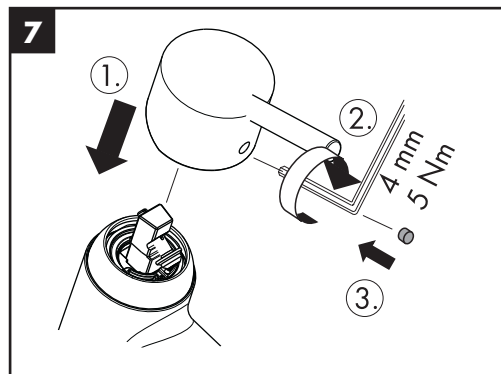
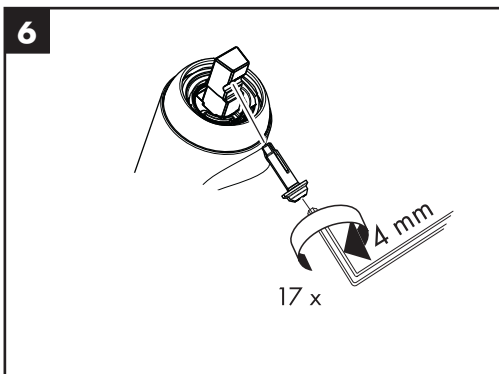
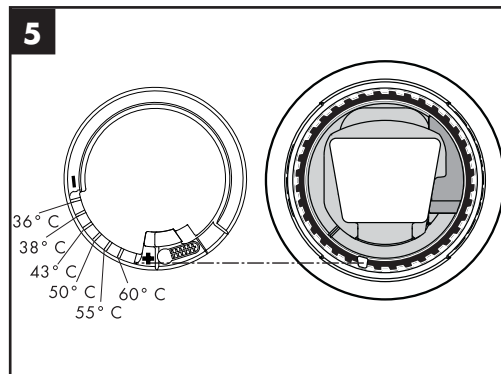
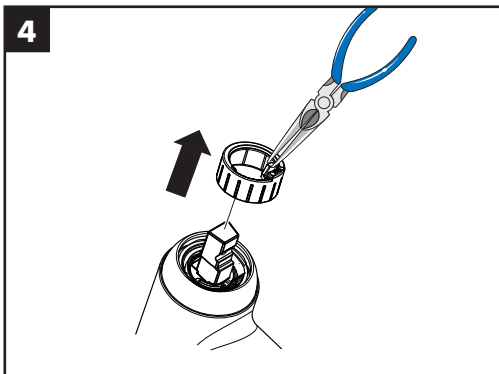
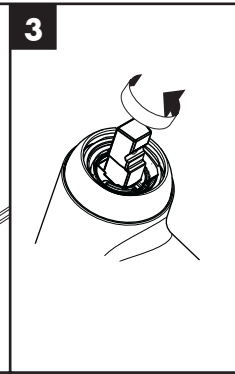
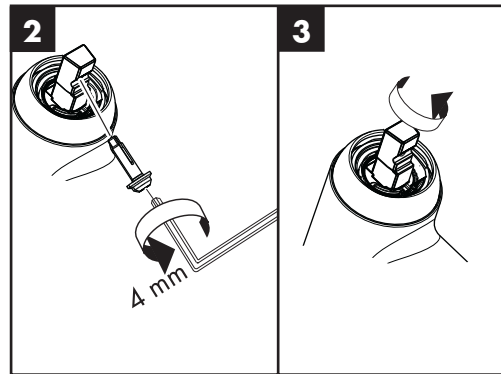
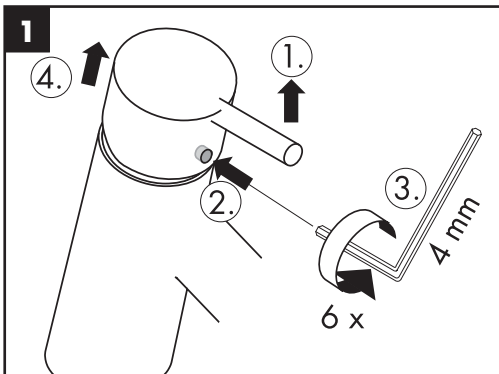



Talis Classic
14145000 /
14146000

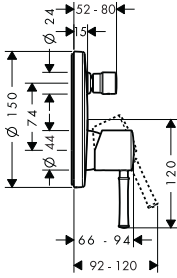

Metropol S
14465000 /
14466000

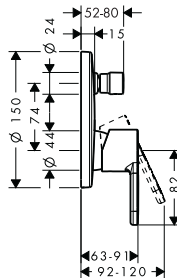

PuraVida
15445XXX /
15447XXX

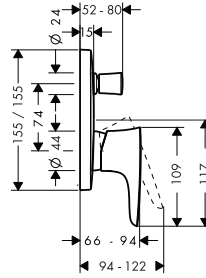

Metris
31451000 /
31454000

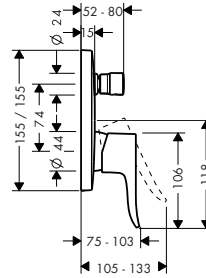

Metris S
31465000 /
31466000

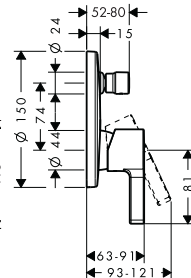

Metris Classic
31485000 /
31486000

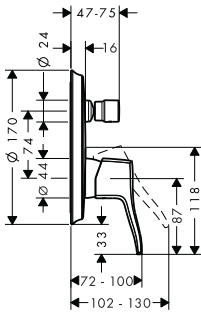

Metris
31487000 /
31493000

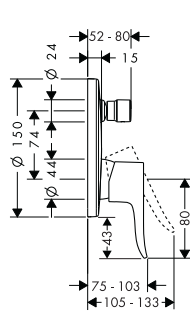

Talis E²
31645000 /
31646000

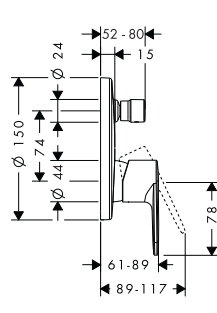

Focus S
31743000

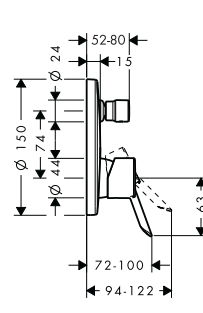

Focus E
31744000

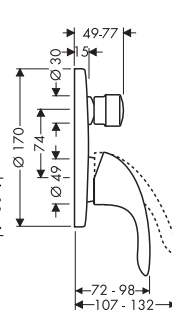

Talis
32475000 /
32477000

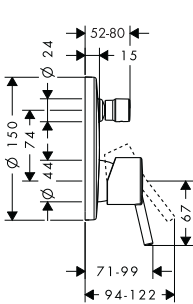

Focus
31945000 /
31946000

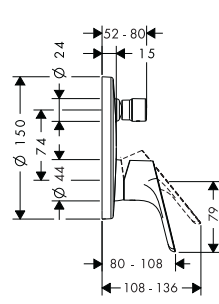

Logis
71405000

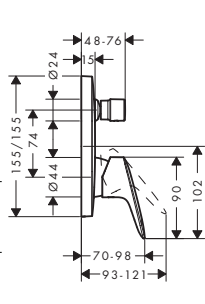



Metris	31454000
Metris	31493000
Talis Classic	14145000
Metris Classic	31485000
Talis	32475000
Metris S	31465000
Metropol S	14465000
PuraVida	15445XXX
Talis E²	31645000
Focus S	31743000
Focus	31945000
Focus E	31744000
Logis	71405000

Metris	31451000
Metris	31487000
Talis Classic	14146000
Metris Classic	31486000
Talis	32477000
Metris S	31466000
Metropol S	14466000
PuraVida	15447XXX
Talis E²	31646000
Focus	31946000

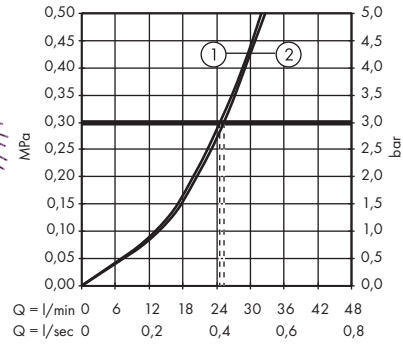
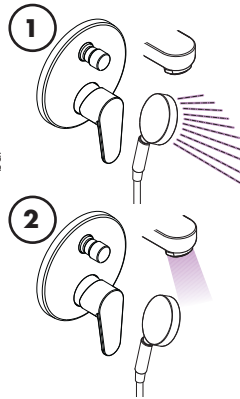
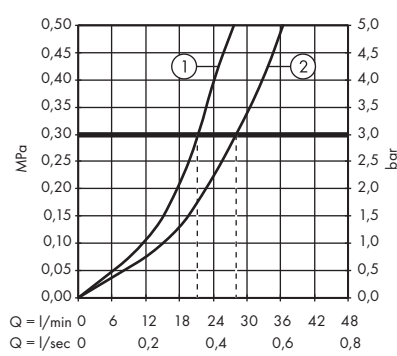



14146000 / 14466000 / 15447XXX / 31451000 / 31466000 / 31486000 /
31487000 / 31646000 / 31946000 / 32477000

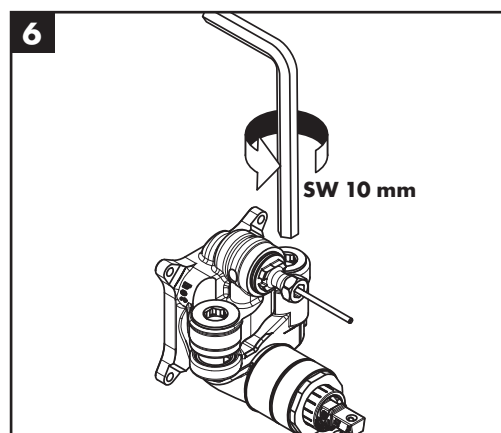
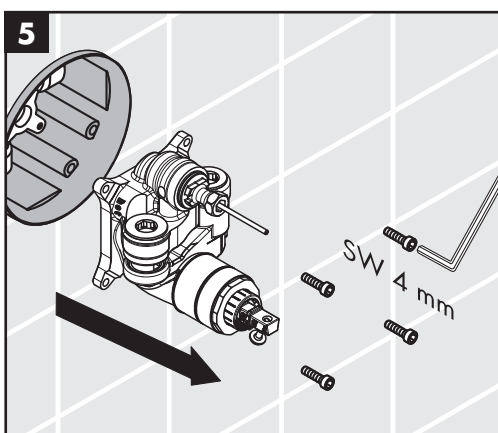
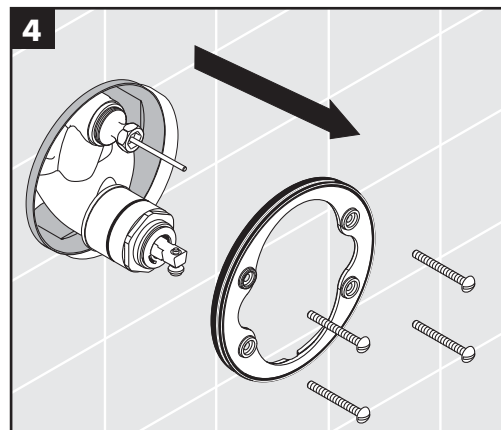
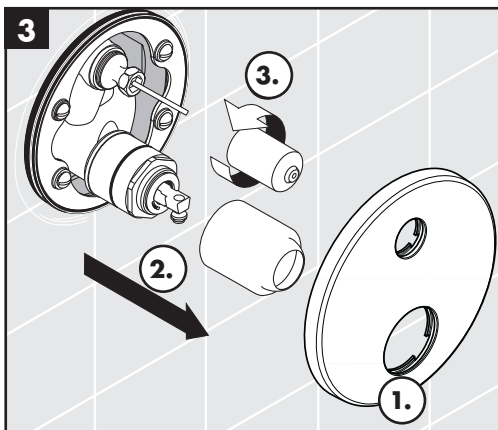
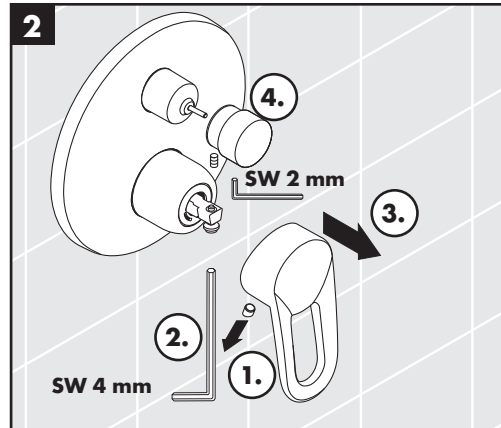
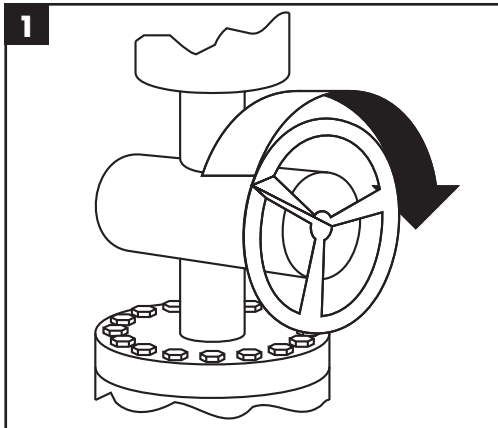

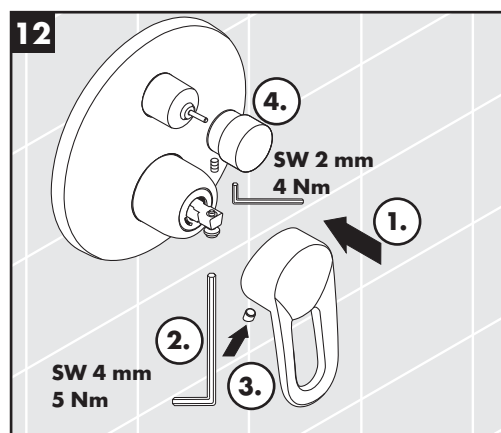
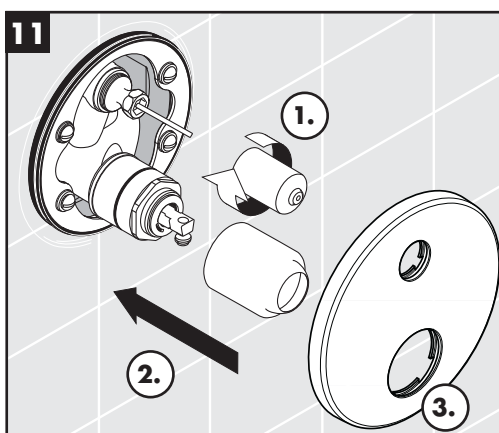
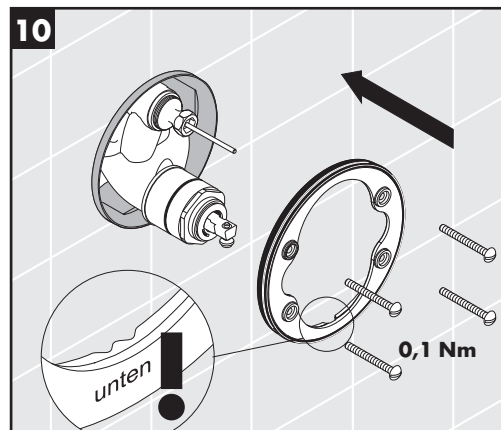
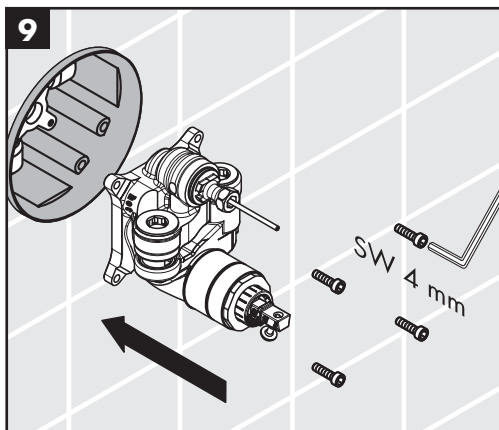
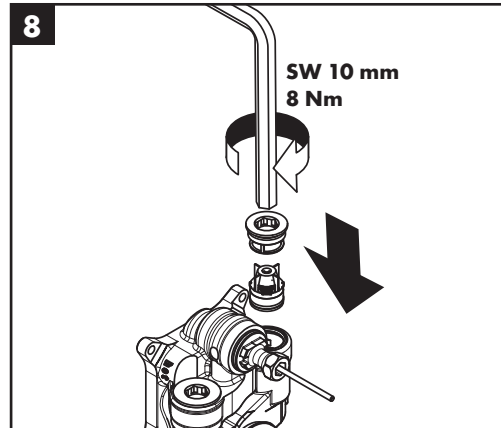
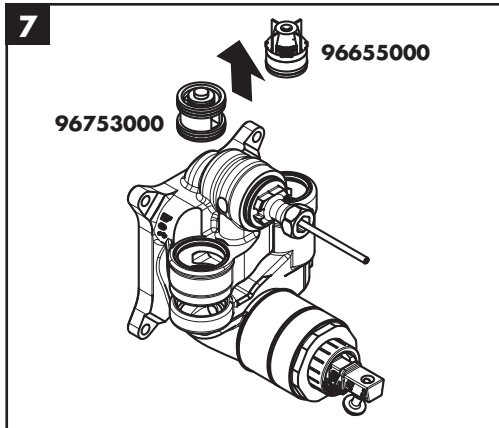

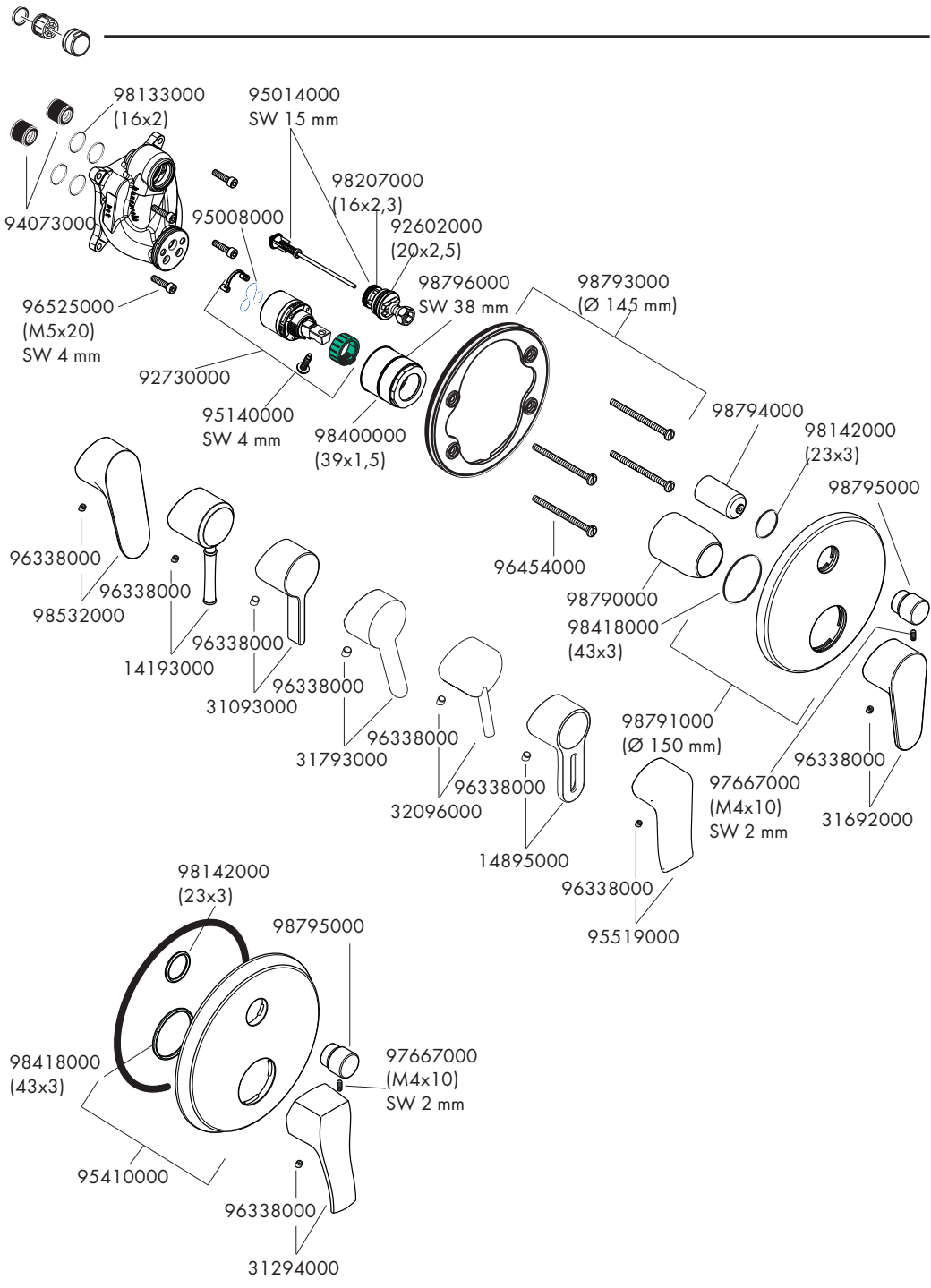

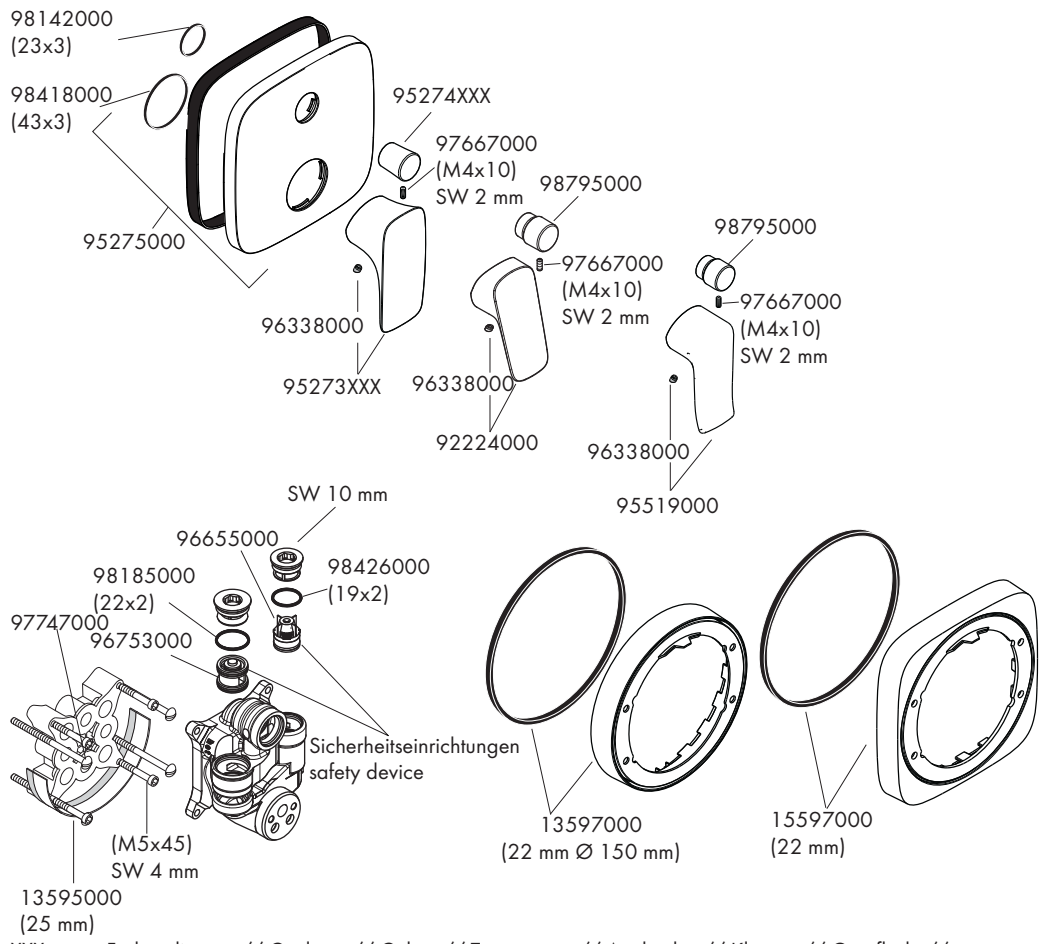

- XXX = Farbcodierung // Couleurs // Colors // Trattamento // Acabados // Kleuren // Overflade // Acabamentos // kody wykończenia powierzchni // kód povrchové úpravy // kód povrchovej úpravy // 颜色代码 // Код цвета поверхности // Színkódok // Värikoodi // Färgkodning // Spalva // Boje // Renkler // cod de culori // Χρώματα // Barve // Värvikood // Krāsas // Oznake boja // Oznake boja // Oznake boja // الألوان
- 000 = chrom // chromé // chrome plated // cromato // cromado // verchromd // Krom // cromado // chrom // chrom // chróm // 镀铬 // хром // króm // kromi // krom // chrom // krom // krom // crom // Επιχρωµωμένο // krom // kroom // hroma // hrom // hrom // hrom // hrom // كروم
- 400 = weiß/chrom // blanc/chromé // white/chrome plated // bianco/cromato // blanco/cromado // wit/verchromd // Hvid/Krom // branco/cromado // biały/chrom // bílá/chrom // biela/chróm // 白色/镀铬 // белый/хром // fehéř/króm // valkoinen/kromi // vit/krom // balta/chrom // bijela/krom // beyaz/Krom // alb/crom // λευκό/Επιχρωµωμένο // bela/krom // valge/kroom // balta/hroma // bela/hrom // bela/hrom // bela/hrom // bela/hrom // أبيض/كروم

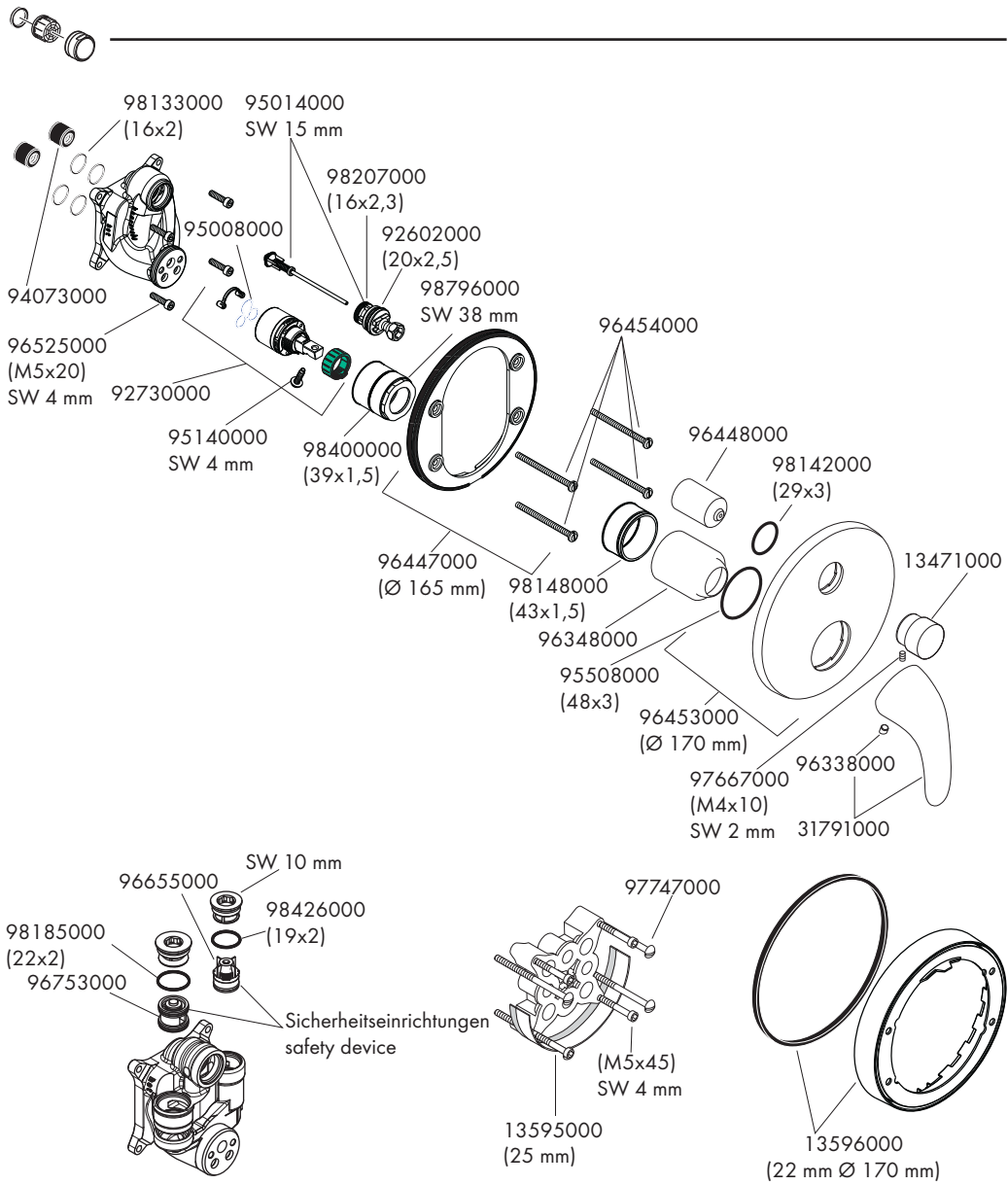

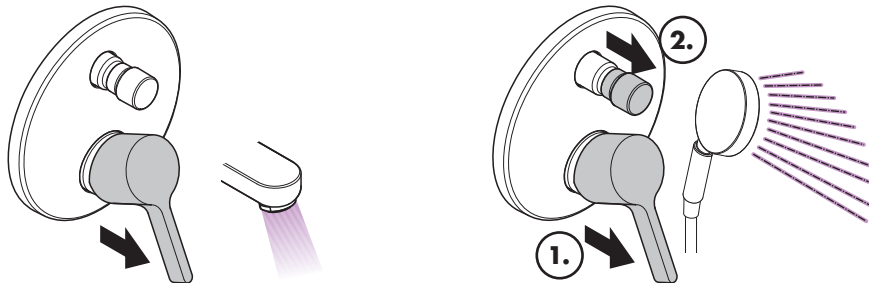

öffnen / ouvert / open / aperto / abierto / open / åbne / abrir / otworzyć / otevřít / otvorit / 开 / открыть / nyitás /
avaaminen / öppna / atidaryti / Otvaranje / açmak / deschide / ανοικτό / odpreti / avage / atvērt / otvoriti /
اُفنه / отварање / hare / فتح

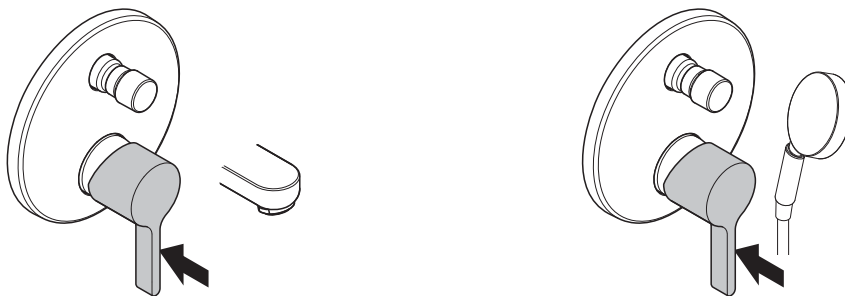

schließen / fermé / close / chiudere / cerrar / sluiten / lukke / fechar / zamknąć / zavřít / uzavrieť / 关 / закрыть /
bezárás / sulkeminen / stänga / uždaryti / Zatvaranje / kapatmak / închide / κλειστό / zapreti / sulgege / aizvērt /
zatvori / lukke / затварање / mbylle / إغلاق

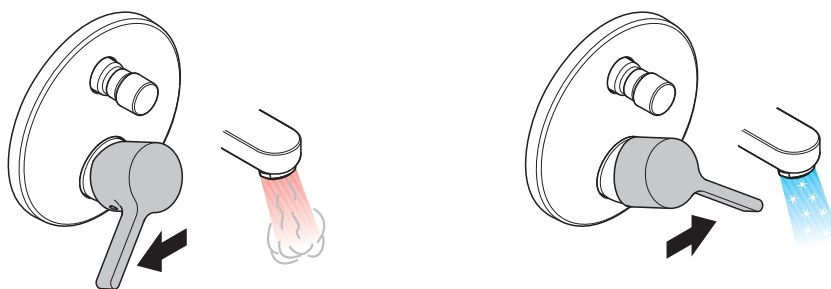

warm / chaud / hot / caldo / caliente / warm / varmt /
quente / ciepła / teplá / teplá / 热 / горячая / meleg /
lämmin / varmt / karštas / Vruća voda / sıcak / cald /
ζεστό / toplo / kuum / karsts / topla / varm / тепло /
i ngrohtë / ساخن

kalt / froid / cold / freddo / frío / koud / koldt / fria /
zimna / studená / studená / 冷 / холодная / hideg /
kylmä / kallt / šaltas / Hladno / soğuk / rece / κρύο /
mrzlo / külm / auksts / hladno / kaldt / студено / i fjohtë /
بارد









	PA-IX	DVGW	SVGW	NF	WRAS	KIWA	ACS	ETA
14145000	PA-IX 9709/ICC		X		X			Va 1.42/18751
14146000	PA-IX 18097/IDC		X	X				
14465000	PA-IX 9709/ICC		X		X	X	X	Va 1.42/18751
14466000	PA-IX 18097/IDC	BN0685	X	X				
15445XXX	PA-IX 9709/ICC		X		X			Va 1.42/18751
15447XXX	PA-IX 18097/IDC		X	X				
31451000								
31454000								
31465000	PA-IX 9709/ICC		X		X	X	X	Va 1.42/18751
31466000	PA-IX 18097/IDC	BN0685	X	X				
31485000	PA-IX 9709/ICC		X		X			Va 1.42/18751
31486000	PA-IX 18097/IDC		X	X				
31487000	PA-IX 18097/IDC		X					
31493000	PA-IX 9709/ICC		X		X			Va 1.42/18751
31645000	PA-IX 9709/ICC		X		X	X	X	Va 1.42/18751
31646000	PA-IX 18097/IDC	BN0685	X	X				
31743000	PA-IX 9709/ICC		X		X	X	X	Va 1.42/18751
31744000	PA-IX 9709/ICC		X		X	X	X	Va 1.42/18751
31945000	PA-IX 9709/ICC		X		X			Va 1.42/18751
31946000	PA-IX 18097/IDC		X	X				
32475000	PA-IX 9709/ICC		X		X	X	X	Va 1.42/18751
32477000	PA-IX 18097/IDC	BN0685	X	X				
71405000								



Talis Classic 14145000
Metropol S 14465000
Pura Vida 15445XXX
Metris 31454000
Metris S 31465000
Metris Classic 31485000
Metris 31493000
Talis E² 31645000
Focus S 31743000
Focus E² 31945000
Talis S / Talis S² 32475000
Focus E 31744000
Logis 71405000



Talis Classic 14146000
Metropol S 14466000
Pura Vida 15447XXX
Metris 31451000
Metris S 31466000
Talis S / Talis S² 32477000
Metris Classic 31486000
Metris 31487000
Talis E² 31646000
Focus 31946000

hansgrohe