

# Multibox 4



## **Floor Heating Controller**

Flush individual room control for floor heating systems with supply shut-off

*Engineering  
GREAT Solutions*



# Multibox 4

## K, RTL und K-RTL

Multibox 4 K, RTL and K-RTL is used for decentralized control of underfloor heating. Due to the additional supply shut-off heating surfaces can be locked individually.



### Key features

- > **Additional supply pipe shut-off with vent valve**
- > **For out-of-true installation offsetting up to 6° on each side**
- > **Cover with concealed screw connection**
- > **Adjustable fitting for all wall structures, 30 mm depth compensation**

### Technical description

#### Applications:

Floor heating systems, wall heating systems, combined floor/radiator heating systems

#### Functions:

*Multibox 4 K:*

Individual room temperature control, Presetting (V-exact II), Shut-off, Venting

*Multibox 4 RTL:*

Maximum limitation of the return temperature, Presetting, Shut-off, Venting

*Multibox 4 K-RTL:*

Individual room temperature control, Maximum limitation of the return temperature, Presetting (V-exact II), Shut-off, Venting

All Multibox 4 models are equipped with an additional supply shut-off incl. vent valve. Heating surfaces can be shut-off individually.

#### Dimensions:

Valve body DN 15.  
The flush box has an overall depth of 60 mm.  
Flexible mounting thanks to variable spacing between flush box and cover of up to 30 mm.  
The cover can compensate for slanted mounting of the flush box of up to 6° on each side.  
See also Dimensions.

#### Pressure class:

PN 10

#### Setting range:

Thermostatic head K: 6 °C to 28 °C  
Return temperature limiter RTL: 0 °C to 50 °C

#### Temperature:

Max. working temperature: 90°C  
Min. working temperature: 2°C  
For all Multibox models, ensure that the system supply temperature is suitable for setting up the floor heating system.  
See also Information!

#### Material:

Valve body: Corrosion resistant Gunmetal  
O-rings: EPDM rubber  
Valve disc: EPDM rubber  
Return spring: Stainless steel  
Valve insert: Brass, PPS (polyphenylsulphide)  
Spindle: Niro-steel spindle with double O-ring sealing. The outer O-ring can be replaced under pressure.  
Plastic parts of ABS and PA.  
Sensor element: Thermostatic head K with liquid filled sensor.  
Return temperature limiter (RTL) filled with an expansible medium.

#### Surface treatment:

All models optionally with cover and visible graduation cap in white RAL 9016 or chrome-plated.

#### Marking:

TAH, flow direction arrows, II-Designation.

#### Pipe connection:

Pipe-side G 3/4 adaptor with cone suitable for compression fittings for plastic, copper, precision steel and multi-layer pipe.

## Construction

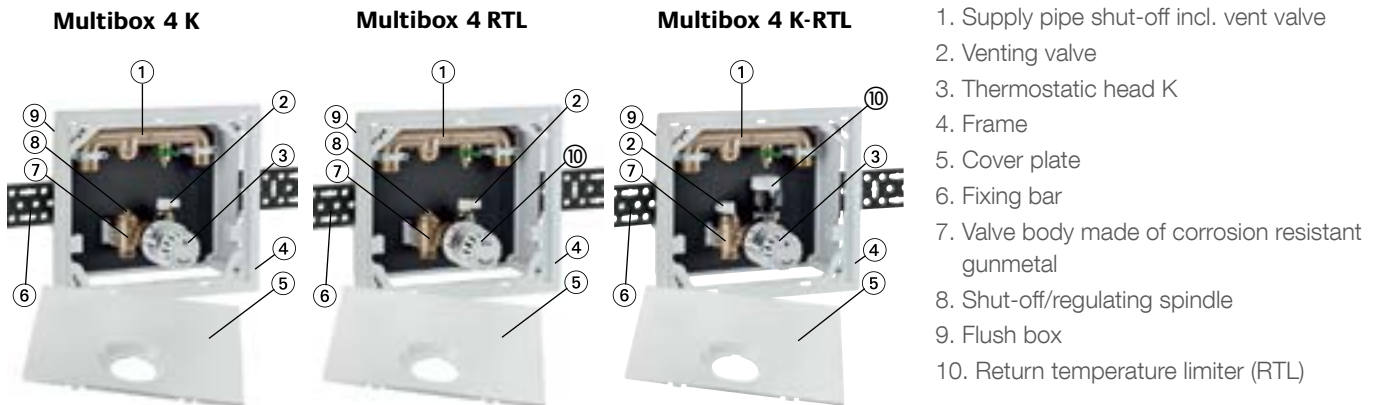

## Applications

### Multibox 4 K

Multibox 4 K is used for the individual room temperature control of, for instance, floor heating systems in association with low temperature heating systems. Multibox 4 K is also used in wall heating systems.

Use the V-exact II insert for hydraulic balancing. For e. g. maintenance work, heating surfaces can be shut-off individually.

### Multibox 4 RTL

Multibox 4 RTL is used for maximum limitation of the return temperature with, for instance, combined floor/radiator heating systems for temperature control of floor areas. Only the return temperature is controlled.

Use the shut-off/regulating spindle for hydraulic balancing. For e. g. maintenance work, heating surfaces can be shut-off individually.

### Multibox 4 K-RTL

Multibox 4 K-RTL is used for the individual room temperature control and maximum limitation of the return temperature with, for instance, combined floor/ radiator heating systems. Multibox 4 K-RTL is also used in wall heating systems.

Use the V-exact II insert for hydraulic balancing. For e. g. maintenance work, heating surfaces can be shut-off individually.

### Sample application

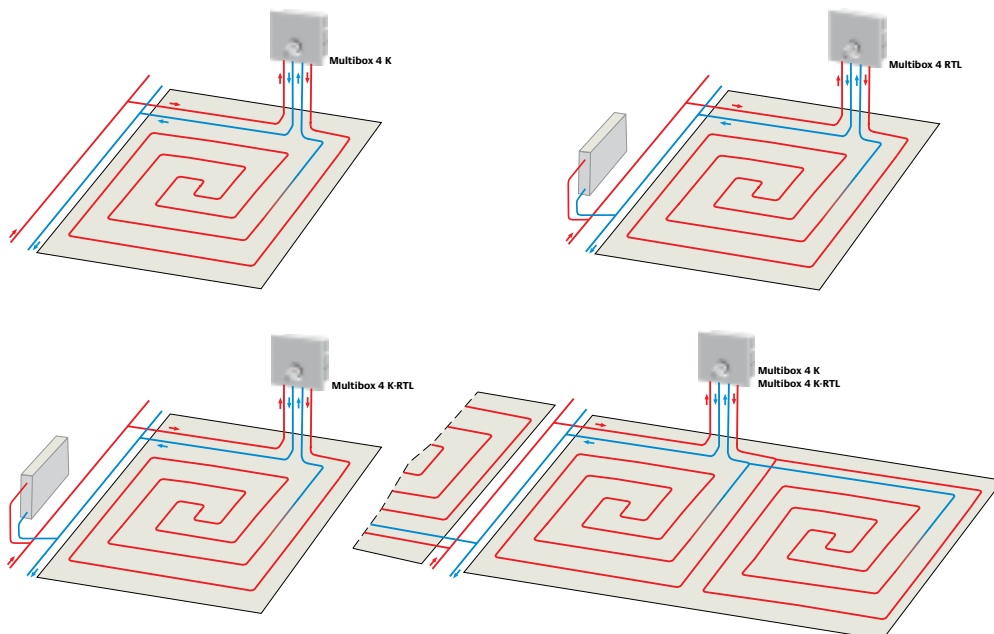

## Temperature setting

### Thermostatic head K

Cue number	*	1	)	2	3	4	5
Room temperature [°C]	6	12	14	16	20	24	28

### Return temperature limiter (RTL)

Multibox RTL							
Cue number	0	1	2	3	4	5	
Return temperature [°C]	0	10	20	30	40	50	

Multibox K-RTL							
Cue number	-	10	20	30	40	50	
Return temperature [°C]		10	20	30	40	50	

(Opening temperature)

## Function

### Multibox 4 K

From the control aspect, the thermostatic valve integrated in Multibox 4 K is a constant proportional controller (P-controller) without any auxiliary power. It does not need any electrical connection or other outside power source.

The change of the room air temperature (controlled variable) is proportional to the change of the valve lift (correcting variable). A

rise in the room air temperature e.g. from the sun's rays, results in an expansion of the liquid in the temperature sensor and it acts on the bellows.

By means of the valve spindle, this cuts back on the supply of water in the floor heating circuit. The procedure is reversed given a falling room air temperature.

### Multibox 4 RTL

From the control aspect, the return temperature limiter integrated in Multibox 4 RTL is a constant proportional controller (P-controller) without any auxiliary power. It does not need any electrical connection or other outside power source.

The temperature change of the fluid flowing through (controlled variable) is proportional to the change of the valve lift (correcting variable) and is transferred to the sensor by means of thermal conduction. Any rise in the return temperature due to, for

instance, to lowered heating output of the floor heating system as a result of outside thermal effects causes the substance in the temperature sensor to expand and act on the diaphragm plunger. By means of the valve spindle, this cuts back on the supply of water in the floor heating circuit. The procedure is reversed given a falling fluid temperature.

The valve opens when the set limiting figure is exceeded.

### Multibox 4 K-RTL

From the control aspect, the thermostatic valve integrated in Multibox 4 K-RTL is a constant proportional controller (P-controller) without any auxiliary power. It does not need any electrical connection or other outside power source.

The change of the room air temperature (controlled variable) is proportional to the change of the valve lift (correcting variable). A rise in the room air temperature e.g. from the sun's rays,

results in an expansion of the liquid in the temperature sensor of the thermostatic head and it acts on the bellows. By means of the valve spindle, this cuts back on the supply of water in the floor heating circuit. The procedure is reversed given a falling room air temperature.

Multibox 4 K-RTL is additionally provided with a return temperature limiter (RTL) which stops the set return temperature from being exceeded. The valve opens when the set limiting figure is exceeded.

## Articles

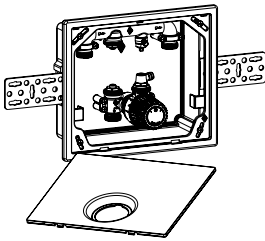

### Multibox 4 K

with thermostatic valve

Colour	EAN	Article No
Cover and thermostatic head K white RAL 9016	4024052766512	9312-00.800
Cover and thermostatic head K chrome-plated	4024052766611	9312-00.801

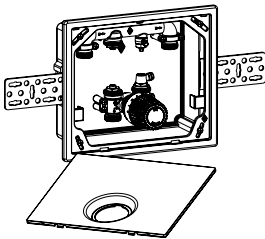

### Multibox 4 RTL

with return temperature limiter (RTL)

Colour	EAN	Article No
Cover and RTL thermostatic head white RAL 9016	4024052766710	9314-00.800
Cover and RTL thermostatic head chrome-plated	4024052766819	9314-00.801

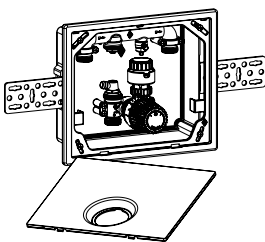

### Multibox 4 K-RTL

with thermostatic valve and  
return temperature limiter (RTL)

Colour	EAN	Article No
Cover and thermostatic head K white RAL 9016	4024052766314	9311-00.800
Cover and thermostatic head K chrome-plated	4024052766413	9311-00.801

# Multibox 4 F

Multibox 4 F is used for decentralized control of underfloor heating. Due to the additional supply shut-off heating surfaces can be locked individually.



## Key features

- > **Additional supply pipe shut-off with vent valve**
- > **Elegant and easy-to-clean graduation cap**
- > **No change in appearance irrespective of installation depth**
- > **For out-of-true installation offsetting up to 6° on each side**

## Technical description

### Applications:

Floor heating systems, wall heating systems

### Functions:

Individual room temperature control, Presetting, Shut-off, Venting

All Multibox 4 models are equipped with an additional supply shut-off incl. vent valve. Heating surfaces can be shut-off individually.

### Dimensions:

Valve body DN 15.

The flush box has an overall depth of 60 mm.

Flexible mounting thanks to variable spacing between flush box and cover of up to 30 mm.

Through a capillary tube, the temperature sensor liquid of the thermostatic head acts on the bellows in the valve adaptor. There is therefore never any change in the appearance of the cover with thermostatic head – irrespective of the installation depth.

The cover can compensate for slanted mounting of the flush box of up to 6° on each side.

See also Dimensions.

### Pressure class:

PN 10

### Setting range:

Thermostatic head F: 6 °C to 28 °C

### Temperature:

Max. working temperature: 90°C

Min. working temperature: 2°C

For all Multibox models, ensure that the system supply temperature is suitable for setting up the floor heating system.

See also Information!

### Material:

Valve body: Corrosion resistant Gunmetal

O-rings: EPDM rubber

Valve disc: EPDM rubber

Return spring: Stainless steel

Valve insert: Brass,

PPS (polyphenylsulphide)

Spindle: Niro-steel spindle with double

O-ring sealing. The outer O-ring can be

replaced under pressure.

Plastic parts of ABS and PA.

Sensor element: Thermostatic head F

with liquid filled sensor.

### Surface treatment:

Cover and visible graduation cap in white RAL 9016.

### Marking:

TAH, flow direction arrows, II-Designation.

### Pipe connection:

Pipe-side G 3/4 adaptor with cone suitable for compression fittings for plastic, copper, precision steel and multi-layer pipe.

## Construction

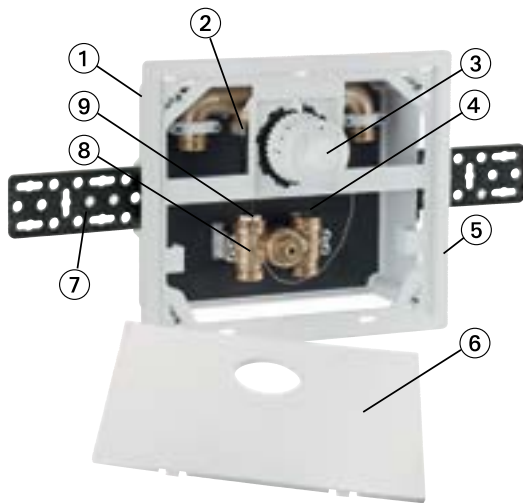

1. Flush box
2. Adaptor
3. Thermostatic head with capillary tube
4. Venting valve
5. Frame
6. Cover plate
7. Fixing bar
8. Valve body made of corrosion resistant gunmetal
9. Shut-off/regulating spindle

## Applications

### Multibox 4 F

Multibox 4 F is used for the individual room temperature control of, for instance, floor heating systems in association with low temperature heating systems.

Multibox 4 F is also used in wall heating systems.

Use the shut-off/regulating spindle for hydraulic balancing. For e. g. maintenance work, heating surfaces can be shut-off individually.

### Sample application

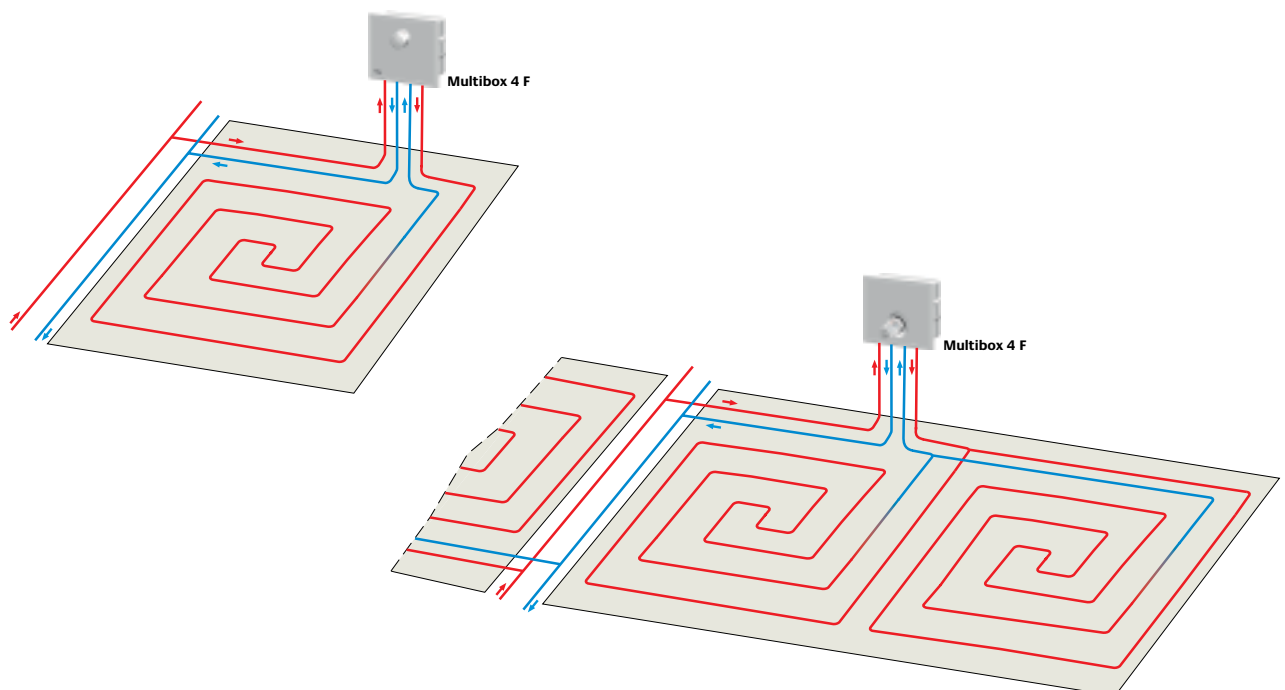

## Temperature setting

### Thermostatic head F

Cue number	*	1	)	2	3	4	5
Room temperature [°C]	6	12	14	16	20	24	27

## Function

### Multibox 4 F

From the control aspect, the thermostatic valve integrated in Multibox 4 F is a constant proportional controller (P-controller) without any auxiliary power. It does not need any electrical connection or other outside power source.

Change of the room air temperature (controlled variable) is proportional to the change of the valve lift (correcting variable).

A rise in the room air temperature e.g. from the sun's rays, results in an expansion of the liquid in the temperature sensor and it acts through the capillary tube on the bellows in the valve adaptor. By means of the valve spindle, this cuts back on the supply of water in the floor heating circuit. The procedure is reversed given a falling room air temperature.

## Articles

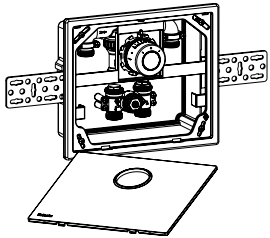

### Multibox 4 F with thermostatic valve

Colour	EAN	Article No
Cover and thermostatic head white RAL 9016	4024052766918	9316-00.800

## Information

### Planning

- **For all Multibox models, ensure that the system supply temperature is suitable for setting up the floor heating system.**
- **All Multibox models are to be connected to the return pipe at the end of the floor heating circuit. Heed direction of flow (see Examples of use).**
- Depending on piping pressure loss, all Multibox models are suitable for heating areas up to approx. 20 m<sup>2</sup>.
- The length of 12 mm internal diameter pipe in any heating circuit should not exceed 100 m.
- With heating areas >20 m<sup>2</sup> and/or pipe lengths >100 m, a T-piece, for instance, should be used to connect two equally long heating circuits to the Multibox. (see Examples of use).
- To ensure low-noise system operation, differential pressure over the valve should not exceed 0.2 bar.
- The floor heating pipe is to be laid spirally in the flooring screed (see Examples of use).
- The set value of the RTL should not be below ambient temperature - otherwise it will not open.

### Thermal fluid

To stop any damage and scale in hot water heating systems, the composition of the thermal fluid is to conform to VDI Directive 2035. For industrial and longdistance energy systems, see applicable codes VdTÜV and 1466/AGFW FW 510. Mineral oil in the thermal fluid and/or all kinds of lubricants containing mineral oil lead to considerable swelling and, in most

cases, to the failure of EPDM seals.

When using nitrite-free antifreeze and anti-corrosive based on ethylene glycol, technical advice – especially on additive concentration – is to be taken from the anti-freeze/anti-corrosive manufacturer's documentation.

### Functional heating

Carry out functional heating of heating screed conforming to standards in keeping with EN 1264-4.

#### **Earliest start for functional heating:**

- Cement screed: 21 days after laying
- Anhydrite screed 7 days after laying

Begin 20 °C - 25 °C flow temperature and maintain for 3 days.

Then set maximum design temperature and maintain for 4 days. Flow temperature can be regulated by controlling the heat generator. Turn the protective cap anticlockwise to open valve or turn RTL head to Position 5.

Refer to the screed manufacturer's information!

#### **Do not exceed maximum floor temperature at the heating pipes:**

- Cement and anhydrite screed: 55 °C
- Poured asphalt screed: 45 °C
- according to screed manufacturer's technical advice!

**Technical data – Multibox 4 K and K-RTL**

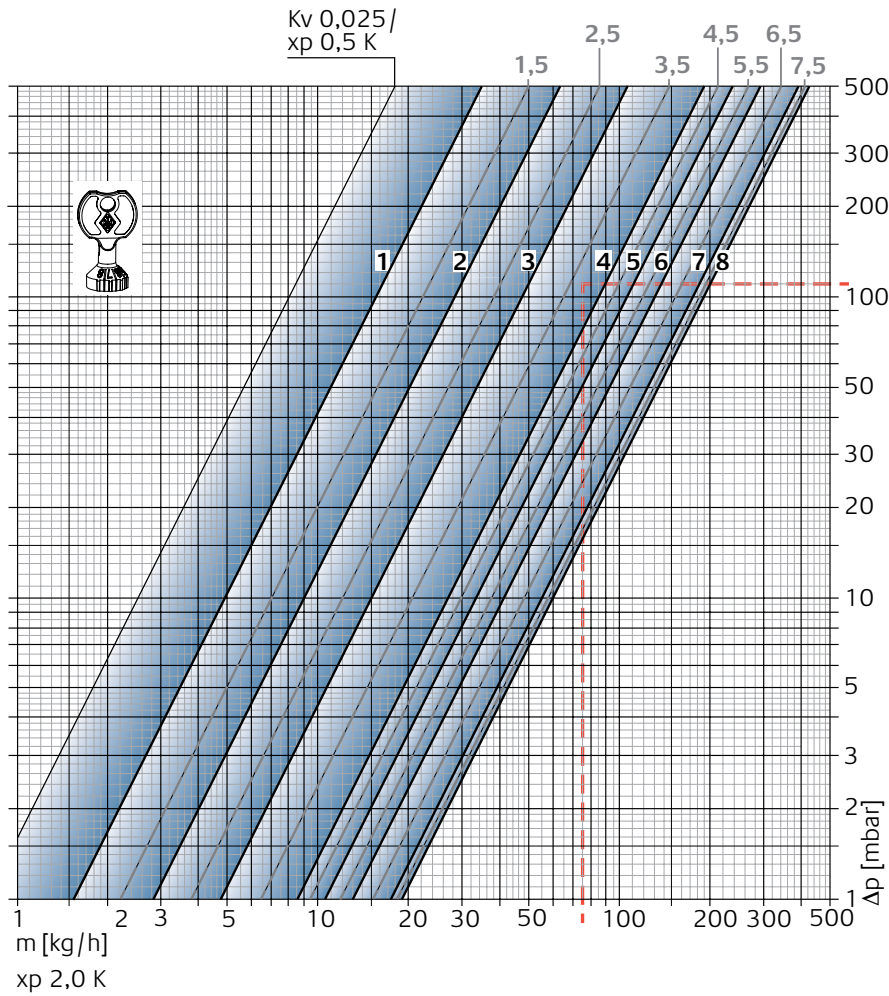

**Valve body with thermostatic head**

		Presetting							
		1	2	3	4	5	6	7	8
P-band [xp] <b>1.0K</b>	Kv-value	0,049	0,082	0,130	0,215	0,246	0,303	0,335	0,343
P-band [xp] <b>2.0K</b>	Kv-value	0,049	0,090	0,150	0,265	0,330	0,409	0,560	0,600
Kvs		0,049	0,102	0,185	0,313	0,332	0,518	0,619	0,670

Kv/Kvs = m<sup>3</sup>/h at a pressure drop of 1 bar.

**Sample calculation**

To be found:

Setting range

Given:

Heat flow Q = 1308 W

Temperature spread Δt = 15 K (65/50 °C)

Pressure loss Multibox 4 K, Multibox 4 K-RTL Δpv = 110 mbar

Solution:

Mass flow m = Q / (c · Δt) = 1308 / (1,163 · 15) = 75 kg/h

Setting range from Diagram:

With P-band **max. 2.0 K**: 4

$$Cv = \frac{Kv}{0,86}$$

$$Kv = Cv \cdot 0,86$$

## Technical data – Multibox 4 RTL

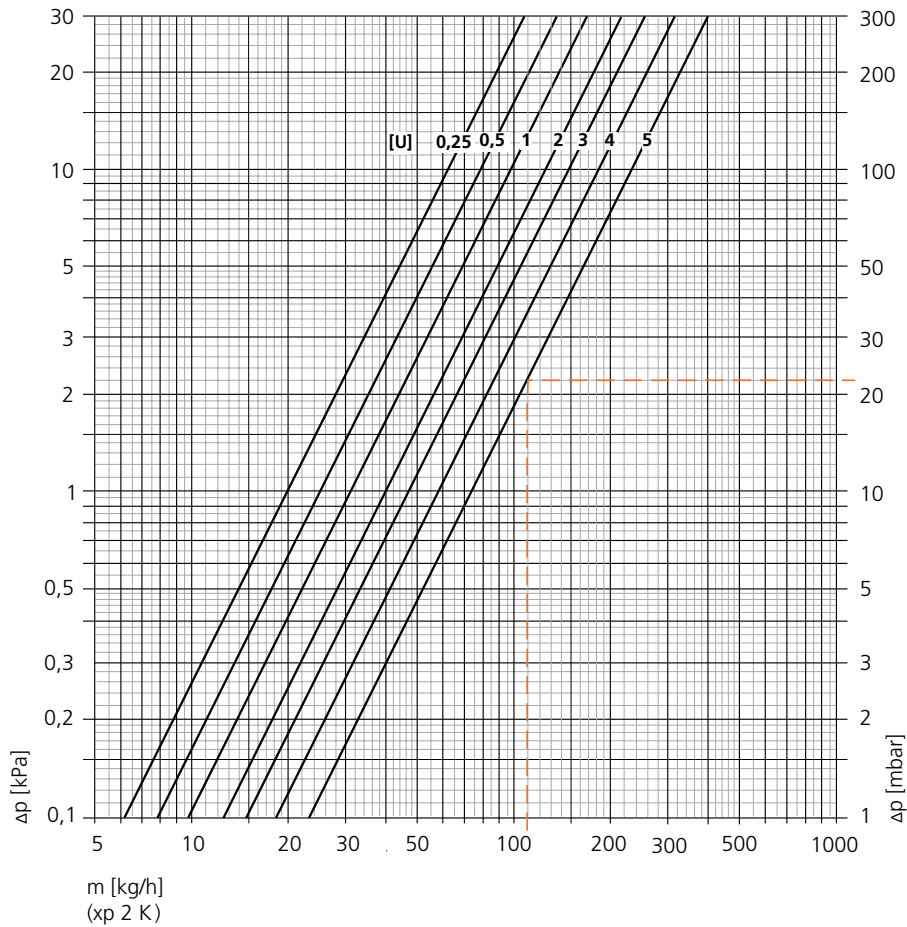

### Controller with valve body DN 15

Kv-value Multibox 4 RTL							Kvs
Preset rotations [U] Regulating spindle							
0,25	0,5	1,0	2,0	3,0	4,0	5,0	
0,20	0,25	0,31	0,40	0,47	0,58	0,74	

$K_v/K_{vs} = m^3/h$  at a pressure drop of 1 bar.

### Sample calculation

To be found:

Preset figure Multibox 4 RTL

Given:

Thermal flux  $Q = 1025 \text{ W}$

Temperature spread  $\Delta t = 8 \text{ K}$  (44/36° C)

Pressure loss Multibox 4 RTL  $\Delta p_v = 22 \text{ mbar}$

Solution:

Mass flow  $m = Q / (c \cdot \Delta t) = 1025 / (1,163 \cdot 8) = 110 \text{ kg/h}$

Preset figure from diagram: 5

$$C_v = \frac{K_v}{0,86}$$

$$K_v = C_v \cdot 0,86$$

## Technical data – Multibox 4 F

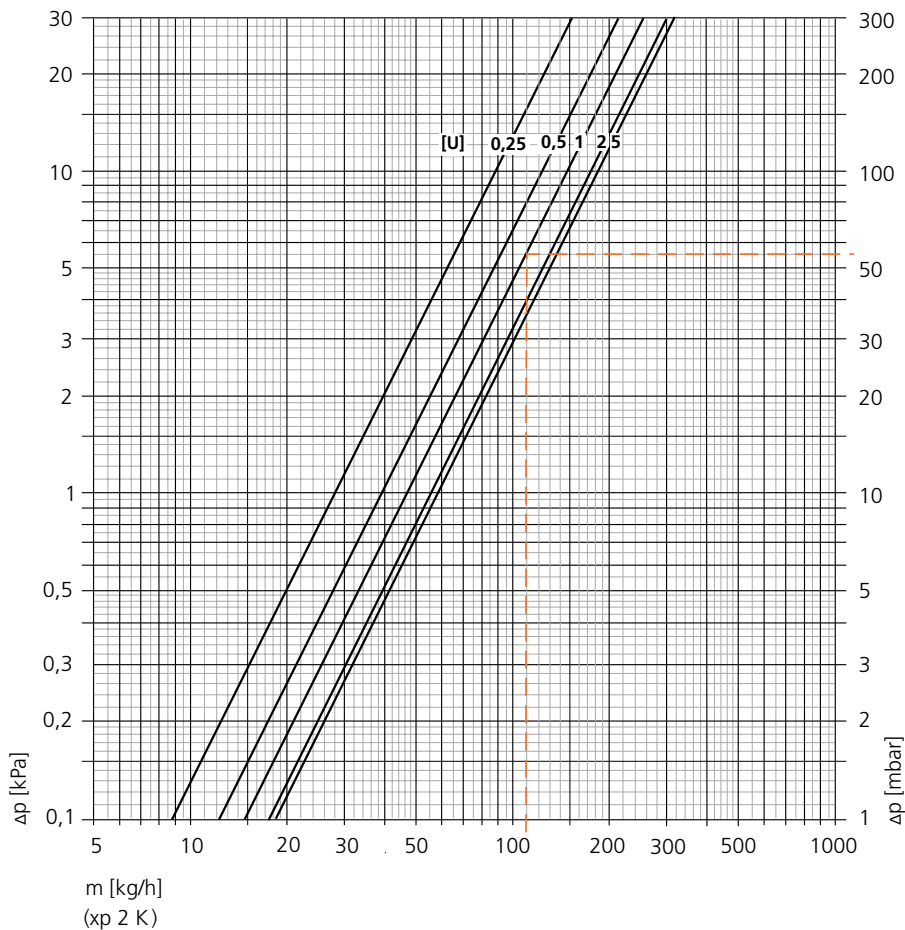

### Controller with valve body DN 15

P-band xp Th. head [K]	Kv-value Multibox 4 F							Kvs
	Preset rotations [U] regulating spindle							
	0,25	0,5	1,0	2,0	3,0	4,0	5,0	
1	0,25	0,32	0,35	0,38	0,39	0,40	0,41	0,74
2	0,28	0,39	0,47	0,56	0,57	0,58	0,59	

$Kv/Kvs = m^3/h$  at a pressure drop of 1 bar.

### Sample calculation

To be found:

Preset figure Multibox 4 F

Given:

Thermal flux  $Q = 1025 \text{ W}$

Temperature spread  $\Delta t = 8 \text{ K}$  (44/36° C)

Pressure loss  $\Delta p_v = 55 \text{ mbar}$

Solution:

Mass flow  $m = Q / (c \cdot \Delta t) = 1025 / (1,163 \cdot 8) = 110 \text{ kg/h}$

Preset figure from diagram: 1

$$Cv = \frac{Kv}{0,86}$$

$$Kv = Cv \cdot 0,86$$

## Accessories

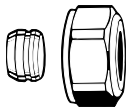

### Compression fitting

for copper or precision steel pipe.  
Brass nickel-plated.  
With a pipe wall thickness of 0.8-1 mm insert supporting sleeves. Heed pipe manufacturer's technical advice.

Ø Pipe	EAN	Article No
12	4024052214211	3831-12.351
15	4024052214617	3831-15.351
16	4024052214914	3831-16.351
18	4024052215218	3831-18.351



### Support sleeve

for copper or precision steel pipe with a 1 mm wall thickness.  
Brass.

Ø Pipe	L	EAN	Article No
12	25,0	4024052127016	1300-12.170
15	26,0	4024052127917	1300-15.170
16	26,3	4024052128419	1300-16.170
18	26,8	4024052128815	1300-18.170

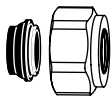

### Compression fitting

for copper or precision steel pipe.  
Brass nickel-plated.  
Soft sealed.

Ø Pipe	EAN	Article No
15	4024052515851	1313-15.351
18	4024052516056	1313-18.351

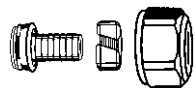

### Compression fitting

for plastic pipe.  
Brass nickel-plated.

Ø Pipe	EAN	Article No
14x2	4024052134618	1311-14.351
16x2	4024052134816	1311-16.351
17x2	4024052134915	1311-17.351
18x2	4024052135110	1311-18.351
20x2	4024052135318	1311-20.351



### Compression fitting

for multi-layer pipes.  
Nickel-plated brass.

Ø Pipe	EAN	Article No
16x2	4024052137312	1331-16.351

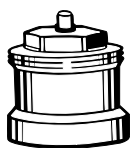

### Spindle extension for K thermostatic head with Multibox 4 K and Multibox 4 K-RTL

when maximum installation depth exceeded.

L	EAN	Article No
<b>Brass nickel-plated</b>		
20	4024052528813	2201-20.700
30	4024052528912	2201-30.700
<b>Plastic, black</b>		
15	4024052553310	2001-15.700
30	4024052165018	2002-30.700



### Spindle extension for RTL thermostatic head with Multibox 4 RTL

when maximum installation depth exceeded.  
Brass nickel-plated.

L	EAN	Article No
20	4024052500215	9153-20.700

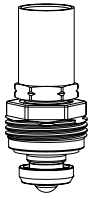

**Replacement insert for Multibox 4 RTL  
from 08.2013**

for valve bodies with II-marking.

EAN	Article No
4024052909711	1305-02.300

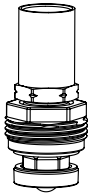

**Replacement insert for Multibox 4 RTL  
up to 08.2013**

EAN	Article No
4024052528714	9304-00.300

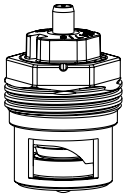

**V-exact II replacement insert for Multibox  
4 K and Multibox 4 K-RTL from 08.2013**

for valve bodies with II-marking.

EAN	Article No
4024052841417	3700-02.300

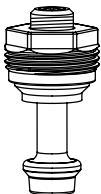

**Replacement insert with regulating  
spindle for Multibox 4 K, RTL, K-RTL**

for return valve.

EAN	Article No
4024052529018	9302-00.300

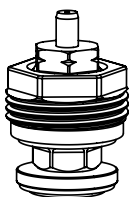

**Special insert for Multibox 4 K and  
Multibox 4 K-RTL up to 08.2013**

for reversed direction of flow with  
switched supply and return flow.

EAN	Article No
4024052492510	9302-03.300

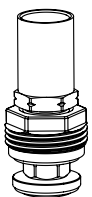

**Special insert for Multibox 4 RTL  
up to 08.2013**

for reversed direction of flow with  
switched supply and return flow.

EAN	Article No
4024052492619	9304-03.300

## Dimensions – Multibox 4 K, RTL, K-RTL

**Multibox 4 K**

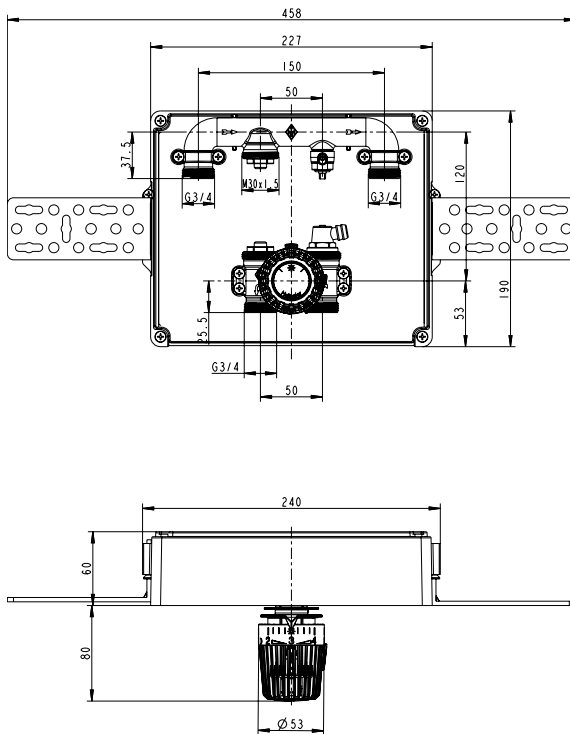

**Multibox 4 RTL**

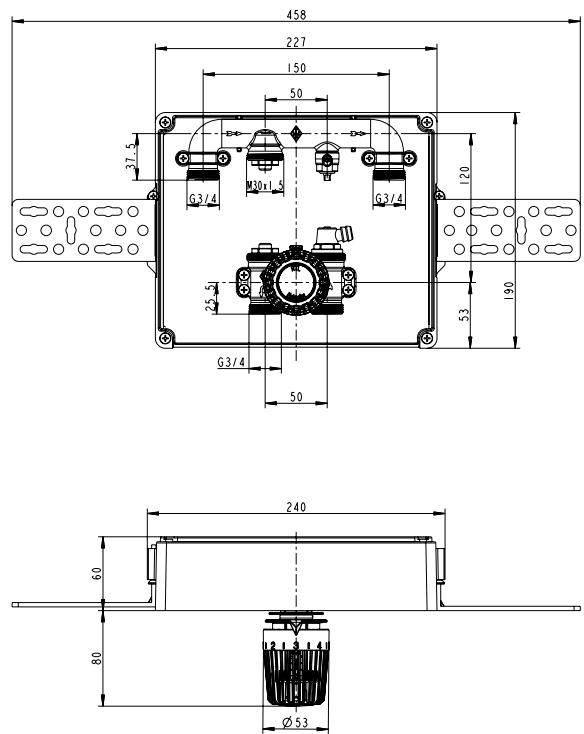

**Multibox 4 K-RTL**

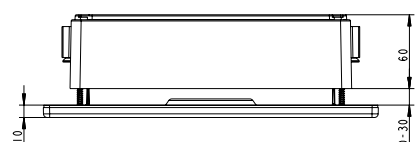
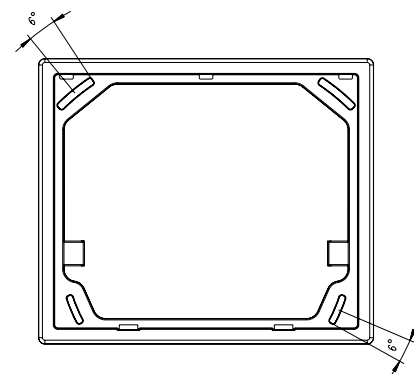
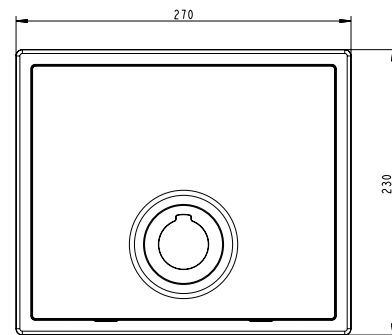
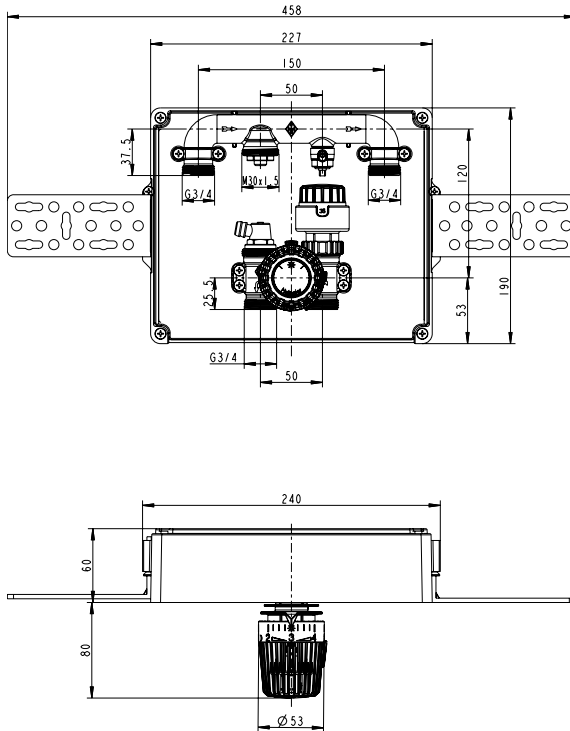

## Dimensions – Multibox 4 F

### Multibox 4 F

