

SPIROCOMBI® MB3

Effective system water deaeration
and dirt separation, combined in one unit



Industry-leading
20 year guarantee



Energy saving

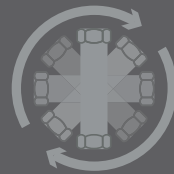

Quick and easy;
universal installation (360°)



Sturdy brass
housing



Highly efficient
air and dirt removal

SPIROCOMBI[®] MB3

Building on the proven success of our extensive range of high performance, high quality SpiroCombi deaerators/dirt separators, this latest generation of brass SpiroCombi MB3 has been designed to remove air, microbubbles and dirt particles from system water continuously.

SpiroCombi MB3 is a combined air and dirt separator. In a new system, the best position for the SpiroCombi MB3 is at the hottest point of the system, therefore installed in the flow from the boiler. When adding a SpiroCombi MB3 to an existing system, where there is potential for dirt and corrosion, the SpiroCombi MB3's preferred position would be in the return pipe to the boiler. Either way, rest assured the SpiroCombi MB3 will provide adequate protection from air and dirt.

PLACEMENT OF THE SPIROCOMBI MB3

The following instructions support heating engineers and installers in determining the best suitable placement of the SpiroCombi MB3 in the system.

Deaeration is generally seen as the key feature (high temperature) but, the locations of the unit can also be determined by the system circumstances. It is up to the engineer/installer (perhaps with guidance from the boiler manufacturer) to judge which location is best suited to the boiler/system.

For example: a completely new installation that has been properly flushed and inhibited, would benefit from positioning the combined unit on the flow side. A replacement boiler in an existing system that has been properly flushed and inhibited, would also benefit from positioning the combined unit in the flow pipe.

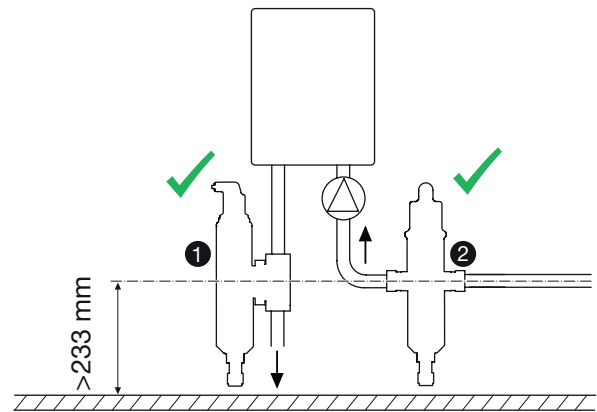

A dirty, problematic system would benefit from installing the combined unit in the return pipe, as close to the boiler as practically possible, or after the last tee connection in the return line. The small waterways in boilers do need consideration depending on system circumstances.

As a rule, air separators perform best on the temperature side of the boiler (position 1 in the diagram) while dirt separators provide optimal protection when placed in the return line (position 2 in the diagram) of the system, just before the pump.

SPIROCOMBI[®] MB3 Brass solution with magnet and universal connection

Article number	Connection	H (mm)	b (mm)	B (mm)	L (mm)	DØ	h	h1	e2	Nom. Flow rate (m³/h)	Nom. Flow rate (l/s)	Pressure drop @ 1 m/s (kPa)	Volume (kg)	Weight
UC022WJ	22 mm	272	123	141	120	84	123	149	R1/2	1.3	0,36	2.02	0.53	2.5
UC028WJ	28 mm	272	126	149	120	84	123	149	R1/2	2.0	0,55	3	0.55	3
UC075WJ	G¾	272	125	142	100	84	123	149	R1/2	1.3	0,36	2.02	0.36	2.5
UC0100WJ	G1	272	129	152	100	84	123	149	R1/2	2.0	0,55	3	0.55	3

x = >100 mm / y = >20 mm Fluid temperature 0 - 110°C Max. op. pressure 10 Nominal flow velocity 1 m/s

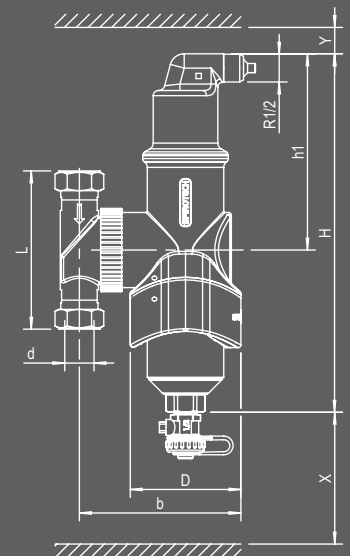

G10_462_00