

Intelligent Valve - Control valve with integrated energy measurement

EXG..EXF..



3-port control valve with integrated energy data acquisition for ventilation and air conditioning plants as well as precontrol circuits in HVAC applications. Sensor-guided dynamic flow control.

- Threaded valves EXG4U10A., DN15...50:
 - Nominal volume flow 1.2...12 m³/h
 - Externally threaded connection per ISO-228
- Flanged valves EXF4U20A., DN65...100:
 - Nominal volume flow 20...50 m³/h
 - Flange connection per ISO-7005
- System integration in building control technology over BACnet IP
- System integration in building automation and control over Modbus RTU
- Supports direct transfer to Siemens Operations Manager
- Ultrasonic volume flow measurement at measuring accuracy $\pm 2\%$ for water and $\pm 6\%$ for water-ethylene glycol mixtures
- Temperature measurement with paired immersion temperature sensors

Intelligent Valve is a 3-port pressure independent control valve (PICV) with volume flow, temperature, and power measurement, for heating, ventilation, and air conditioning plants. The valve can be integrated as analog (DC 0/2...10 V or 4...20 mA) or digital (BACnet IP / Modbus RTU) into the temperature control circuit. All process data (volume flow, power, primary flow and return temperature, etc.) can still be read out digitally, even if integrated as analog.

Intelligent Valve also has local limitation and optimization functions that support energy-efficient plant operation.

In addition to digital integration in the building automation and control system, integration in the cloud with the Siemens Operations Manager app supports the building operator in operating and monitoring the system, as well as evaluating energy consumption.

Intelligent Valve has the following control functions:

- Dynamic control valve
- Dynamic control valve (changeover)
- Flow temperature control
- Heating circuit outside temperature compensated flow temperature control

Volume flow limitation and energy acquisition are available at any time in all control functions.

Intelligent Valve as dynamic control valve

In this control function, Intelligent Valve is part of a temperature control circuit, and receives a setpoint from a superposed automation station that it interprets, depending on the control mode, as valve position, volume flow, or power, and control accordingly.

The example illustration depicts this based on a precontrol circuit for chilled ceilings.

Automation station [N1] controls the flow temperature of the chilled ceiling circuit by demand, and specifies the setpoint of 0...100 % on Intelligent Valve. This can occur in analog form (0...100 % = DC 0...10 V), or else remotely via BACnet IP or Modbus RTU.

Intelligent Valve follows this setpoint and sets, e.g. in volume flow control mode, the appropriate volume flow on port A.

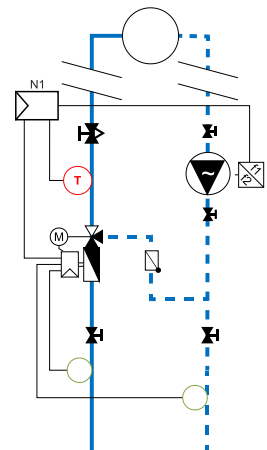

Intelligent Valve as dynamic control valve (changeover)

In this control function, Intelligent Valve acts as a dynamic control valve using 2 sets of parameters for the limitation functions, such as the maximum volume flow or the ΔT -limitation: one set for heating operation, and one set for cooling operation. The mode of operation (heating or cooling) is recognized automatically via the measured flow and return temperatures.

The example illustration depicts this based on a precontrol circuit for heated/chilled ceilings.

Automation station [N1] switches between heating and cooling mode as needed, and specifies the setpoint of 0...100 % on Intelligent Valve. Intelligent Valve follows this setpoint and sets the appropriate volume flow.

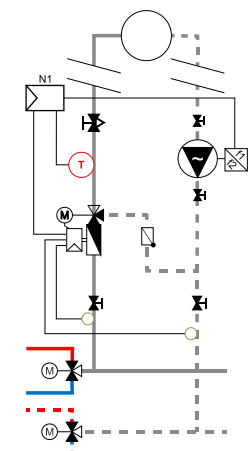

Intelligent Valve as flow temperature controller (*without outside air temperature sensor*)

In this control function, Intelligent Valve assumes the role of the automation station.

Using an auxiliary secondary flow temperature sensor [X3], it acquires the flow temperature and controls to the present temperature setpoint by adjusting the volume flow for ports A and B.

Possible sensor types at [X3] are passive sensors with sensing elements LG-Ni-1000, DIN-Ni-1000 or Pt1000 (385/EU).

The temperature setpoint can be preset externally via BACnet IP and Modbus RTU, or analog at [X1] (0...10 V = 0...100 °C).

The secondary pump is released by relay [Q1] as soon as the setpoint for secondary flow temperature is > 0 °C.

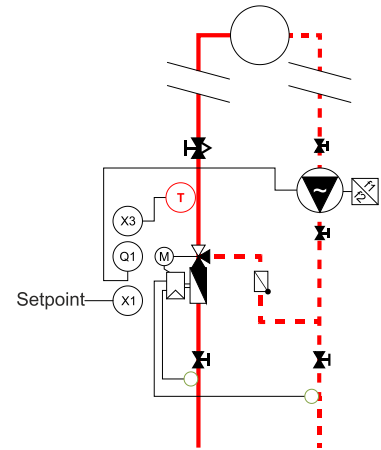

Intelligent Valve as outside temperature-dependent flow temperature controller

Intelligent Valve can control the valve in a heating group to a flow temperature based on the outside temperature. In this control function, Intelligent Valve assumes the role of the automation station.

In outside-temperature-dependent control, the flow temperature [X3] is assigned to the prevailing outside air temperature [X1] via the heating curve.

Possible sensor types at [X1] are passive sensors with sensing elements LG-Ni-1000, DIN-Ni-1000 or Pt1000 (385/EU), or active sensors (0...10 V = -50...50 °C).

The secondary flow temperature sensor [X3] acquires the present flow temperature and Intelligent Valve controls it to the determined flow temperature setpoint by adjusting the volume flow for ports A and B.

Possible sensor types at [X3] are passive sensors with sensing elements LG-Ni-1000, DIN-Ni-1000 or Pt1000 (385/EU).

In addition to the heating curve, a weekly time switch can also preset the room operating mode (Comfort, Pre-Comfort, Economy, Protection).

The heating curve and the weekly scheduler are set in ABT Go.

The heating circuit pump can be released or locked with relay [Q1].

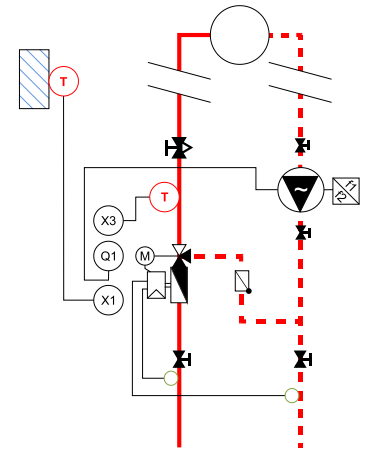

Every type of digital integration is available in every control function. Depending on the control function, there may be some restrictions:

	Dyn. control valve / Dyn. control valve (changeover)	Flow temperature control	Heating circuit outside temp. comp. flow temp. control
BACnet IP	Available		
Modbus RTU	Available		Available ¹⁾
Cloud	Available		

¹⁾ Possible with restricted functionalities. Cf. "Intelligent Valve - Modbus Registers" [A6V12547886] ("Product documentation [► 16]").

Basic design

Intelligent Valve combines the following main functions:

- Exact, continuous volume flow measurement with an ultrasonic flow sensor
- Precise temperature measurement using paired Pt1000 temperature sensors
- Precise volume control using a control valve with a high-resolution actuator
- Dynamic hydronic balancing, power and energy calculations, storage of cumulated flow and energy data, as well as network integration via a central control unit

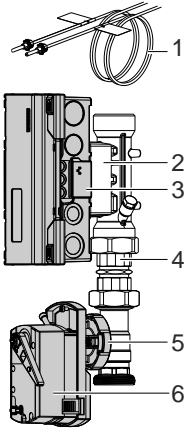
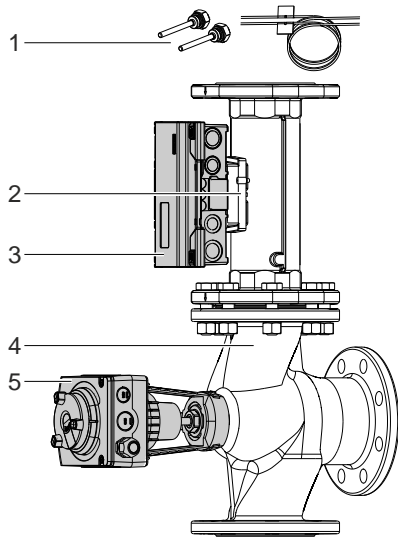
EXG4U10A..			EXF4U20A..		
	1	Temperature sensor pair (>DN50 with protective pockets)	1		
	2	Ultrasonic flow sensor	2		
	3	Intelligent Valve controller <ul style="list-style-type: none"> - Sensor interface - Dynamic volume flow control - Power and energy measurement - Heat exchanger optimized - Storage of cumulated flow and energy data - Network integration 	3		
	4	Flow sensor/valve interface	-		
	5	3-port valve <table border="1" style="width: 100%; border-collapse: collapse;"> <tr> <td style="width: 50%;">Ball valve</td> <td style="width: 50%;">Globe valve</td> </tr> </table>	Ball valve	Globe valve	4
	Ball valve	Globe valve			
6	High-resolution actuator	5			
					

The volume flow is acquired continuously in the ultrasonic flow sensor and provided to the Intelligent Valve controller. The controller applies it as the actual value for control or limitation by guiding the control valve position until the volume flow actual value for the applicable setpoint is achieved.

Control modes as dynamic control valve

Intelligent Valve supports 3 control modes in this control function:

- Volume flow control
- Position control
- Power control

Volume flow limitation is active in all control modes!

Volume flow control

In the basic configuration, Intelligent Valve operates as the flow controller on port A. This control mode is referred to as volume flow control.

The positioning signal is proportional to the volume flow of port A to be controlled (setpoint 0 % = closed; setpoint 100 % = \dot{V}_{100}). If a volume flow limitation is activated (\dot{V}_{min} and/or \dot{V}_{max}), the setpoint range reflects these new limitation values (setpoint 0 % = \dot{V}_{min} ; setpoint 100 % = \dot{V}_{max}).

It is not advisable to adapt the control characteristic on port A; accordingly, the control characteristic should remain on the factory setting "linear".

Position control

The control valve position is proportional to the setpoint (setpoint 0 % = closed; setpoint 100 % = H_{100}) - at the same time, the limitation to the applicable maximum volume flow (\dot{V}_{100} or \dot{V}_{max}) remains active.

Dynamic volume flow control is inactive in position control mode, and there is no electronic modification to the k_{VS} valve characteristic.

The k_{VS} valve characteristic is derived by combining the control (ball) valve characteristic and the resistance characteristic of the flow sensor.

This results in an equal percentage k_{VS} valve characteristic curve with a ngl 2.2 for valves EXG.. with a threaded connection (-----). The k_{VS} valve characteristic curve for flanged EXF.. valves is nearly linear (—————).

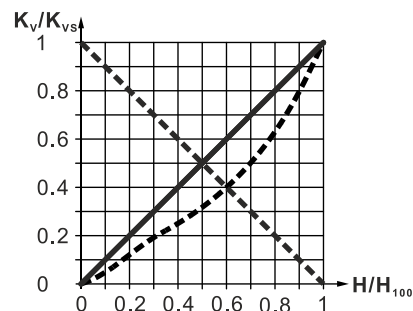

The characteristic curve in the through-port is linear (-----).

Power control

The design power is the reference variable. It is defined by:

- Design volume flow \dot{V}_{max}
- Design temperatures $T_{VL, design}$ and $T_{RL, design}$

Design power = $c \times$ design volume flow \times difference of the design temperatures

$$\dot{Q}_{design} \sim \dot{V}_{max} \times (T_{VL, design} - T_{RL, design})$$

whereby \dot{Q}_{max} is the power limitation in %, in relation to the design power of the consumption (heat exchanger/precontrol unit).

The setpoint for the control power is interpreted by referencing the power limitation ($Y = 0 \dots 100 \% \dot{Q}_{max}$; 0 % = closed; 100 % = \dot{Q}_{max}).

The section "Sizing [▶ 8]" provides a table of the power values for water at typical temperature spreads ("Sizing as dynamic control valve with water [▶ 8]").

The maximum volume flow limitation (\dot{V}_{100} or \dot{V}_{max}) remains active in power control mode as well (adapted maximum volume flow limitation is not available, see "Operating limitations and other features [▶ 5]").

The flow characteristic curve is not relevant to power control.

Operating limitations and other features

Nominal volume flow and minimum required differential pressure

Intelligent Valve has, like any dynamic control valve, a nominal flow \dot{V}_{100} by build design that cannot be exceeded during operation. A minimum differential pressure (Δp_{min}) is required to achieve nominal flow; it is calculated from the Intelligent Valve k_{VS} value.

In contrast to mechanical PICVs, the electronic volume flow control on Intelligent Valve remains active even below the minimum differential pressure - thus, the network is always optimally balanced.

Intelligent Valve supports several limitation functions:

- Maximum volume flow limit in port A
- Minimum volume flow limit in port A
- Maximum power limit
- Return temperature limitation (min./max. limitation)

- Temperature difference limitation between flow and return (ΔT -limitation)
- Weighted return temperature limitation
- Adapted maximum volume flow limitation
- Adapted maximum power limitation

Maximum volume flow limit

We recommend activating the maximum volume flow limitation, if the design volume flow for the part of the plant (heating coil/cooler/precontrol circuit) as controlled by Intelligent Valve, is lower than the nominal flow of the selected Intelligent Valve.

In volume flow control mode, the set volume flow \dot{V}_{\max} – which may be anywhere between 5...100 % of the nominal volume flow – is interpreted as the 100 % setpoint. It only serves as a limitation value in the other control modes.

Minimum volume flow limit

If a minimum flow through the controlled part of the plant is required, this can be achieved with the volume flow minimum limitation. The limitation is of course pressure-independent, so that there is no over- or under-supply as the local differential pressure changes.

Maximum power limit

In contrast to volume flow limitation, the power limitation adapts the flow rate dynamically to the temperature distribution in the plant. Consequently, power control is more suitable for critical users than volume flow limitation.

Min./max. return temperature limitation

Modern, high-efficiency power generators must have sufficiently low/high return temperatures to achieve their performance figures/degree of efficiency. With Intelligent Valve, you can precisely limit the return temperature value as needed by the given plant.

A maximum return temperature limitation is available if Intelligent Valve is used in heating applications; a return temperature minimum limitation is available in cooling applications.

The setting is made in 2 steps:

1. Enable the function
2. Set the limitation
 - Factory setting for maximum limitation = 40 °C
 - Factory setting for minimum limitation = 10 °C
 - Setting range = 0...100 °C

ΔT -limitation

In systems where the flow temperature cannot be maintained at a constant level – e.g. due to high load fluctuation or insufficient generator capacity – limiting the difference between the flow and return temperature is an alternative to absolute return temperature limitation. ΔT -limitation ensures that the consumer is not supplied with more power than the consumer can process.

The setting is made in 2 steps:

1. Enable the function
2. Set the limitation
 - Factory setting ΔT -limitation = 6 °C
 - Setting range = 0...40 °C

Weighted return temperature limitation

By enabling the weighted return temperature limitation, comfort is prioritized over energy efficiency, in contrast to the ΔT -limitation. For this function, a weighted return temperature setpoint is dynamically calculated, taking into account the design and actual flow values, as well as the design temperatures, both primary flow and primary return. A higher or lower return temperature will be allowed in order to ensure that comfort is prioritized and achieved.

The setting is made in 2 steps:

1. Enable the function
2. Set the limitation
 - Factory setting for design primary flow temperature = 55 °C
 - Factory setting for design primary return temperature = 40 °C
 - Setting range = 10...120 °C

Adapted maximum volume flow limitation

Enabling the adapted maximum volume flow limitation is a good idea in systems where the design volume flow and power in the part of the plant controlled by Intelligent Valve (heating coil/cooler/precontrol circuit) are unknown, or will regularly change in the future due to expansion of the plant or changes in use. This limitation avoids - both in the full and partial load range - short-term excessive volume flow demands from the controller, as can occur following sudden load fluctuations or switch-on processes.

The adapted maximum volume flow limitation functions as a moving maximum filter, and calculates the adapted maximum limitation value from the measured volume flow values of the last 4 days. Short-term increases are limited to this adapted maximum limitation value. Longer-term increases (lasting more than 3 hours) lead to a gradual upwards adjustment of the adapted maximum limitation value.

The function is only available in control mode "Volume flow". The setting is made by enabling the function. A setpoint is not needed.

Adapted maximum power limitation

Enabling the adapted maximum power limitation is a good idea in systems that are temperature sensitive, and where the design power in the part of the plant controlled by Intelligent Valve (heating coil/cooler/precontrol circuit) are unknown, or will regularly change in the future due to expansion of the plant or changes in use. This limitation allows for a linear heat transfer response at any load level with an adaptive maximum power value, meaning pressure- and temperature- independent control.

The adapted maximum power limitation functions as a moving maximum filter, and calculates the adapted maximum limitation value from the measured power values of the last 4 days. Short-term increases are limited to this adapted maximum limitation value. Longer-term increases (lasting more than 3 hours) lead to a gradual upwards adjustment of the adapted maximum limitation value.

The function is only available in control mode "Power". The setting is made by enabling the function. A setpoint is not needed.

Backup mode

The backup mode specifies the device behavior in case of loss of communication, cable breakage, or setpoint failure. If the setpoint is invalid for a configurable period of time, the backup mode determines the device's reaction.

This feature can be configured in 3 different ways:

- The valve is closed in backup mode.
- The device follows the last available setpoint.
- The device follows a predetermined setpoint.

As soon as a valid setpoint is available again, the backup mode stops.

Not all features are available to each control mode. Depending on the control mode, the following features are available:

	Dynamic control valve / Dynamic control valve (changeover)			Flow temperature control	Heat. circuit outside temp. comp. flow temp. control
	Position control	Volume flow control	Power control		
Setpoint	Building management system (BMS)			ABT Go and BMS	ABT Go
Maximum volume flow limit	Always active				
Minimum volume flow limit	Available				
Maximum power limit	-		Always active	Available	
Return temperature limitation	Available				
ΔT -limitation	Available				
Weighted return tem- perature limitation	Available				
Adapted max. volume flow limitation	-	Available	-	Available	
Adapted max. power limitation	-		Available		
Backup mode ¹⁾	Available				-

¹⁾ Only available for the setpoint sources "Analog (terminal)" and "Modbus RTU".

Mediums

Intelligent Valve can be used with all nominal sizes in hydronic circuits with chilled/hot water, as well as applications with water-ethylene glycol mixtures. A continuous range of maximum volume flow of 0.06...50 m³/h applies. The glycol concentration in the water-ethylene glycol mixtures must range between 20...50 %.

The lower concentration limit for water-ethylene glycol mixtures is due to the specifications by antifreeze manufacturers, which do not recommend a lower concentration.

For reliable volume flow/energy measurements of water-ethylene glycol mixtures, the concentration must be parameterized as accurately as possible (parameter "liquid concentration").

Sizing

Sizing as dynamic control valve with water

As a pressure-independent solution, it is generally easy to size Intelligent Valve. If the volume flow is an already known variable, simply select the corresponding valve plus - if desired - the suitable fittings from the diagram below. The electronic volume flow controller ensures that the valves always achieve the specified nominal volume flow. The nominal volume flow cannot however be exceeded.

Although a range of 5...100 % is permissible for the maximum volume flow \dot{V}_{max} , we recommend selecting the valves so that \dot{V}_{max} can be preset to a value of 30...90 %. This is to account for cases where a slightly higher or lower volume flow is required during operation than was originally calculated.

Maximum consumer power range at typical temperature spreads with water:							
Type	Stock number	DN	\dot{V}_{100}	\dot{Q} [kW] at			
			[m ³ /h]	ΔT 6 K	ΔT 10 K	ΔT 15 K	ΔT 20 K
EXG4U10A015	S55300-M150	15	1.2	8.4	13.9	20.9	27.8
EXG4U10A020	S55300-M151	20	2	13.9	23.2	34.8	49.4
EXG4U10A025	S55300-M152	25	3.2	22.3	37.1	56	74
EXG4U10A032	S55300-M153	32	5	34.8	58	87	116
EXG4U10A040	S55300-M154	40	8	56	93	139	186
EXG4U10A050	S55300-M155	50	12	70	116	174	232
EXF4U20A065	S55300-M156	65	20	139	232	348	464
EXF4U20A080	S55300-M157	80	32	223	371	557	742
EXF4U20A100	S55300-M158	100	50	348	580	870	1160

Sizing as dynamic control valve with ethylene glycol mixtures

Sizing Intelligent Valve for use with water-ethylene glycol mixtures is done analogously to sizing with water. If the volume flow is a known variable, simply select the corresponding valve plus - if desired - the suitable fittings from the diagram below.

We recommend selecting the valves so that the maximum volume flow \dot{V}_{max} must be preset to a value of 30...90 %.

Sizing as dynamic control valve - selection chart

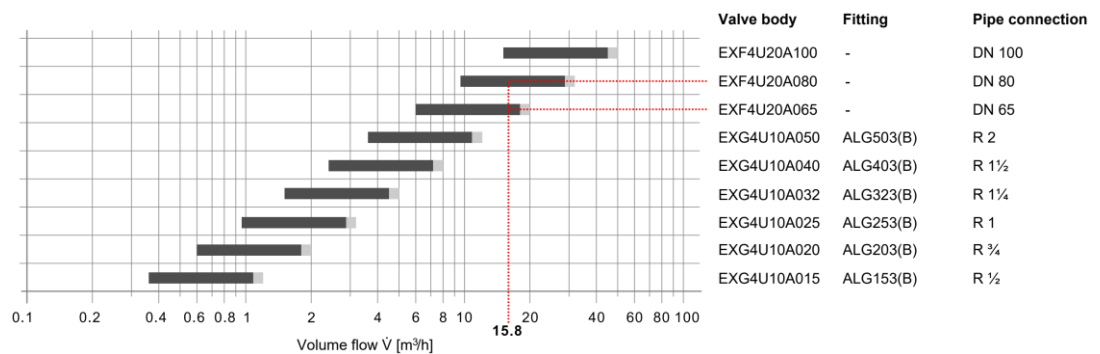

■ = Recommended design range that permits a subsequent increase in volume flow during the operation phase = 30...90 % of \dot{V}_{100}

■ = Maximum design range with no reserve to increase the volume flow = 90...100 % of \dot{V}_{100}

Example

Required volume flow \dot{V}_{max}	Intelligent Valve selection		
15.8 m ³ /h	EXF4U20A065:	\dot{V}_{100} = 20 m ³ /h	⇒ \dot{V}_{max} = 79 %
	EXF4U20A080:	\dot{V}_{100} = 32 m ³ /h	⇒ \dot{V}_{max} = 49 %

Sizing as flow temperature controller

As a rule, the power for transmission in this control function is available at the indicated primary design temperatures as design variables.

This information can be used to calculate the required plant design volume flow which then influences the valve selection. See "Engineering example [▶ 10]".

Engineering example

Calculation basis

1. Determine heating or cooling demand \dot{Q} [kW].
2. Determine temperature spread ΔT [K].

3. Calculate volume flow:

$$\dot{V}[\text{m}^3/\text{h}] = \frac{Q[\text{kW}] \times 3600[\text{s}]}{4190[\text{kJ}/\text{kgK}] \times \Delta T[\text{K}]}$$

4. Select suitable Intelligent Valve EX..

Example

1.	Heating/cooling power	$\dot{Q} = 110 \text{ kW}$
2.	Temperature spread	$\Delta T = 6 \text{ K}$
3.	Volume flow $\dot{V}[\text{m}^3/\text{h}] = \frac{110 \text{ kW} \times 3600 \text{ s}}{4190 \text{ kJ}/\text{kgK} \times 6 \text{ K}} = 15.8 \text{ m}^3/\text{h}$ <i>Note: You can use the valve slider to determine volume flow.</i>	
4.1	Select EX.. Select Intelligent Valve to operate at 90 % of the nominal volume flow to allow for higher heating or cooling power as needed.	
	Selection:	EXF4U20A065 $\Delta p_{\min} = 8.5 \text{ kPa}$
		EXF4U20A080 $\Delta p_{\min} = 4 \text{ kPa}$
4.2	Evaluate presetting.	
	EXF4U20A065: $15.8 / 20 = 79 \%$	<i>Optimum selection</i>
	EXF4U20A080: $15.8 / 32 = 49 \%$	

Sizing diagram

To determine the pressure drop at the requested maximum volume flow, refer to the k_{vs} values in the Type summary [► 12].

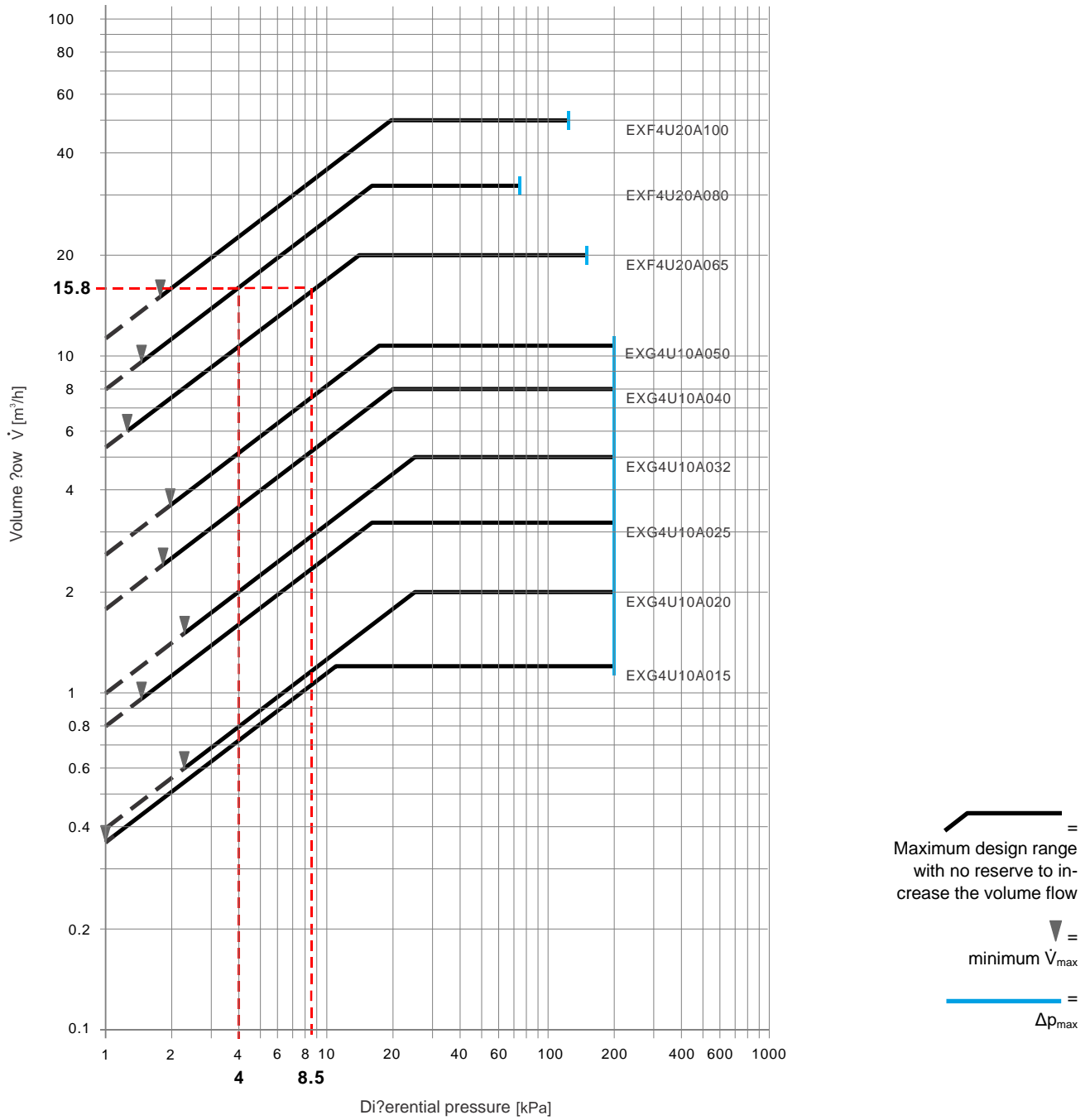

Calculated volume flow \dot{V}	Intelligent Valve selection	Differential pressure [kPa]
15.8 m³/h	EXF4U20A065	8.5
	EXF4U20A080	4

Threaded Intelligent Valve EXG4U10A..

Type	Stock number	DN	\dot{V}_{100}	$\min \dot{V}_{\max}$	Δp_{V100}	Δp_{V50}	Δp_{\max}	p_s	$k_{VS, A-AB}$	$k_{VS, B-AB}$
			[m ³ /h]	[kPa]	[kPa]	[kPa]	[kPa]	[m ³ /h]	[m ³ /h]	
EXG4U10A015	S55300-M150	15	1.2	0.06	11	3	200	1600	3.7	4
EXG4U10A020	S55300-M151	20	2	0.1	25	6			4	5
EXG4U10A025	S55300-M152	25	3.2	0.16	16	4			8	8
EXG4U10A032	S55300-M153	32	5	0.25	25	6			10	12
EXG4U10A040	S55300-M154	40	8	0.4	20	5			18	18
EXG4U10A050	S55300-M155	50	12	0.6	15	4			26	30

		Operating voltage	Positioning signal	Positioning time	Fail-safe function
EXG4U10A015	S55300-M150	AC / DC 24 V	DC 0...10 V DC 2...10 V 4...20 mA	90 s	-
EXG4U10A020	S55300-M151				
EXG4U10A025	S55300-M152				
EXG4U10A032	S55300-M153				
EXG4U10A040	S55300-M154				
EXG4U10A050	S55300-M155				

Flanged Intelligent Valve EXF4U20A..

Type	Stock number	DN	\dot{V}_{100}	$\min \dot{V}_{\max}$	Δp_{V100}	Δp_{V50}	Δp_{\max}	p_s	$k_{VS, A-AB}$	$k_{VS, B-AB}$
			[m ³ /h]	[kPa]	[kPa]	[kPa]	[kPa]	[m ³ /h]	[m ³ /h]	
EXF4U20A065	S55300-M156	65	20	1	14	3	150	1500	55	63
EXF4U20A080	S55300-M157	80	32	1.6	16	4	75	1200	80	100
EXF4U20A100	S55300-M158	100	50	2.5	19	5	125	1600	113	160

		Operating voltage	Positioning signal	Positioning time	Fail-safe function
EXF4U20A065	S55300-M156	AC / DC 24 V	DC 0...10 V DC 2...10 V 4...20 mA	30 s	-
EXF4U20A080	S55300-M157			120 s	
EXF4U20A100	S55300-M158				

- DN = Nominal size
- \dot{V}_{100} = Volume flow through a fully open valve
- $\min \dot{V}_{\max}$ = Minimum possible preset volume flow through a fully open valve
- Δp_{V100} = Minimum required differential pressure to guarantee nominal flow \dot{V}_{100}
- Δp_{V50} = Pressure drop over the fully opened valve at 50 % of nominal flow

- Δp_{max} = Maximum permissible differential pressure over the valve control path, valid for the entire positioning range of the valve-actuator unit
- p_s = Permissible operating pressure
- k_{vS} = Nominal flow value for water (5...30 °C) through a fully opened valve at a differential pressure of 100 kPa (1 bar)

Scope of delivery

Intelligent Valve is supplied as a complete set consisting of:

EXG.. Threaded	EXF.. Flanged
Intelligent Valve controller	
Actuator	
Flow sensor	
Control valve	
Mounting set	
Temperature sensor pair for direct installation (order protective pockets separately)	Temperature sensor pair including protective pockets

The devices are supplied without fittings, counterflanges, and gaskets.

Welding sleeves for protective pockets, such as WZT-G12, must be ordered separately!

Accessories / Spare parts

Accessories

Type	Stock number	Description	
EZT-M40	S55845-Z231	Protective pockets, brass, for DN15...50	DN65...125 already include protective pockets!
EZU-WA	S55845-Z234	Wall mount for Intelligent Valve controller	At high medium temperatures (>90 °C)
EZU-WB	S55845-Z236	Spacer for Intelligent Valve controller	Spacers, against risk of condensation due to low medium temperatures
ALJ100	S55846-Z115	Temperature adapter for ball valves	
ASZ6.6	S55845-Z108	Stem heating element for globe valves	At low medium temperatures (<0 °C)
EZU10-10060	S55845-Z237	Immersion temperature sensor pair Pt1000	PL Ø 6 x 105 mm, cable length 6 m
QAC22	BPZ:QAC22	LG-Ni1000 outdoor sensor	Temperature sensors for the control functions
QAD22	BPZ:QAD22	Strap-on temperature sensor LG Ni1000	
QAE2120.010	BPZ:QAE2120.010	Immersion temperature sensor LG Ni1000, with protection pocket, 100 mm	
QAE2120.015	BPZ:QAE2120.015	Immersion temperature sensor LG Ni1000, with protection pocket, 150 mm	
QAE2164.010	BPZ:QAE2164.010	Immersion temperature sensor DC 0...10 V, 100 mm	

Fittings

Type	Stock number	Description		
ALG153	BPZ:ALG153	G 1 " / Rp ½ "	Fittings sets of 3, for 3-port valves: <ul style="list-style-type: none"> • 3 cap nuts • 3 insert nuts • 3 flat seals 	Malleable cast iron
ALG203	BPZ:ALG203	G 1¼ " / Rp ¾ "		
ALG253	BPZ:ALG253	G 1½ " / Rp 1 "		
ALG323	BPZ:ALG323	G 2 " / Rp 1¼ "		
ALG403	BPZ:ALG403	G 2¼ " / Rp 1½ "		
ALG503	BPZ:ALG503	G 2¾ " / Rp 2 "		
ALG153B	S55846-Z101	G 1 " / Rp ½ "		Brass For medium temperatures up to 100 °C
ALG203B	S55846-Z103	G 1¼ " / Rp ¾ "		
ALG253B	S55846-Z105	G 1½ " / Rp 1 "		
ALG323B	S55846-Z107	G 2 " / Rp 1¼ "		
ALG403B	S55846-Z109	G 2¼ " / Rp 1½ "		
ALG503B	S55846-Z111	G 2¾ " / Rp 2 "		
ALR20.253B	S55845-Z275	R ¾ " / Rp 1 "	Reducers, set of 3	
ALR32.253B	S55845-Z276	R 1¼ " / Rp 1 "	Reducer nipples, set of 3	

Spare parts

Type	Stock number	Description	
ASE4U10A	S55845-Z320	Intelligent Valve controller for PICVs, series EXG4U10A.. and EXF4U20A.. without WLAN connection	
AVG4E015	S55845-Z206	Ultrasonic flow sensors, PN16	DN15, mounting length 110 mm, threaded, G ¾ B
AVG4E020	S55845-Z207		DN20, mounting length 130 mm, threaded, G 1 B
AVG4E025	S55845-Z208		DN25, mounting length 150 mm, threaded, G 1½ B
AVG4E032	S55845-Z209		DN32, mounting length 135 mm, threaded, G 1¼ B
AVG4E040	S55845-Z210		DN40, mounting length 200 mm, threaded, G 2 B
AVG4E050	S55845-Z212		DN50, mounting length 200 mm, threaded, G 2 B
AVF4E065	S55845-Z213		DN65, mounting length 300 mm, flanged
AVF4E080	S55845-Z214		DN80, mounting length 300 mm, flanged
AVF4E100	S55845-Z215		DN100, mounting length 360 mm, flanged
AVF4E125	S55845-Z216		DN125, mounting length 360 mm, flanged
ALG15G10B	S55846-Z135		Control valve mounting sets PN16
ALG20G15B	S55846-Z136	DN20, threaded	
ALG25G25B	S55846-Z137	DN25, threaded	
ALG32G20B	S55846-Z138	DN32, threaded	
ALG40G32B	S55846-Z139	DN40, threaded	
ALG50G32B	S55846-Z140	DN50, threaded	

Type	Stock number	Description	
ALF4E065	S55845-Z218		DN65, flanged
ALF4E080	S55845-Z219		DN80, flanged
ALF4E100	S55845-Z220		DN100, flanged
EZU10-2615	S55845-Z229	Temperature sensor pair Pt1000	DS M10x1, Ø 5.2 x 26 mm, cable length 1.5 m
EZU10-10025	S55845-Z230		PL Ø 6 x 105 mm, cable length 2.5 m
EZT-S100	S55845-Z232	Protective pocket G ½ B ", G ¼ B ", stainless steel, Ø 6.2 x 92.5 mm, for temperature sensors Ø 6 x 105 mm	
VBG61.15-6.3	S55230-V123	3-port control ball valves, externally threaded, PN40	DN15, k _{VS} 6.3
VBG61.20-6.3	S55230-V125		DN20, k _{VS} 6.3
VBG61.25-10	S55230-V126		DN25, k _{VS} 10
VBG61.32-16	S55230-V127		DN32, k _{VS} 16
VBG61.40-25	S55230-V128		DN40, k _{VS} 25
VBG61.50-40	S55230-V129		DN50, k _{VS} 40
VXF42.65-63	S55204-V139		3-port globe valves, flanged, PN16
VXF42.80-100	S55204-V141	DN80, k _{VS} 100	
VXF42.100-160	S55204-V143	DN100, k _{VS} 160	
GLA161.9E/HR	S55499-D444	Rotary actuator for ball valves, AC/DC 24 V, 10 Nm, NSR, modulating 0...10 V Highly accurate positioning signal, only for use with Intelligent Valve EXG4U10A..	
SAX61.03/HR	S55150-A142	Valve actuator 800 N, 20 mm stroke, AC/DC 24 V, modulating 0...10 V Highly accurate positioning signal, only for use with Intelligent Valve EXF4U20A.., DN65 and DN80	
SAV61.00/HR	S55150-A146	Valve actuator 1600 N, 40 mm stroke, AC/DC 24 V, modulating 0...10 V Highly accurate positioning signal, only for use with Intelligent Valve EXF4U20A.., DN100 and DN125	
428488060	BPZ:428488060	Stem sealing glands	For VXF42.65-63 and VXF42.80-100
467956290	BPZ:467956290		For VXF42.100-160

Product documentation

Title	Content	Document ID	
<i>Intelligent Valve - Control valve with integrated energy measurement</i>	<i>Data sheet: Product description EXG.., EXF..</i>	A6V13913365	
Rotary actuator for ball valves in combination with the Intelligent Valve controller	Data sheet: Product description GLA161.9E/HR	A6V11418678	
Electromotive actuators in combination with the Intelligent Valve controller	Data sheet: Product description SAX61.03/HR, SAV61.00/HR	A6V11418660	
Actuators SAX.., SAY.., SAV.., SAL.. for valves	Basic documentation: Comprehensive information on the new generation of SAX.., SAV.. actuators	P4040	
EVG../EXG../EVF../EXF..	Mounting instructions	A6V11449479	
GLA161.9E/HR	Mounting instructions	A6V11418688	
AVG4.., AVF4..	Mounting instructions	A6V11478285	
Intelligent Valve – Commissioning with ABT Go	Commissioning instructions: Step-by-step instructions how to configure and commission with ABT Go	A6V11422293	
Intelligent Valve – Engineering/Commissioning in Desigo	Engineering instructions: Step-by-step description of integration in Desigo PX plants	A6V11572317	
Intelligent Valve – BACnet Objects	List of BACnet objects for Intelligent Valve	A6V11757108	
Intelligent Valve – Modbus Registers	Description of Modbus registers for Intelligent Valve	A6V12547886	
Intelligent Valve – Onboarding in Building X Cloud	Engineering instructions: Step-by-step description of integration in Siemens Building X Cloud and Operations Manager	A6V11999683	
Intelligent Valve as dynamic control valve	Application description: Detailed description of configuration and functionalities for control function "Dynamic control valve"	A6V12191167	
Intelligent Valve as dynamic control valve (changeover)	Application description: Detailed description of configuration and functionalities for control function "Control valve for changeover"	A6V13443772	
Intelligent Valve as flow temperature controller	Application description: Detailed description of configuration and functionalities for control function "Flow temperature control"	A6V12191200	
Intelligent Valve as outside temperature-dependent flow temperature controller	Application description: Detailed description of configuration and functionalities for control function "Heating circuit outside temperature compensated flow temperature control"	A6V12191203	
Readme OSS "Intelligent Valve"	OSS document Open source software components, copyrights, licensing agreements	V1.2	A6V11676101
		V2.0	A6V12343374
		V3.0	A6V13095123
		V4.0	A6V14032035
		V5.0	A6V15968790

Related documents such as the environmental declarations, declarations of conformity, etc., can be downloaded from the following Internet address:

www.siemens.com/bt/download

Safety

⚠ CAUTION



National safety regulations

Failure to comply with national safety regulations may result in personal injury and property damage.

- Observe national provisions and comply with the appropriate safety regulations.

Qualified personnel

NOTICE



Qualified personnel!

Improper installation may override safety measures that a layperson may not recognize.

- Specialized knowledge of heating and air conditioning plants is required for installation.
- Only properly trained personnel may install the equipment.
- Prevent access to laypersons, especially children.

Only persons who can reasonably be expected to reliably conduct the work may actually perform the tasks. Do not permit persons whose reactions may be impaired, e.g. by drugs, alcohol, or medications, to perform the tasks.

Heating specialist

Heating specialists are persons who are capable of performing the mechanical work on heating and air conditioning plants and to independently recognize and avoid hazards due to their technical training, knowledge, and experience as well as their knowledge of applicable standards and regulations.

Heating specialists are specially trained for the work environment where they are active and know the relevant standards and regulations.

Engineering

Intelligent Valves EXG.. and EXF.. can be used in 3 types of hydronic circuit:

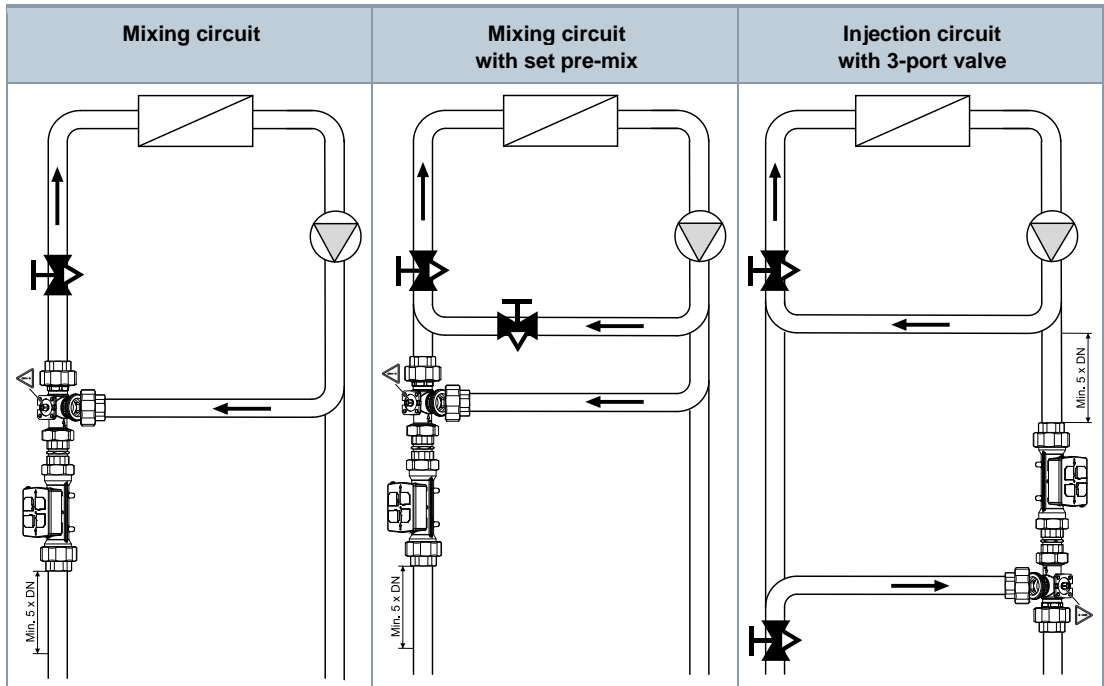

An unhindered inlet section of $L \geq 5 \times DN$ must be maintained upstream of the flow sensor to guarantee the indicated measurement and control accuracy.

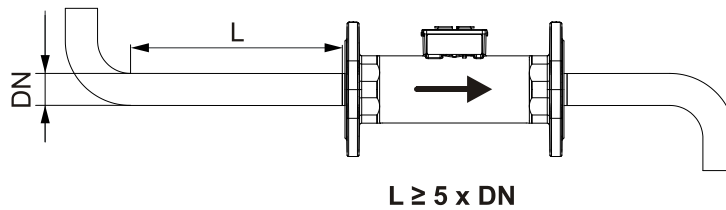

Symbol / flow direction EXG.. / EXF..	Flow in control mode		Valve stem	
	Inlet A / B	Outlet AB	Port A closes	Port A opens
	Variable		SAX.. / SAV.. Retracts	SAX.. / SAV.. Extends
			GLA.. Clockwise rotation	GLA.. Counterclockwise rotation



The indicated flow direction (arrow on the flow sensor and valve body) must be correct; Intelligent Valve cannot otherwise be operated!

Do not install it at the highest point on the partial plant since air bubbles may otherwise collect in the flow meter.

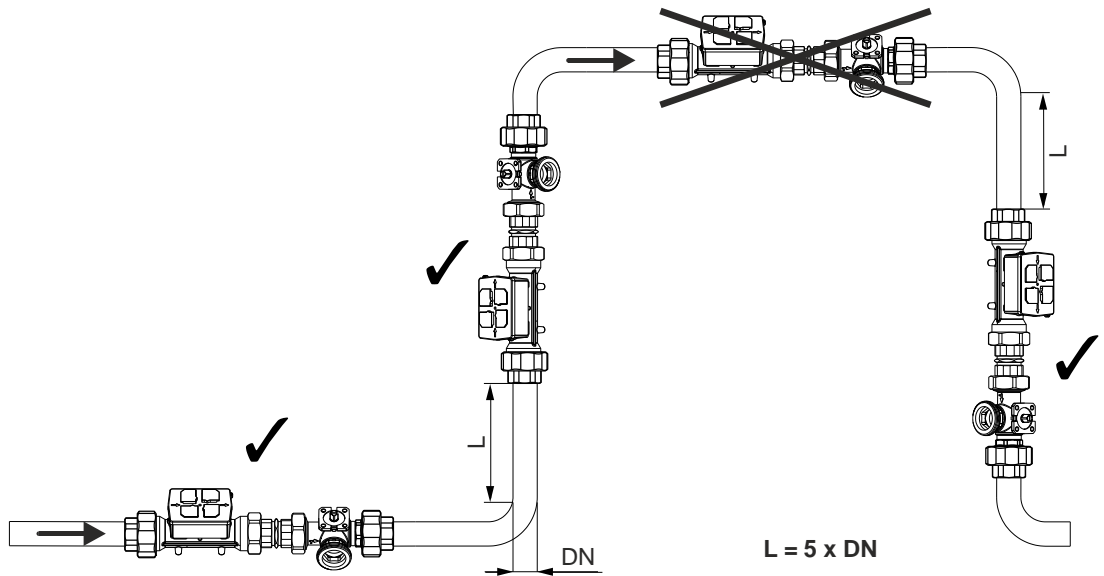

The rule is: *measure first, then control* – in other words, we recommend mounting the flow sensor upstream of the control valve in a compact installation.

Symbol in catalogs and application descriptions	Symbol in diagrams
	(There are no standard symbols for PICVs in the diagrams)

We recommend installing a filter or strainer in the flow upstream of the heat exchanger. This increases the reliability and life cycle of Intelligent Valve.

The flow sensor and control valve can be installed separately:

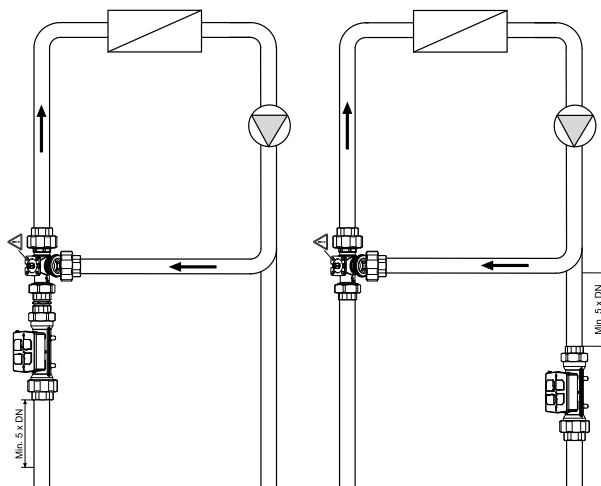

The actuator GLA161.9E/HR may only be used at medium temperatures $>0\text{ }^{\circ}\text{C}$.

If condensation occurs at the mounting site, the use of the temperature adapter ALJ100 as spacer is recommended in order to protect the actuator. If the medium temperature is $\leq 0\text{ }^{\circ}\text{C}$, the adapter shaft must be greased with silicon grease.

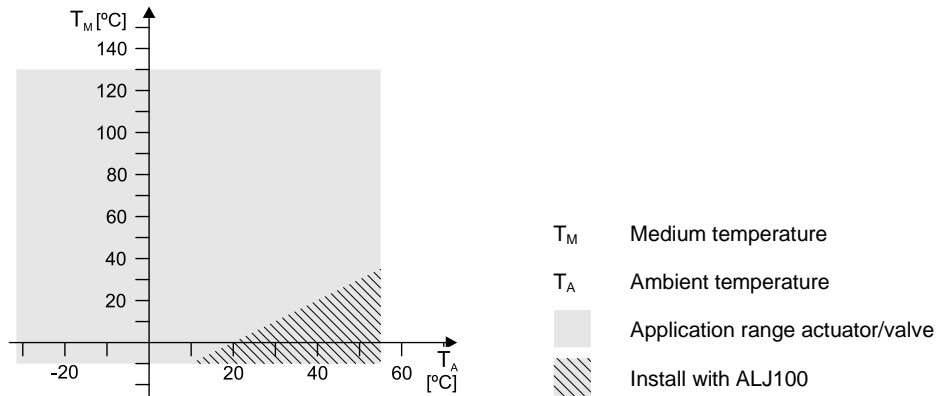

For actuators SAX61.03/HR and SAV61.00/HR, the use of the stem heating element ASZ6.6 is required with medium temperatures $< 0\text{ }^{\circ}\text{C}$, in order to prevent the valve from freezing.

⚠ WARNING



Risk of injury and fire from hot device parts

For media below $0\text{ }^{\circ}\text{C}$, the stem heating element ASZ6.6 keeps the valve stem ice-free. Lack of proper air circulation may lead to fire. Touching heated parts without safety measures leads to burns.

- The actuator and the valve stem must not be insulated in order to ensure air circulation.
- Ensure the stem heater is fully cooled down before touching it.
- For safety reasons, the stem heater is operated with AC 24 V / 30 W.

Mounting

Intelligent Valve is assembled at the mounting site. No adjustments, with the exception of configuring with the ABT Go app (see "Commissioning [▶ 22]") nor special tools are required.

Separate mounting instructions are included with the valve and flow sensor (see "Product documentation [▶ 16]").

Mounting positions

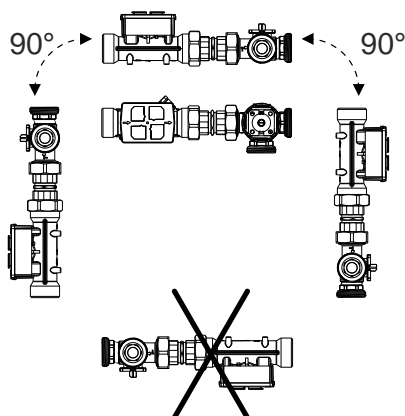

Mounting the controller

The controller can be mounted either onto the flow sensor or on the wall.

For the DN150 solution, the controller cannot be mounted onto the flow sensor. Wall mounting is recommended.

Mounting the flow sensor

Mount the flow sensor in the return if the media temperatures exceed 90 °C. If that is not possible, the Intelligent Valve controller must be mounted away from the flow sensor, using the wall-mount plate EZU-WA.

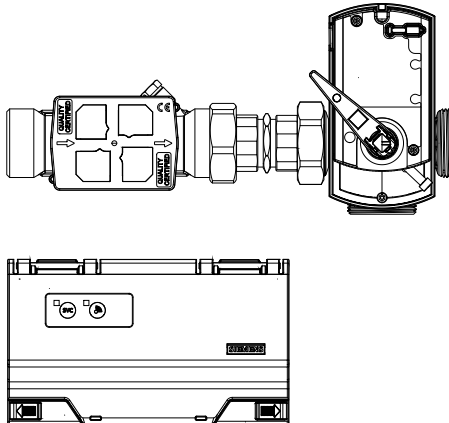

Mounting the temperature sensors

Threaded valves EXG4U10A..

The threaded valves are supplied with direct immersion temperature sensors EZU10-2615.

The sensors with the M10x1 threaded connection can be directly immersed in the flow sensor. In this case, the second temperature sensor is also directly immersed with the WZT-G10 welding sleeve (available as accessory).

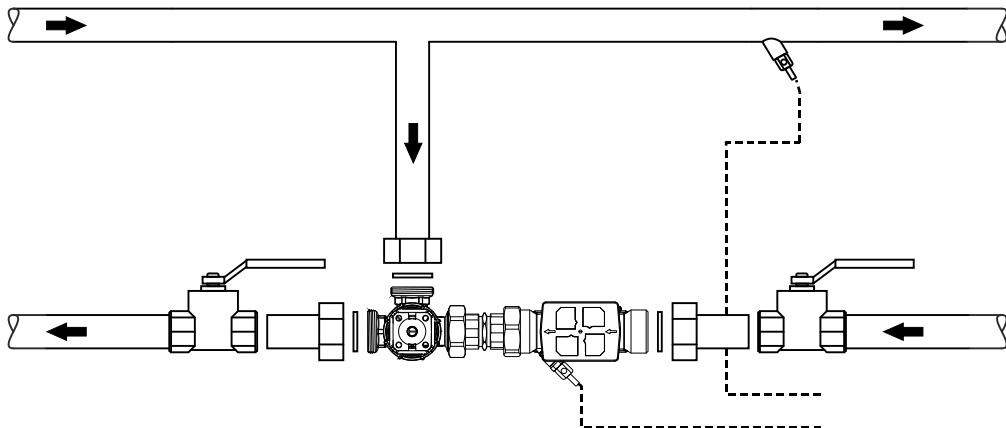

As an alternative, the sensors can be immersed directly in off-the-shelf ball valves with integrated measuring points (e.g. Siemens WZT-K.. / Jumo 902442/11) or t-pieces (e.g. Jumo 902442/31).

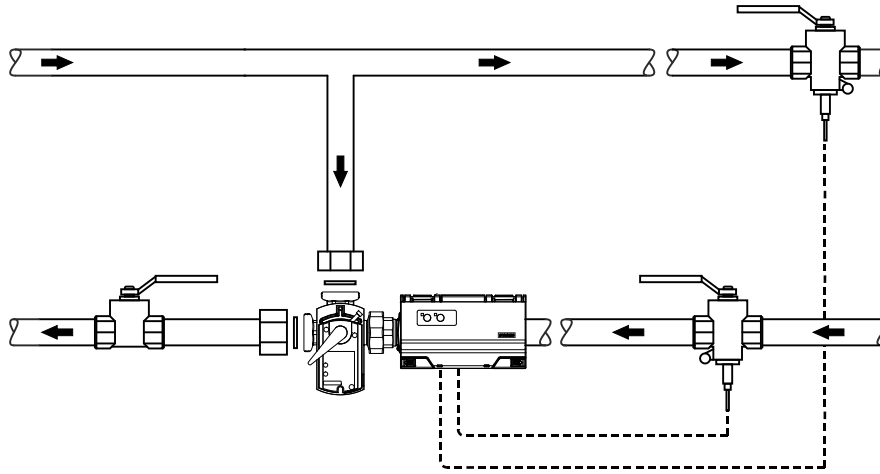

The brass protective pockets EZT-M40 are available for mounting with protective pockets.

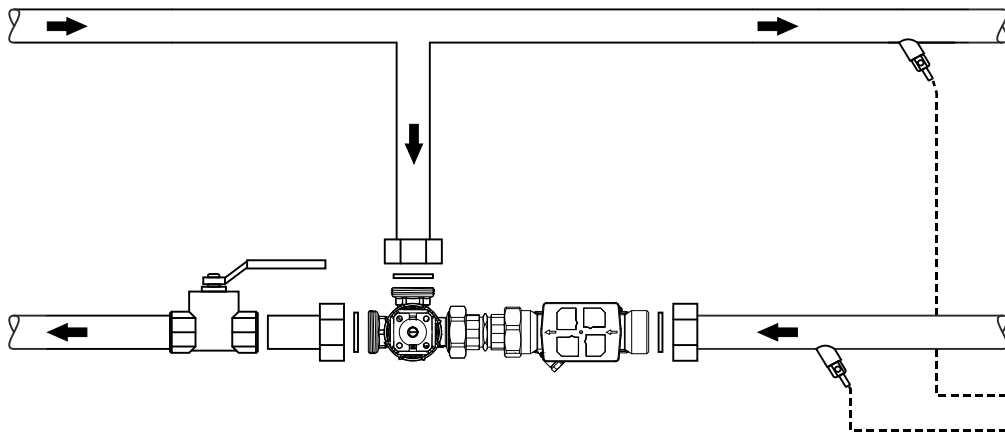

Flanged valves EXF4U20A..

The EXF.. flanged valves include the temperature sensors EZU10-10025 for installing in the protective pockets EZT-S100 (also included).

Welding sleeves must be planned on the construction side (e.g. WZT-G12) – installation example with protective pocket.

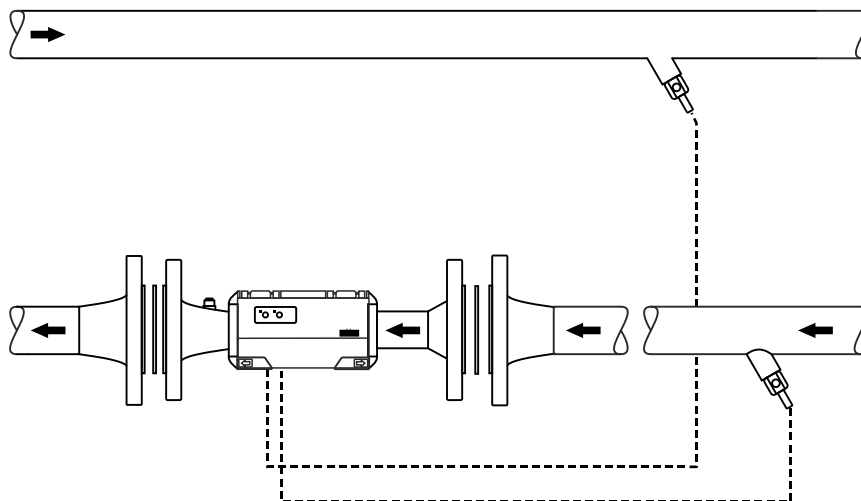

Commissioning

The device has only a simple user interface.

The Siemens ABT Go app is used to actually commission the device.

ABT Go App (Version 3.3.1 or later)

The Siemens ABT Go app is available in iOS and Android versions in the corresponding app stores, and can be used on smartphones and tablets. ABT Go supports network connection and USB connection. With the ABT Go for Windows, you can use your Windows laptop as an alternative to your smartphone.

The following are the most important setting parameters for commissioning Intelligent Valve:

Parameter	Value range	Description	Factory setting	Access level
Valve design	<ul style="list-style-type: none"> 2-port 3-port 	Selection whether a 2-port or 3-port valve is being controlled. <i>Must be set correctly to use 3-port valves EXG4U10A.. or EXF4U20A..!</i>	2-port	Measuring and control technician (MCT)
Control function	<ul style="list-style-type: none"> Dynamic control valve Control valve for changeover Flow temperature control Heating circuit outside temperature compensated flow temperature control 	See "Use [▶ 2]"	Dynamic control valve	MCT
Control mode	<ul style="list-style-type: none"> Position Volume flow Power 	See "Control modes as dynamic control valve [▶ 4]"	Volume flow	MCT
\dot{V}_{\max}	5...100 %	Maximum volume flow applicable to all control modes. Used for hydronic balancing of the consumer. Can be set in ABT Go in the units [m ³ /h], [l/h], [l/min], or [l/s].	Active 100 %	Installer
\dot{V}_{\min}	2.5...20 % Max.: \dot{V}_{\max} %	Minimum volume flow applicable to all control types. Cannot be greater than \dot{V}_{\max} . Can be set in ABT Go in the units [m ³ /h], [l/h], [l/min], or [l/s].	Inactive	Installer
Setpoint source	<ul style="list-style-type: none"> Analog (input X1) [terminal] Network (BACnet/IP) Network (Modbus RTU) 	Selection whether to interpret input X1 as the setpoint, whether it originates from a BACnet network or whether it is set locally to a fixed value via a Modbus register.	Analog (input X1)	MCT
Setpoint signal type	<ul style="list-style-type: none"> 0...10 V 2...10 V 4...20 mA 	Signal type applied to input X1	0...10 V	MCT
Actual value parameter	<ul style="list-style-type: none"> Position Volume flow Power Primary flow temperature Primary return temperature Temperature difference flow/return 	Selection of what the analog signal on output X2 represents. If "Volume flow" is selected: 0... \dot{V}_{100} = 0...100 %.	Deactivated	MCT
Actual value signal type	<ul style="list-style-type: none"> 0...10 V 2...10 V 4...20 mA 	Signal type applied to output X2	-	MCT
Flow characteristic	<ul style="list-style-type: none"> Linear Equal percentage Heat exchanger optimized 	The flow characteristic can be selected in the control mode "Volume flow".	Linear	MCT

User interface on the device

Service LED [1]

- Indicates the operating state (see table below)

Service button [2]

- Trigger wink
- Override setpoint and set \dot{V}_{\max} for 10 min (press for 3...6 s)
- Start flow test (press for 6...8 s)

Communication LED [3]

- Indicates the communication state (see table below)

Communication button [4]

- Used for trigger the reset

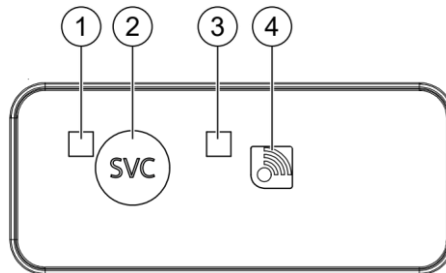

- Reset device to factory settings
 - Press and hold both buttons ([2], [4]) at the same time for 10...15 s: the LEDs ([1], [3]) slowly flash orange for 10 s
You can cancel the process during these 10 s by releasing the buttons.
 - After blinking for 10 s, the LEDs flash quickly for ca. 5 s and the reset is triggered by releasing the buttons.
 - The controller returns to normal operation without resetting if you continue to press the buttons until the flashing stops.

NOTICE



All configurations, network settings, commissioning parameters, and passwords are set to factory settings!

- This action cannot be cancelled nor reversed.

Service LED			SVC
Color	Blinking pattern		Description
	On	Off	
White	Steady	-	Device starting up
Green	0.5 s	0.5 s	Configuration mode
	4.75 s	0.25 s	Normal operation
	0.25 s	0.25 s	Stop local forced control
Blue	0.5 s	0.5 s	Local forced control – flow test
Yellow	0.5 s	0.5 s	Local forced control – continuous volume flow \dot{V}_{\max}
Red	0.5 s	0.5 s	Input/output or component fault: <ul style="list-style-type: none"> • Flow sensor <ul style="list-style-type: none"> – Wrong direction of flow – Air in sensor – Sensor connection faulty

Service LED			SVC
Color	Blinking pattern		Description
	On	Off	
			<ul style="list-style-type: none"> • Temperature sensors <ul style="list-style-type: none"> – Damaged cable – Short circuit • Actuator <ul style="list-style-type: none"> – Jammed – Faulty connection • Setpoint input terminal <ul style="list-style-type: none"> – Faulty connection – Signal invalid
	2 s / 5 Hz	- / 5 Hz	Flashing after wink command for physical device identification ¹⁾
	Steady	-	System fault
Orange	0.5 s	0.5 s	Reset to factory settings being prepared
	0.1 s	0.1 s	Reset to factory settings is triggered
-	-	-	Undervoltage

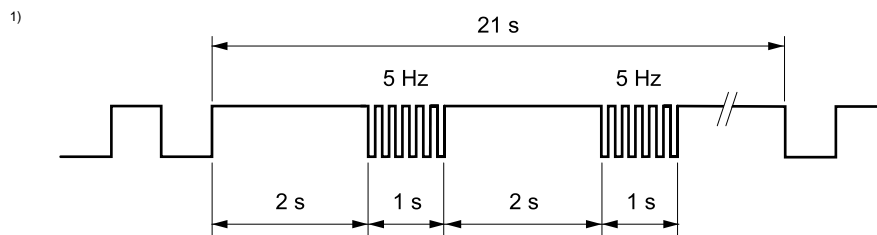

Communication LED			
Color	Blinking pattern		Description
	On	Off	
-	-	-	<ul style="list-style-type: none"> • No communication • Ethernet cable unplugged • Device starting up
Blue	0.1 s	0.1 s	No WLAN
Green	0.5 s	0.5 s	TCP/IP communication error – IP address not available
	Steady	-	TCP/IP data transmission ¹⁾
Purple	0.5 s	0.5 s	TCP/IP data transmission with Siemens Operations Manager (Cloud)
Orange	Steady	-	Modbus connected and configured – no data transmission via EIA-485
	0.5 s	0.5 s	Active communication via EIA-485
	0.5 s	0.5 s	Reset to factory settings being prepared ²⁾
	0.1 s	0.1 s	Reset to factory settings is triggered

- 1) With a daisy chain layout, it is only possible to check if a neighbor device is connected – the chain to the switch/router is not ensured and may even be broken.
- 2) Applies only if SVC LED also flashes synchronously.

Network integration BACnet IP

Intelligent Valve can be integrated into a BACnet IP network via TCP/IP.

The device supports:

- Star topologies

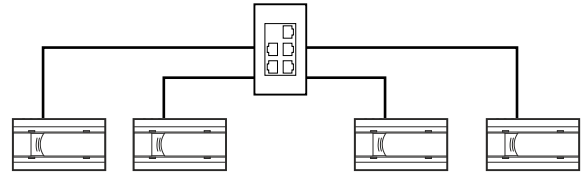

- Line topologies (daisy chain)

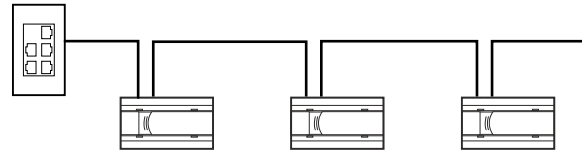

- Ring topologies

- Note here that network switches with "Rapid Spanning Tree Protocol (RSTP)" are used.

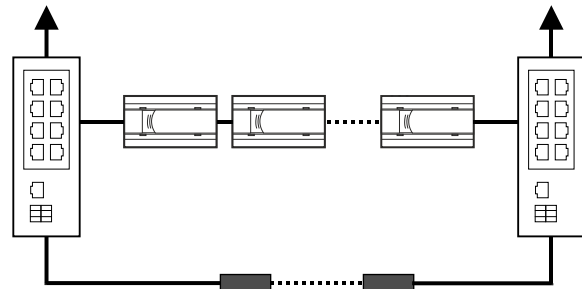

For daisy chains, it is recommended not to use more than 10 devices per chain.

A complete list of supported BACnet data points is included in the document "Intelligent Valve – BACnet Objects" (see "Product documentation [▶ 16]").

ABT Go app configures the network parameters (IP address, subsegment, etc.).

Network integration Modbus RTU

Intelligent Valve can be integrated into a Modbus RTU network via EIA-485. Although the RS485 standard is simple and well-proven in principle, there are important requirements and experience must be taken into account. This starts with choosing the appropriate topology:

- Best: Individual line
 - The best topology is a single line (line topology) with the bus cable connected directly to the individual devices (daisy chain). This type of connection has the fewest problems.

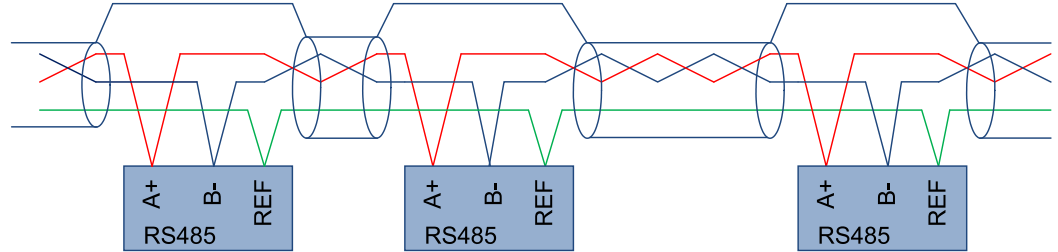

- Disadvantages of intermediate terminals
 - Connecting network devices via intermediate terminals and stub lines opens complicated paths for reflections and harmonics to the electrical signals. It is obvious that long and non-twisted intermediate lines increase the risk of interference.

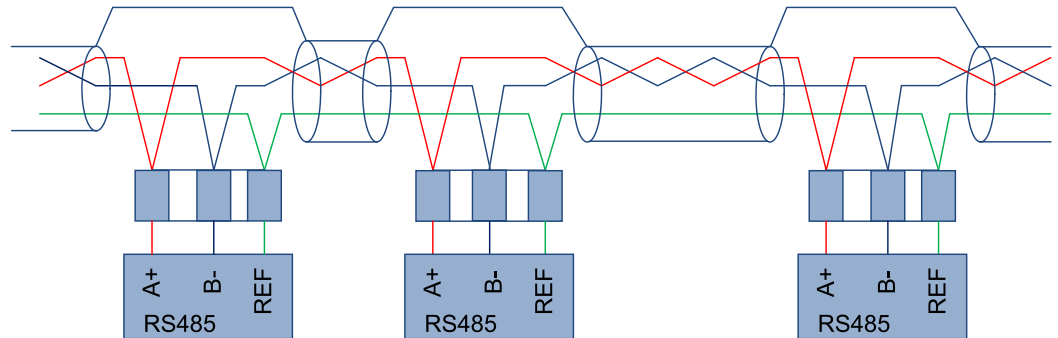

Maintenance

The control valves EXG.. and EXF.. are maintenance free.

Disposal



This symbol or any other national label indicates that the product, its packaging, and, where applicable, any batteries may not be disposed of as domestic waste. Delete all personal data and dispose of the item(s) at separate collection and recycling facilities in accordance with local and national legislation.

For additional details, refer to [Siemens information on disposal](#).

Intended use

⚠ WARNING	
	<p>Intended use</p> <p>Improper use can result in injury as well as damage to the product or plant.</p> <ul style="list-style-type: none"> • Siemens product may only be used with user cases set forth in the catalog and associated technical documentation. • User-related technical data are only guaranteed in connection with the products listed in this document. Siemens rejects any and all warranties in the event that third-party products are used. • Trouble-free and safe product operation presupposes transport, storage, setup, mounting, installation, commissioning, operation, and servicing as intended. • You must comply with permissible ambient conditions. Comply with all notes in the associated documentation.

Exemption from liability

The content of this document was reviewed to ensure it matches the hardware and firmware described herein. Nevertheless, differences may occur so that we are unable to fully guarantee a complete match. The information provided in this document is reviewed on a regular basis and any required corrections are added to the next edition. We always welcome suggestions on how to improve documentation.

Open Source Software (OSS)

Software license overview

These devices use Open Source Software (OSS); see the OSS document on the specific controller type and VVS.

All Open Source Software components used in the product (including copyrights and licensing agreement) are available at <http://siemens.com/bt/download>.

Firmware version	OSS document		Controller
	Document ID	Title	
FW01.21.xxxxx	A6V15968790	Readme OSS "Intelligent Valve", V5.0 (FW1.21.10552 onwards)	ASE4U10A
	A6V14032035	Readme OSS "Intelligent Valve", V4.0	
FW01.20.xxxxx	A6V13095123	Readme OSS "Intelligent Valve", V3.0	
FW01.19.xxxxx			
FW01.18.xxxxx	A6V12343374	Readme OSS "Intelligent Valve", V2.0	
FW01.17.xxxxx			
FW01.16.xxxxx			
FW01.15.xxxxx			
FW01.14.xxxxx	A6V11676101	Readme OSS "Intelligent Valve", V1.2	
FW01.13.xxxxx			

Cyber security disclaimer

Siemens provides a portfolio of products, solutions, systems and services that includes security functions that support the secure operation of plants, systems, machines and networks. In the field of Building Technologies, this includes building automation and control, fire safety, security management as well as physical security systems.

In order to protect plants, systems, machines and networks against cyber threats, it is necessary to implement – and continuously maintain – a holistic, state-of-the-art security concept. Siemens' portfolio only forms one element of such a concept.

You are responsible for preventing unauthorized access to your plants, systems, machines and networks which should only be connected to an enterprise network or the internet if and to the extent such a connection is necessary and only when appropriate security measures (e.g. firewalls and/or network segmentation) are in place. Additionally, Siemens' guidance on appropriate security measures should be taken into account. For additional information, please contact your Siemens sales representative or visit the following website:

<https://www.siemens.com/global/en/products/automation/topic-areas/industrial-cybersecurity.html>.

Siemens' portfolio undergoes continuous development to make it more secure. Siemens strongly recommends that updates are applied as soon as they are available and that the latest versions are used. Use of versions that are no longer supported, and failure to apply the latest updates may increase your exposure to cyber threats. Siemens strongly recommends to comply with security advisories on the latest security threats, patches and other related measures, published, among others, under the following website:

<https://www.siemens.com/cert/> => 'Siemens Security Advisories'.

Dimensions and weight	
See "Dimensions [▶ 41]"	

Power supply		EXG4U10A..	EXF4U20A.. DN 65...80	EXF4U20A.. DN 100
Operating voltage		AC 24 V ~ ±20 % (19.2...28.8 V ~) / DC 24 V = ±20 % (19.2...28.8 V ⇒)		
Frequency		50/60 Hz		
Power consumption including connected field devices				
	Running	5 W	6.25 W	8 W
	Holding	2.7 W	3.5 W	3.5 W
	Sizing	8.5 VA	14 VA	16 VA
Power consumption ASE4U10A				
	Running	3.5 W		
	Holding	2 W		
	Sizing	6 VA (controller without actuator!)		
Internal fuse		Irreversible		
External fusing of supply line		<ul style="list-style-type: none"> • Slow-blow fuse 6...10 A • Circuit breaker: Max. 13 A, type B, C, D per EN 60898 • Power source with current limitation of max. 10 A 		
Accessory: Stem heating element ASZ6.6				
	Operating voltage	AC 24 V ~ / DC 24 V = (19.2...28.8 V)		
	Power consumption (at 50 Hz)	50 VA / 30 W		
	Inrush current (cold)	Max. 8.5 A (max. temperature 85 °C/185 °F)		

Interfaces		
Ethernet	Plugs	2 x RJ45, screened
	Interface type	100BASE-TX, IEEE 802.3 compatible
	Bit rate	10/100 Mbps, autosensing
	Protocol	BACnet over UDP/IP
USB (2.0)	Plug	Micro-B
	Data rate	1.5 Mbps and 12 Mbps
		No galvanic isolation to ground
L-bus	Baud rate	2.4 kBaud
	Bus power supply	10 mA
		Short-circuit proof: Protection against faulty wiring at max. AC 24 V

Modbus RTU interface		
Interface type		EIA-485, galvanically isolated
Baud rates		9.6 / 19.2 / 38.4 / 57.6 / 76.8 / 115.2 kBaud
	Factory setting	19.2 kBaud
Internal bus termination		120 Ω , switchable with ABT Go
Internal bus polarization		270 Ω / 270 Ω – NOT switchable!
Cabling		3-core cable - only inside building
	Length	Max. 1000 m (3300 ft)
	NOTE	The baud rate must be adapted to match the cable length.
Protection		Short-circuit proof: Protection against faulty wiring at AC 24 V
Maximum number of devices (nodes) in bus segment		31

Function data

Control valve		EXG4U10A..	EXF4U20A..
Nominal flow		See "Type summary [▶ 12]"	
Adjustable flow as [%] of \dot{V}_{100}		5...100 %	
Permissible media		<ul style="list-style-type: none"> Chilled and hot water Water with ethylene glycol \leq 50 % 	
Control accuracy	Water	\pm 5 %	
	Water with ethylene glycol	\pm 10 %	
Minimum controllable flow		1 % of \dot{V}_{100}	
Medium temperature	Water	1...120 °C	
	Water with ethylene glycol	-10...90 °C	
Operating pressure p_s		1600 kPa	See "Type summary [▶ 12]"
Differential pressure $\Delta p_{max} / \Delta p_s$		See "Type summary [▶ 12]"	
Flow characteristic curve	Control type "Volume flow control"	Linear	
Leakage rate	Throughport	Waterproof per EN 60534-4 L/1, improved class 4	0...0.03 % of k_{VS} value
	Bypass	<1 % of k_{VS} value	0.5...2 % of k_{VS} value
Mounting position		Upright to horizontal	
Valve body		Brass	Cast iron
Blank flange		-	
Valve stem / seat / ball		Brass	Stainless steel
Stem sealing gland		EPDM	

Actuator	EXG4U10A..	EXF4U20A.. DN65...80	EXF4U20A.. DN100
	GLA161.9E/HR	SAX61.03/HR	SAV61.00/HR
Positioning time (at the specified nominal stroke)	90 s	30 s	120 s
Positioning force	-	800 N	1600 N
Nominal torque	10 Nm	-	
Nominal rotational angle	90°		
Nominal stroke	-	20 mm	40 mm

Flow measurement		EXG4U10A..	EXF4U20A..
Measuring method		Ultrasonic	
Measuring accuracy	Water	$\pm 2\%$ (25...100 % of \dot{V}_{100})	
	Water with ethylene glycol	$\pm 6\%$ (25...100 % of \dot{V}_{100}) ¹⁾	
Minimum flow measurement		0.8 % of \dot{V}_{100}	
Material of measuring pipe	DN15...50	Brass	-
	DN65	-	Brass
	DN80		Nodular cast iron EN-GJS-500
	DN100		Brass
Cable length		2.5 m	5 m

¹⁾ Verified with Antifrogen® N by Clariant

Temperature measurement		EXG4U10A..	EXF4U20A..
Measuring accuracy	Absolute temp.	$\pm 0.6\text{ °C}$ at 20 °C $\pm 0.8\text{ °C}$ at 60 °C (Pt1000 EN 60751, class B)	
	Temp. difference	$\pm 0.2\text{ K}$ at $\Delta T = 20\text{ K}$	
Resolution		0.085 °C	
Type examination certificate module B according to MID		A0445/2112/2007	DE-06-MI004-PTB011
Direct immersion sensor		DS M10x1, Ø 5.2 x 26 mm, cable length 1.5 m	-
	Permissible operating press.	PN16	
	Housing	Stainless steel	
Protective pocket		G ½ B ", Ø 6.2 x 92.5 mm for temperature sensors Ø 6 x 105 mm	
	Permissible operating press.	PN25	
	Material	Brass	Stainless steel

Inputs

The inputs are protected against incorrect wiring AC/DC 24 V.

Setpoint input, analog (input X1) in control functions "Dynamic control valve" and "Control valve for changeover"			
Type	Range (over-range)	Resolution	Input resistance (R _{in})
AI 0...10 V	0...10 V (-1...11 V) DC 0...10 V = 0...100 %	1 mV	100 kΩ
AI 2...10 V	2...10 V (1...11 V) DC 2...10 V = 0...100 %	1 mV	100 kΩ
AI 4...20 mA	4...20 mA (0...20 mA) 4...20 mA = 0...100 %	2.3 μA	<460 Ω
Open connection: Negative voltage -3.1 V (line failure detection)			

Setpoint input, analog (input X1) in control function "Flow temperature control"			
Type	Range (over-range)	Resolution	Input resistance (R _{in})
AI 0...10 V	0...10 V (-1...11 V) DC 0...10 V = 0...100 °C	1 mV	100 kΩ
AI 2...10 V	2...10 V (1...11 V) DC 2...10 V = 0...100 °C	1 mV	100 kΩ
AI 4...20 mA	4...20 mA (0...20 mA) 4...20 mA = 0...100 °C	2.3 μA	<460 Ω
Open connection: Negative voltage -3.1 V (line failure detection)			

Signal input, analog (input X1) in control function "Heating circuit outside temperature compensated flow temperature control"			
Type	Range (over-range)	Resolution	Input resistance (R _{in})
AI Pt1000 (385/EU)		85 mK (CIOR -50...400 °C) 0.153 °F	
AI (LG-)Ni1000		55 mK 0.099 °F	
AI Ni1000 DIN		45 mK 0.081 °F	
AI 0...10 V	0...10 V (-1...11 V) DC 0...10 V = -50...50 °C	1 mV	100 kΩ

Actuator position feedback, analog (input U)			
Type	Range (over-range)	Resolution	Input resistance (R _{in})
AI 0...10 V	0...10 V (-1...11 V)	1 mV	100 kΩ
Open connection: Negative voltage -3.1 V (line failure detection)			

Temperature measurement for power measurement, analog (inputs B7, B26)		
Type	Range (over-range)	Resolution
AI Pt1000 (385/EU)	-40...150 °C (-45...160 °C) -40...302 °F (-49...320 °F)	85 mK 0.153 °F

Temperature measurement, analog (input X3) in control functions "Flow temperature control" and "Heating circuit outside temperature compensated flow temperature control"		
Type	Range (over-range)	Resolution
AI Pt1000 (385/EU)	-40...150 °C (-45...160 °C) -40...302 °F (-49...320 °F)	85 mK 0.153 °F
AI (LG-)Ni1000		55 mK 0.099 °F
AI Ni1000 DIN		45 mK 0.081 °F

Flow measurement, digital (input DU)
Only use the flow sensor specified in the datasheet.

Outputs

The outputs are protected against short circuiting and incorrect wiring AC/DC 24 V.

Position feedback, analog (output X2)			
Type	Range (over-range)	Resolution	Output current / output impedance
AO 0...10 V	0...10 V (0...10.5 V)	11 mV	Max. 1 mA
AO 2...10 V	2...10 V (1...10.5 V)	11 mV	Max. 1 mA
AO 4...20 mA	4...20 mA (0...20 mA)	22 µA	<650 Ω

Actuator signal output, analog (output Y)			
Type	Range (over-range)	Resolution	Output current
AO 0...10 V	0...10 V (0...10.5 V)	11 mV	Max. 1 mA

Switching output relay Q1 (connection terminals Q13, Q14)	
Type	Relay
Switching voltage	AC 24 V / DC 30 V
Permissible load current	100 mA

Supply for field devices (outputs V ≈)	
Output voltage	AC/DC 24 V
Permissible load current	10 A
Protection against overload	None

Conformity

Protection class	
Housing, vertical to horizontal installation (see "Mounting [▶ 20]")	IP54 as per EN 60529
Insulation class	As per EN 60730
	AC/DC 24 V III

Ambient conditions	
Operation	As per IEC 60721-3-3 (1994)
	Climatic conditions Class 3K5
	Mounting location Indoors (weather-protected)
	Temperature (general) -5...<55 °C
	Humidity (non-condensing) 5...95 % r.h.
Transportation	As per IEC 60721-3-2 (1994)
	Climatic conditions Class 2K3
	Temperature -25...70 °C
	Humidity <95 % r.h.
Storage	As per IEC 60721-3-1 (1994)
	Climatic conditions Class 1K5
	Temperature -5...55 °C
	Humidity 5...95 % r.h.
Max. media temperature on coupled valve	120 °C

Directives, standards and approvals ²⁾	
EU conformity (CE)	
	EXG.. / EXF.. A5W00056027
	ASE4U10A A5W00055907
	AVG4E.. / AVF4E.. A5W00058665
	GLA161.9E/HR A5W00026945
	SAX61.03/HR 8000061818
	SAV61.03/HR 8000078918
	VXF42.. A5W00006523

Directives, standards and approvals ²⁾		
UK conformity (UKCA)		
	EXG.. / EXF..	A5W00221216A
	ASE4U10A	A5W00189149A
	AVG4E.. / AVF4E..	A5W00221215A
	GLA161.9E/HR	A5W00221282A
	SAX61.03/HR	A5W00185581A
	SAV61.03/HR	A5W00197822A
	VXF42..	A5W00276236A
RCM conformity		
	EXG.. / EXF..	A5W00056028
	ASE4U10A	A5W00055908
	AVG4E.. / AVF4E..	A5W00058666
	GLA161.9E/HR	A5W00026949
	SAX61.03/HR	8000074421
	SAV61.03/HR	8000078918
Product standard		IEC EN 60730-1
Electromagnetic compatibility (field of use)		For residential, commercial, and industrial environments
RoHS		2011/65/EU
BACnet	Conformance certificates (BTL, PICS)	https://www.bacnetinternational.net/btl

Environmental compatibility ²⁾		
The product environmental declarations below contain data on environmentally compatible product design and assessments (RoHS compliance, material composition, packaging, environmental benefit, and disposal).		
	ASE4U10A..	A5W00049332
	AVG4E..	A5W00261979
	AVF4E..	A5W00049465
	ALF4E..	A5W00049466
	GLA161.9E/HR	A5W00026068
	SAX61.03/HR	7173310559
	SAV61.03/HR	7173310522
	VXF42..	CE1E4403
	EZU10-..	A5W00049840
	EZT..	A5W00049841
	EZU-WA, EZU-WB	A5W00055673

²⁾ Documents can be downloaded at <http://www.siemens.com/bt/download>

Connection terminals

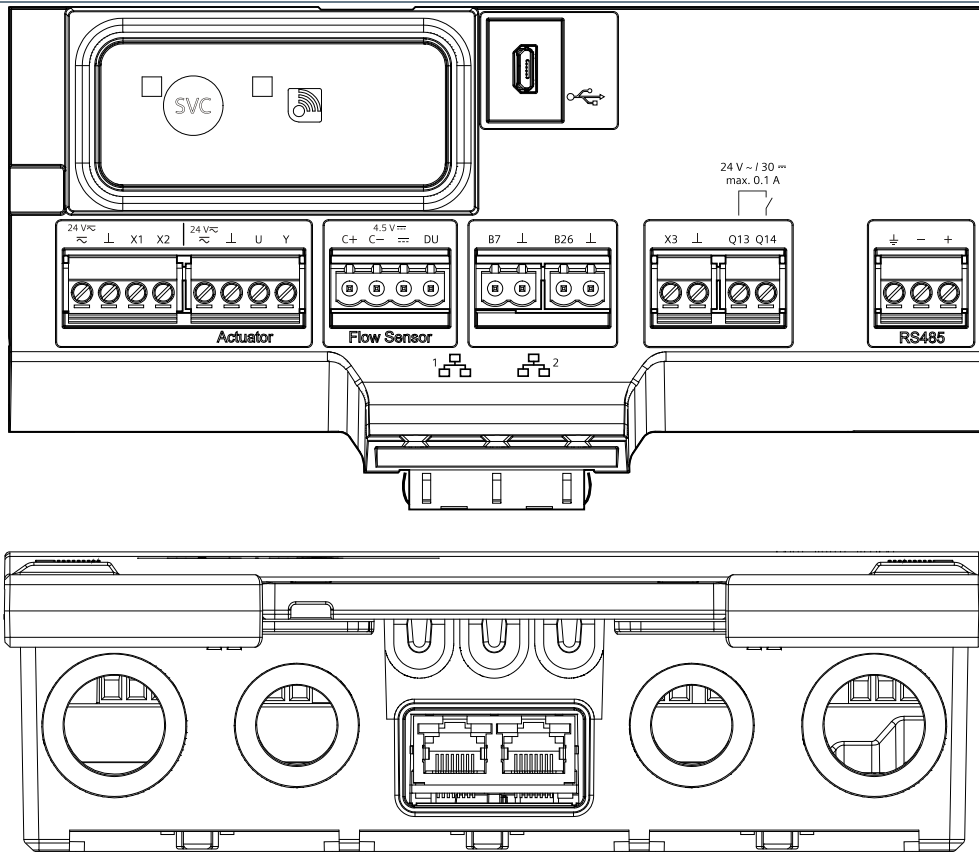

Connecting thread	Description	Terminal
1, 2 Ethernet	2 x RJ45 interface for 2-port Ethernet switch	
	Power SELV/PELV AC/DC 24 V	
	System zero	
	Setpoint input Intelligent Valve: DC 0/2...10 V; 4...20 mA <ul style="list-style-type: none"> Optionally (unless otherwise occupied): Active pressure sensor Control function "Heating circuit outside temperature compensated flow temperature control": Passive or active temperature sensor 	X1
	Actual value output Intelligent Valve: DC 0/2...10 V; 4...20 mA	X2
USB	USB interface	
Actuator	Field supply AC 24 V for actuator	
	System zero	
	Position feedback actuator DC 0...10 V	U
	Positioning signal actuator DC 0...10 V	Y
Flow sensor	L-bus potential	C+
	L-bus neutral (galvanically insulated)	C-
	Power flow sensor (DC 4.5 V)	
	Pulse input	DU
Inputs analog	Passive temperature input	B7

Connecting thread	Description	Terminal
	System zero	⊥
	Passive temperature input	B26
	System zero	⊥
	Universal input (DC 0/2...10 V; 4...20 mA / passive temperature input)	X3
	System zero	⊥
Outputs	Switching output AC 24 V; DC 30 V; 0.1 A	Q13
		Q14
RS485	EIA-485 interface (Modbus RTU) Supported from software version 1.18.xxxxx	⊥
		-
		+
Service	Service button	SVC
Display	Operation LED	
Communication	Communication button	📶
Display	Communication LED	📶

Connection diagrams

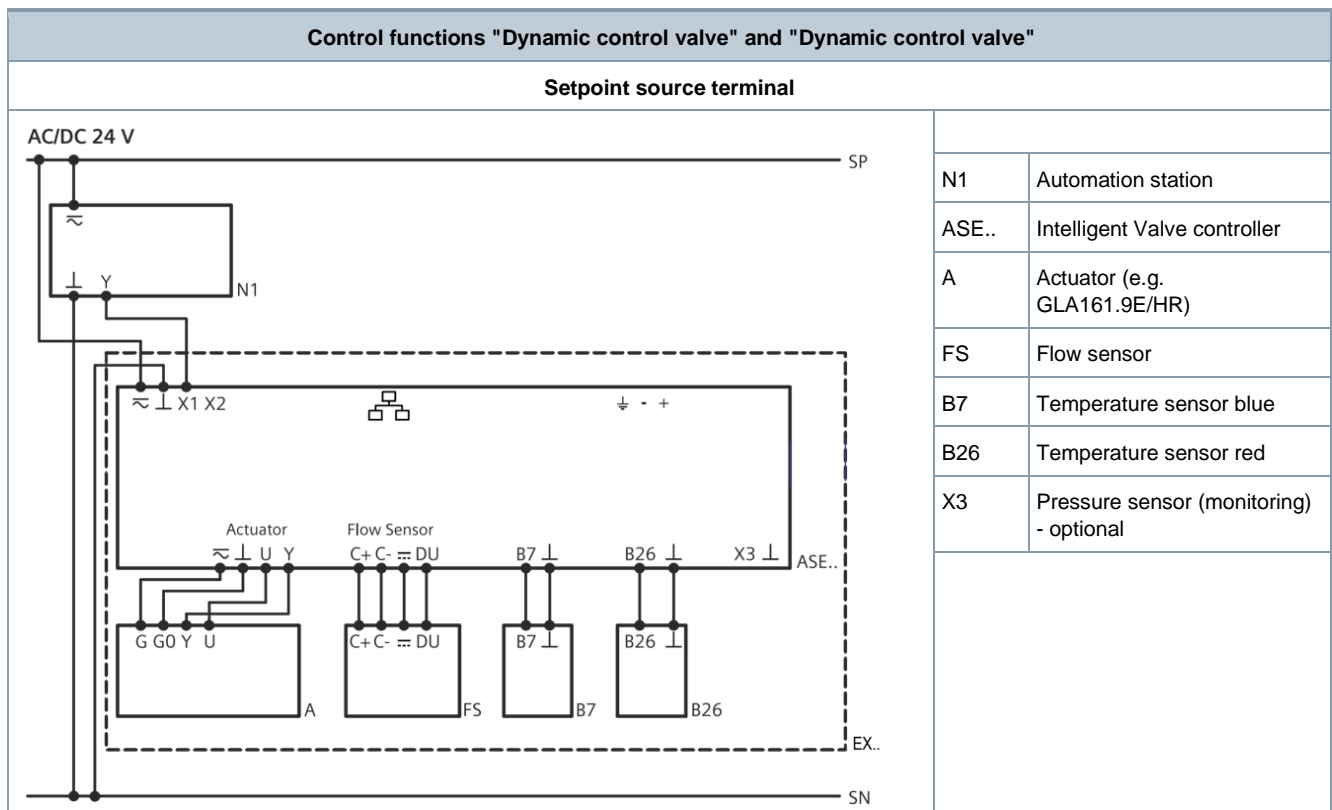

Setpoint source Modbus

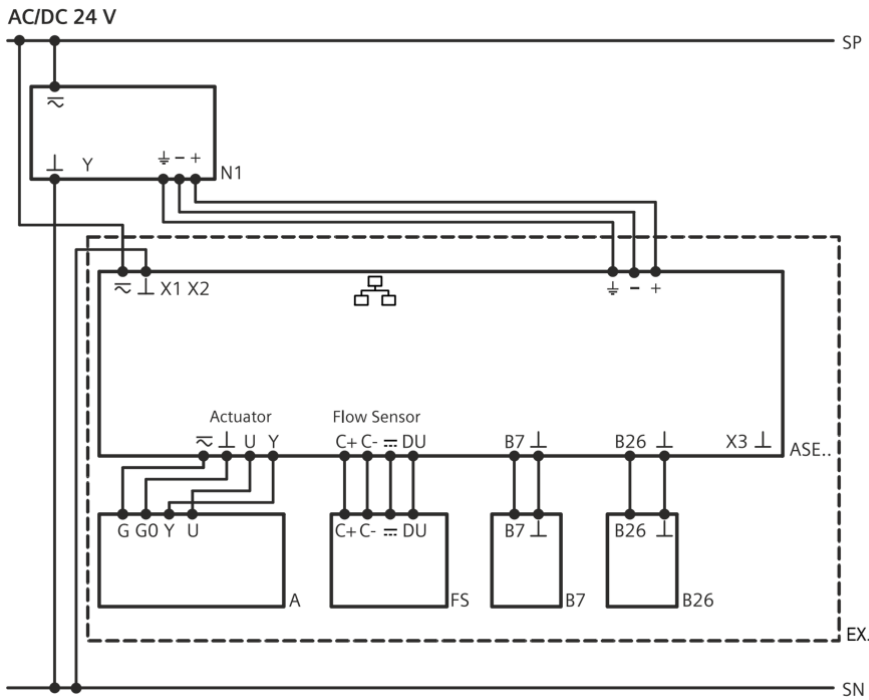

N1	Automation station
ASE..	Intelligent Valve controller
A	Actuator (e.g. GLA161.9E/HR)
FS	Flow sensor
B7	Temperature sensor blue
B26	Temperature sensor red
X1, X3	Pressure sensors (monitoring) - optional

Setpoint source BACnet

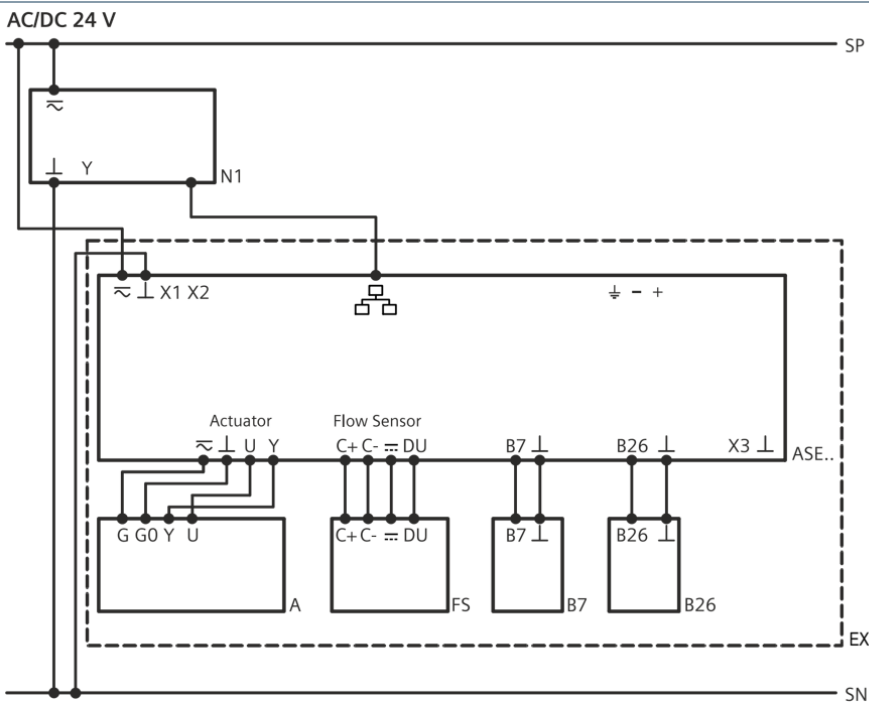

N1	Automation station
ASE..	Intelligent Valve controller
A	Actuator (e.g. GLA161.9E/HR)
FS	Flow sensor
B7	Temperature sensor blue
B26	Temperature sensor red
X1, X3	Pressure sensors (monitoring) - optional

Control function "Flow temperature control"

Setpoint source terminal

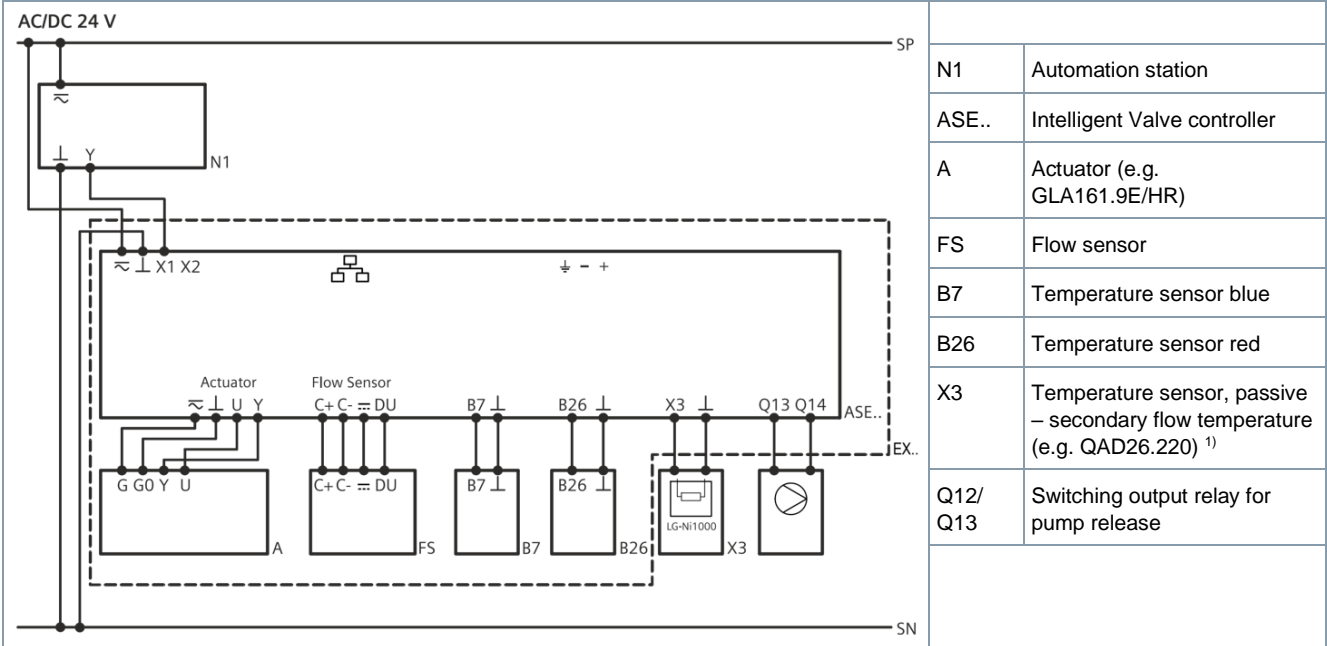

¹⁾ Temperature sensors are not included; they have to be ordered separately.

Control function "Heating circuit outside temperature compensated flow temperature control"

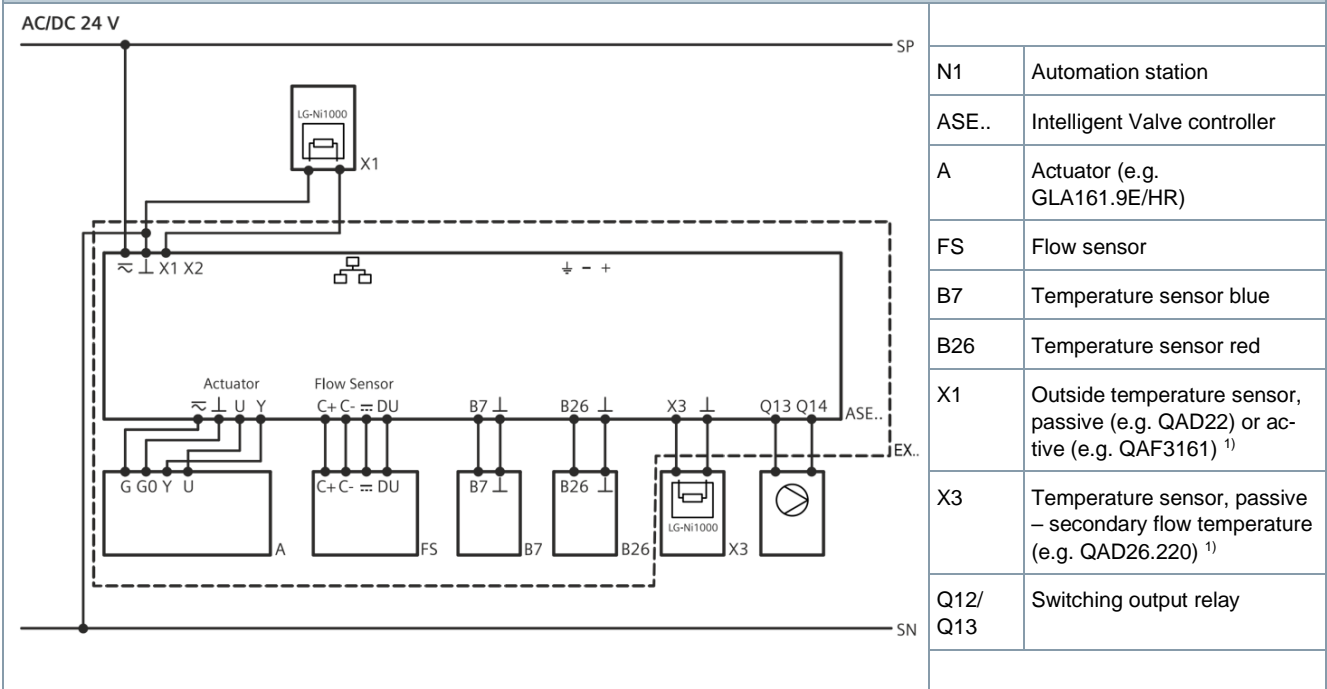

¹⁾ Temperature sensors are not included; they have to be ordered separately.

Intelligent Valve controller, ASE4U10A

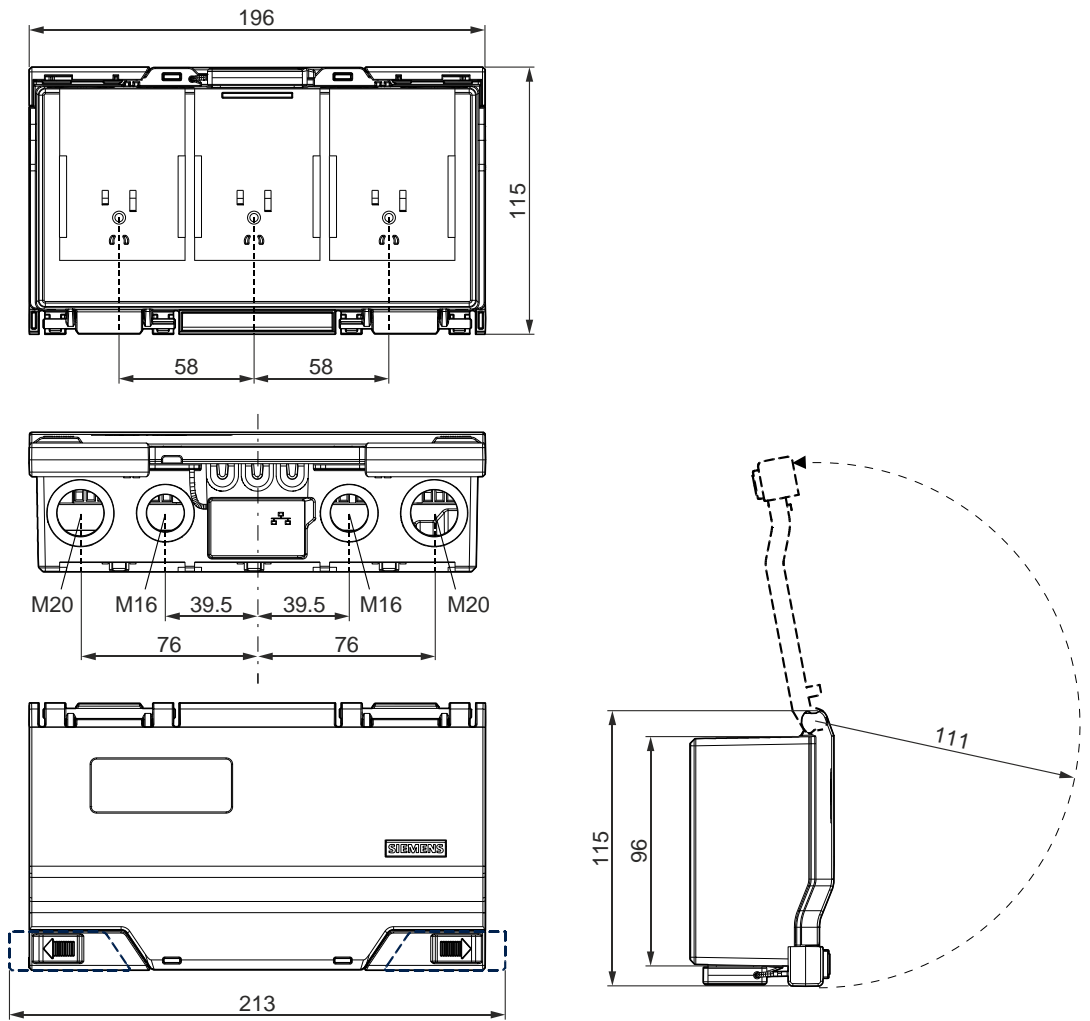

Dimensions in mm

kg
0.5

Threaded, EXG4U10A..

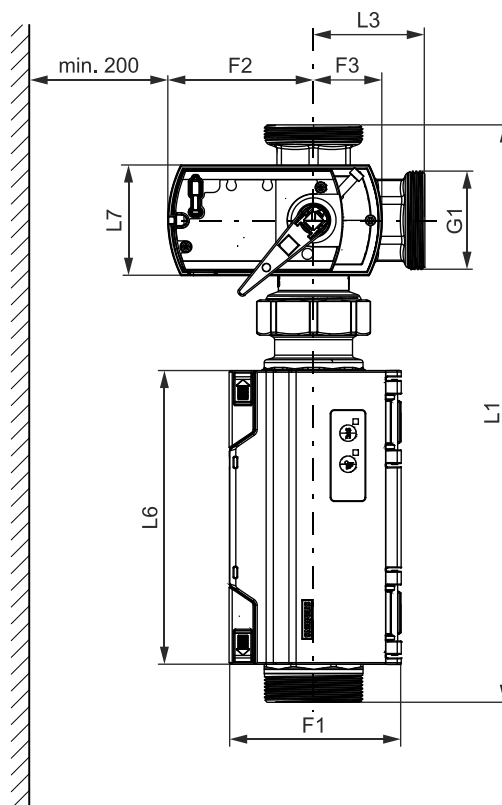
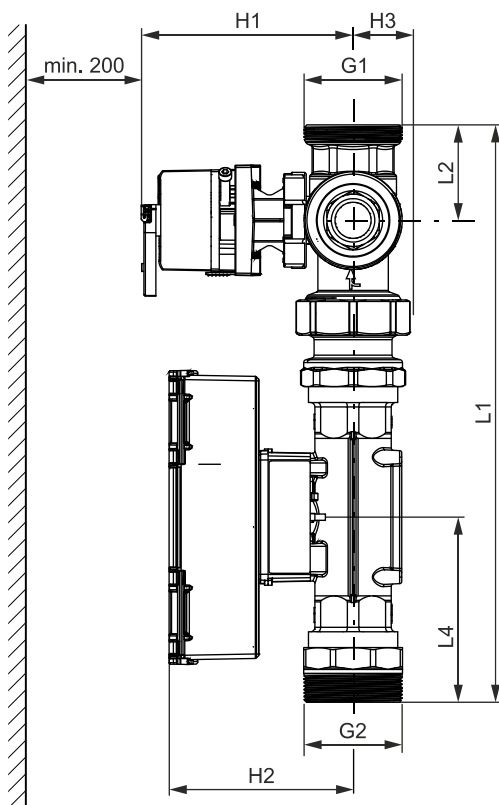
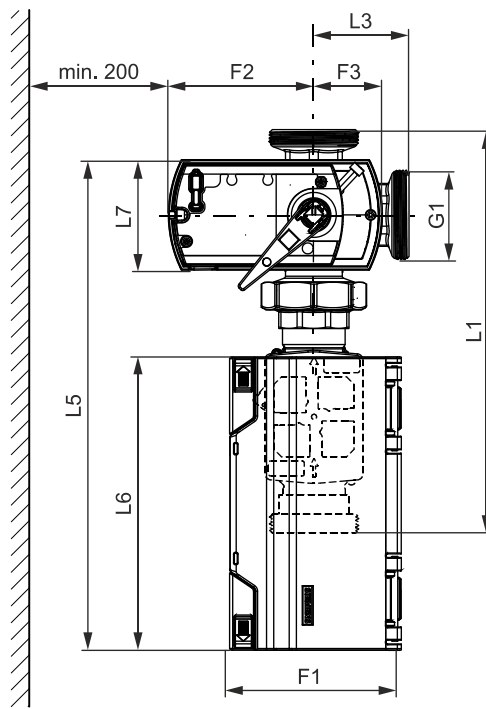
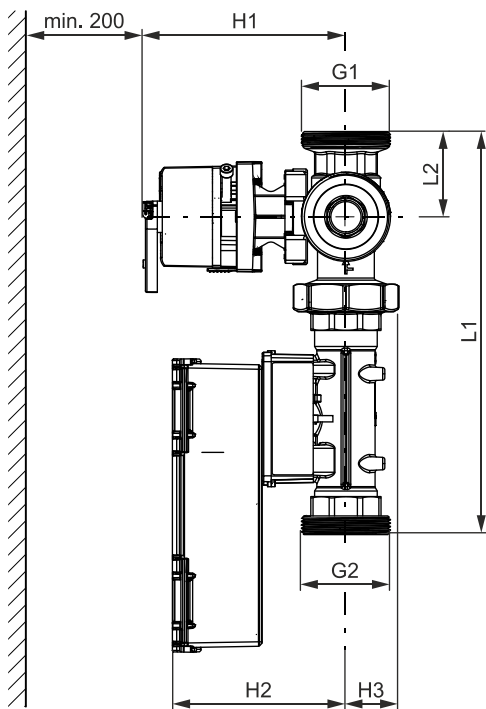

Dimensions in mm

Valve type	F1	F2	F3	G 1	G2	H1	H2	H3	L1	L2	L3	L4	L5	L6	L7	kg
EXG4U10A015	115	98	46	G 1 B	129.5	110.5	110.5	20.5	233	44	64	318	196	74		2.6
EXG4U10A020				G 1¼ B												113
EXG4U10A025				G 1½ B	132	116	27.5	281	49.5	75	349.5	3.6				

Valve type	F1	F2	F3	G 1	G2	H1	H2	H3	L1	L2	L3	L4	L5	L6	L7	kg
EXG4U10A032				G 2 B		136		35.5	269.5	57	63.5	77.5	328			4.0
EXG4U10A040				G 2¼ B		141.5	123	38	385	63.5	74.5	123.5	391			6.4
EXG4U10A050				G 2¾ B		154.5		48	366.5	68.5	82	123	368			7.6

Flanged, EXF4U20A..

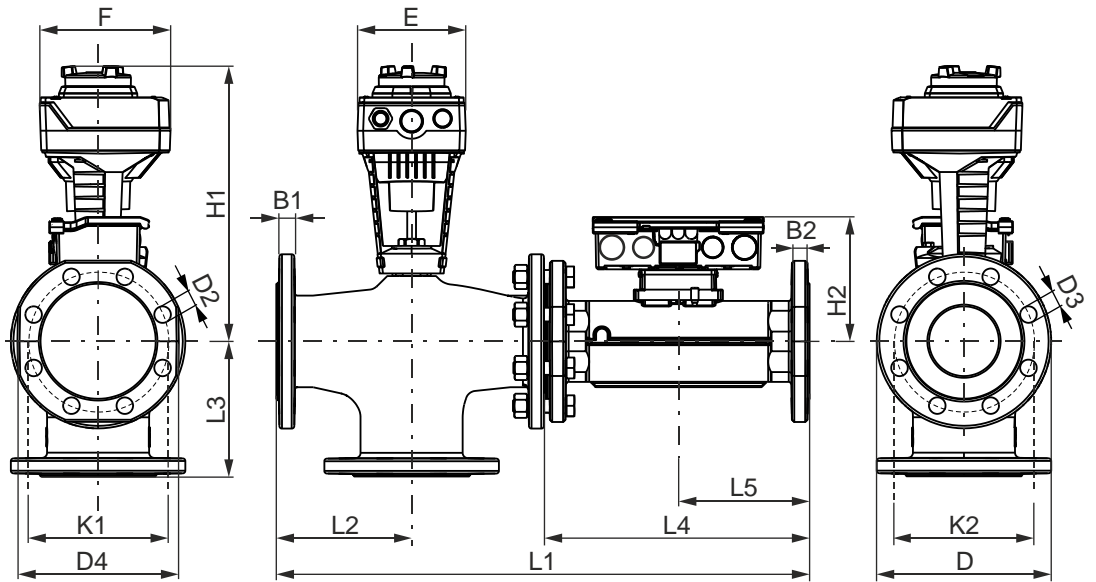

Dimensions in mm

Valve type	B1	B2	D	D2	D3	D4	E	F	H1	H2	K1	K2	L1	L2	L3	L4	L5	kg
EXF4U20A065	17	19	184	18 (4x)	19 (4x)	170				136	145	591	145			300	150	30
EXF4U20A080	19	18	200	19 (8x)	19 (8x)	185	124	150	316	143	160	611	155					37.4
EXF4U20A100	20	23	220			216				375	153	180	711	175				

Temperature sensors EZU..., protective pockets EZT..

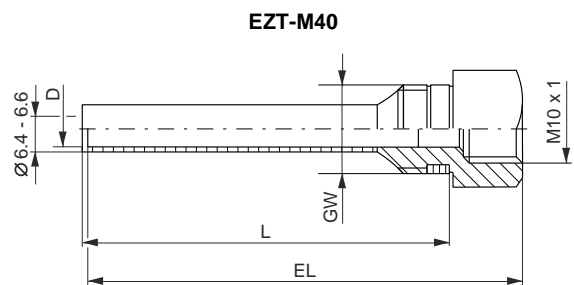
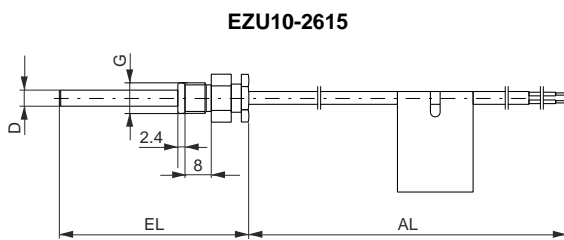

EZU10-10025 / EZU10-10060

EZT-S100

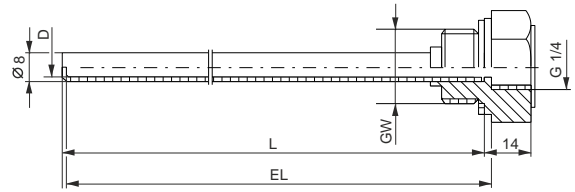
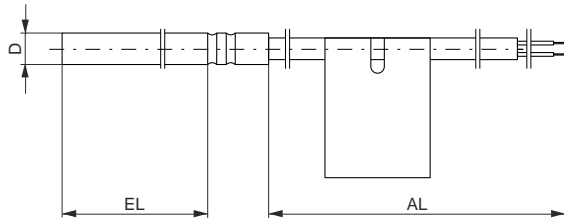

Dimensions in mm

	Temperature sensors						Protective pockets					
	Type	D	EL	G	AL		Type	D	EL	L	GW	SW
	EZU10-2615	5.2	26.5	M10x1	1500		EZT-M40	5.2	50	40	G ¼	17
	EZU10-10025	6	92.5	-	2500		EZT-S100	6.2	100	92.5	G ½	27
	EZU10-10060				6000							

Fittings

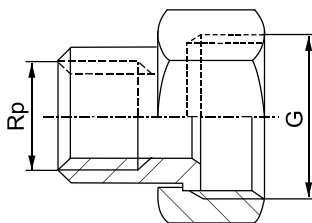

For 3-port valves EXG4U10A.. (3-piece set)		G	Rp	
Type	Valve type	[inch]		
ALG153 / ALG153B	EXG4U10A015	G 1 B	Rp ½	<ul style="list-style-type: none"> • Valve side with cylindrical threading per ISO 228-1 • Pipe side with cylindrical threading per ISO 7-1 • ALG..B fittings up to 100 °C medium temperature
ALG203 / ALG203B	EXG4U10A020	G 1¼ B	Rp ¾	
ALG253 / ALG253B	EXG4U10A025	G 1½ B	Rp 1	
ALG323 / ALG323B	EXG4U10A032	G 2 B	Rp 1¼	
ALG403 / ALG403B	EXG4U10A040	G 2¼ B	Rp 1½	
ALG503 / ALG503B	EXG4U10A050	G 2¾ B	Rp 2	

Revision information

Type	Valid from rev. no.		Type	Valid from rev. no.
EXG4U10A015	..A		EXF4U20A065	..A
EXG4U10A020	..A		EXF4U20A080	..A
EXG4U10A025	..A		EXF4U20A100	..A
EXG4U10A032	..A			
EXG4U10A040	..A			
EXG4U10A050	..A			

Model info	ASN=ASE4U10A; HW=0203
Firmware revision	09.54.14.14; APP=1.23.11783; SVS-300.6.SBC=15.00; ISC=01.00
Application software version	AAS-20:SU=SiUn; APT=HvacFnc34; APTV=2.601

Issued by
Siemens Switzerland Ltd
Smart Infrastructure
Global Headquarters
Theilerstrasse 1a
CH-6300 Zug
+41 58 724 2424
www.siemens.com/buildingtechnologies

© Siemens 2025
Technical specifications and availability subject to change without notice.

Document ID A6V13913365_en--_a
Edition 2025-08-21