

ROTARY MOTORIZED VALVES

EXCHANGE SET ACTUATOR + ADAPTER KIT SERIES 90 3-POINT



Actuator

Adapter kit

ESBE exchange set Series 90 as a replacement for actuator Honeywell VMM20 mounted on a CENTRA mixing valves series ZR/DR/DRG size DN 15-150 or series DRU, DRR size DN 25-32. Valid for installations from year 1990.

SUPPLIED PARTS

Art. No.
12052000 _____ Actuator 95-2
16053900 _____ Adaptor kit 900C

OPERATION

The ESBE series 90 actuator is a compact actuator for operating rotary mixing valves. The actuator is reversible and is provided with limit switches which are actuated by cam discs. By adjusting the cam discs an operating range from 30° to 180° can be obtained. The actuator is provided with a disconnection for manual operation and has an indication on the front showing valve position.

The 3-point signal control actuator is available for 230V, 50 Hz with running time as shown in the table.

OPTIONS

Art. No.
98100690 _____ Separate auxiliary switch

TECHNICAL DATA

Ambient temperature: _____ max. +55°C
 _____ min. - 15°C
 Power supply: _____ 230 ± 10% V AC, 50 Hz
 Power consumption: _____ 5 VA
 Enclosure rating: _____ IP 54
 Protection class: _____ II
 Torque: _____ 15 Nm
 Rating auxiliary switch: _____ 6(3) A 250 V AC
 Weight: _____ 0,8 kg

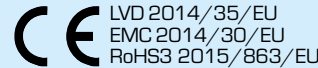

WIRING

Please see the Installation Instruction.

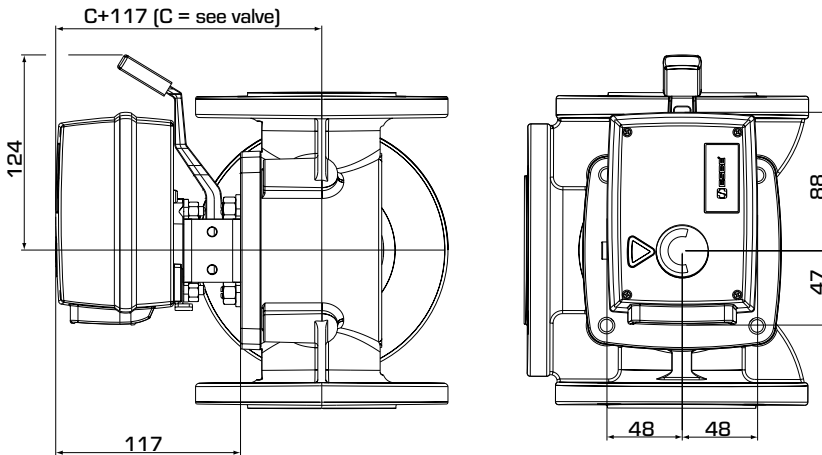

Installation dimensions for Actuator Series 90

SERIES 90, 3-POINT 230 V AC

Art. No.	Reference	Voltage [V AC]	Running time 90° [s]	Torque [Nm]	Control signal *	Remark
12052000	95-2	230	120	15	3-point SPDT	Separate auxiliary switch as option

* 3-point SPDT = Single Pole Double Throw