

Data sheet

Manual presetting valve MSV-F2, PN 16/25, DN 15 - 400

Description



MSV-F2 valves are manual presetting valves with flanged connections. They are used for balancing the flow in heating and cooling installations.

The valves have a position indicator and stroke limiter as standard. The hand wheel of the valve is integrated with the stroke limiter.

The setting can be locked. Valve characteristics are set up in measuring device PFM 1000/PFM 100. Valves are free of asbestos.

Shut-off function.

Main data:

- DN 15-400
- PN 16:
 - Flow temperature: -10 °C ... 130 °C
- PN 25:
 - Flow temperature: -10 °C ... 150 °C
- Valves can be mounted in the supply or return pipe.

Application

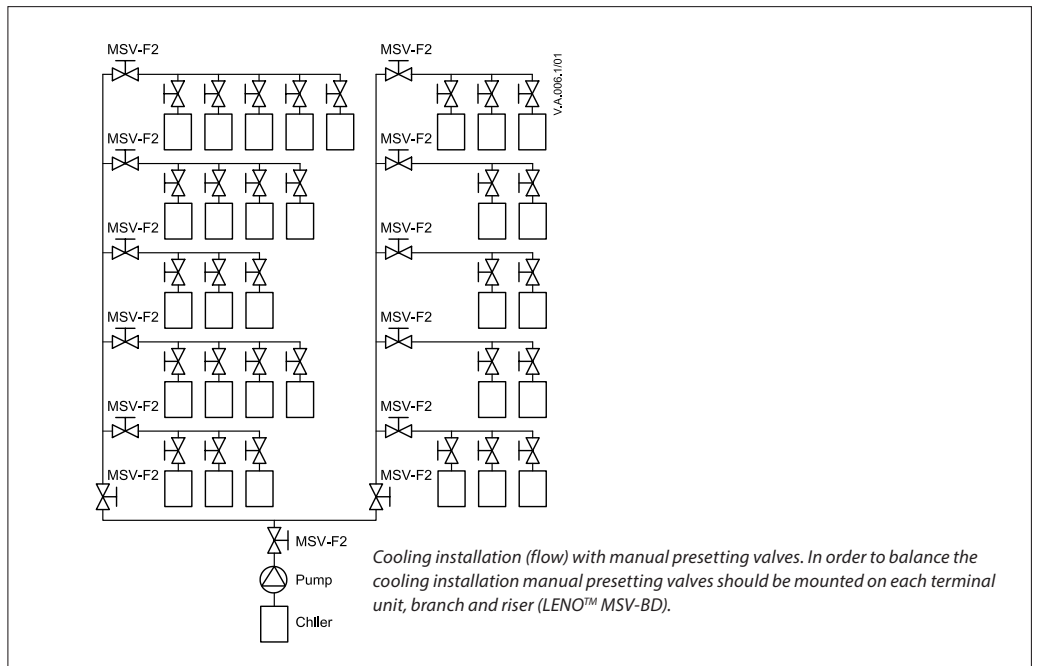

Ordering

MSV-F2 valves - PN 16

Picture	DN ¹⁾ (mm)	k _{vs} (m ³ /h)	T _{max.} (°C)	PN (bar)	Code No. (with needle test plugs)
	15	3.1	130	16	003Z1085
	20	6.3			003Z1086
	25	9.0			003Z1087
	32	15.5			003Z1088
	40	32.3			003Z1089
	50	53.8			003Z1061
	65	93.4			003Z1062
	80	122.3			003Z1063
	100	200.0			003Z1064
	125	304.4			003Z1065
	150	400.8			003Z1066
	200	872			003Z1140
	250	1,238			003Z1141
	300	1,662			003Z1142
	350	2,359			003Z1143
	400	3,516			003Z1144

MSV-F2 valves - PN 25

Picture	DN ¹⁾ (mm)	k _{vs} (m ³ /h)	T _{max.} (°C)	PN (bar)	Code No. (with needle test plugs)
	15		150	25	003Z1092
	20	6.3			003Z1093
	25	9.0			003Z1094
	32	15.5			003Z1095
	40	32.3			003Z1096
	50	53.8			003Z1070
	65	93.4			003Z1071
	80	122.3			003Z1072
	100	200.0			003Z1073
	125	304.4			003Z1074
	150	400.8			003Z1075
	200	685.6			003Z1076
	250	952.3			003Z1077
	300	1,380.2			003Z1078
	350	2,046.1			003Z1097
	400	2,584.6			003Z1098

¹⁾ Flange valves dimension DN 15-40, 350 and 400 available on request.

Accessories

Type	Code No.
Rectus test plugs, 2 pcs.	003Z0108
Standard test plugs with O-ring, 2 pcs.	003Z0104
Extension piece for test plugs 45 mm, 2 pcs.	003Z0103
Extended test plugs mounted under pressure, 2 pcs.	003Z3946
Flow measuring instrument PFM5001 (10 bar)	003L8343
Flow measuring instrument PFM1000 (10 bar)	003Z8260
Flow measuring instrument PFM1000 (20 bar)	003Z8261

	Type	Code No.
Hand-wheel	DN 15-50	003Z0179
	DN 65-150	003Z0180
	DN 200	003Z0181
	DN 250-300	003Z0182
	DN 350-400	003Z0183

Technical data

MSV-F2 valves - PN 16

Nominal diameter	DN	15	20	25	32	40	50	65	80	100	125	150	200	250	300	350	400
k_{vs}	m ³ /h	3.1	6.3	9.0	15.5	32.3	53.8	93.4	122.3	200.0	304.4	400.8	872	1,238	1,662	2,359	3,516
Nominal pressure	bar	16															
Max. pressure drop		1.5															
Leakage rate	Grade A; According to ISO5208, Table 5 (No visible leakage)																
Flow medium	Water and water mixtures with secondary coolants (like glycols ¹⁾) for closed heating and cooling systems																
Max. flow temperature	°C	130															
Connections	Flanges according to EN 1092-2																
Weight	kg	2.3	2.9	3.8	5.6	7.2	9.4	17	21	32	44	56.5	98	153	247	374	550
Material																	
Body	Cast iron EN-GJL 250 (GG 25)																
Seat sealing	EPDM																
Cone	CW602N									Stainless steel	Stainless steel/ CW602N	Casted stainless steel					

¹⁾ Please verify compability between materials and secondary coolants with supplier.

MSV-F2 valves - PN 25W

Nominal diameter	DN	15	20	25	32	40	50	65	80	100	125	150	200	250	300	350	400
k_{vs}	m ³ /h	3.1	6.3	9.0	15.5	32.3	53.8	93.4	122.3	200.0	304.4	400.8	685.6	952.3	1380.2	2046.1	2584.6
Nominal pressure	bar	25															
Max. pressure drop		2.0															
Leakage rate	Grade A; According to ISO5208, Table 5 (No visible leakage)																
Flow medium	Water and water mixtures with secondary coolants (like glycols ¹⁾) for closed heating and cooling systems																
Max. flow temperature	°C	150															
Connections	Flanges according to EN 1092-2																
Weight	kg	2.3	3.0	3.8	5.8	7.2	9.4	17	21	33	44	56.5	228	345	488	748	900
Material, we ha																	
Body	Ductile iron EN-GJS 400-15 (GGG-40)																
Seat sealing	EPDM																
Cone	CW602N									Stainless steel	Stainless steel CW602N	Casted stainless steel					

¹⁾ Please verify compability between materials and secondary coolants with supplier.qw

Pressure-temperature classification (flanges according to EN 1092-2)

Material	PN		Temperature			
			-10 °C	120 °C	130 °C	150 °C
EN-GJL 250 (MSV-F2 DN 15-150)	16	bar	16	16	15.5	-
EN-GJL 250 (MSV-F2 DN 200-400)	16		16	16	15.5	-
EN-GJS 400-15 (MSV-F2 DN 15-150)	25		25	25	-	24.3
EN-GJS 400-15 (MSV-F2 DN 200-400)	25		25	25	-	24.3

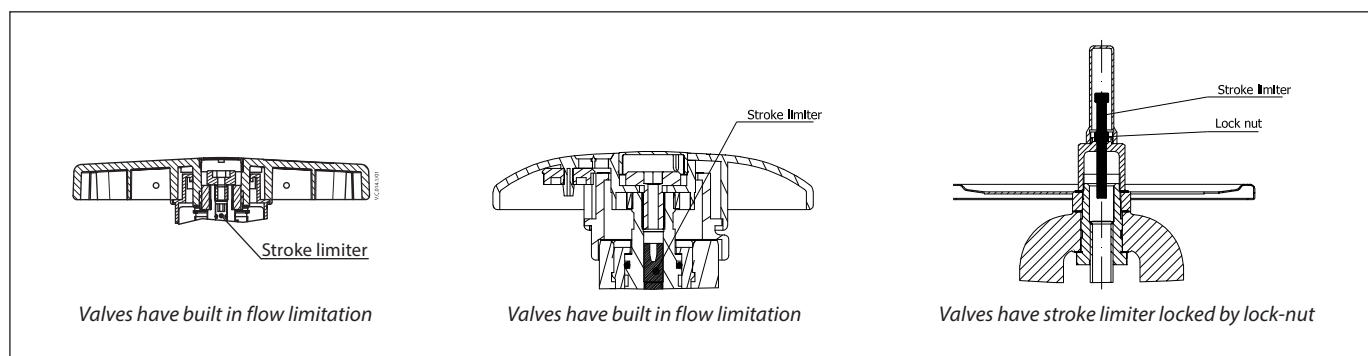

Design

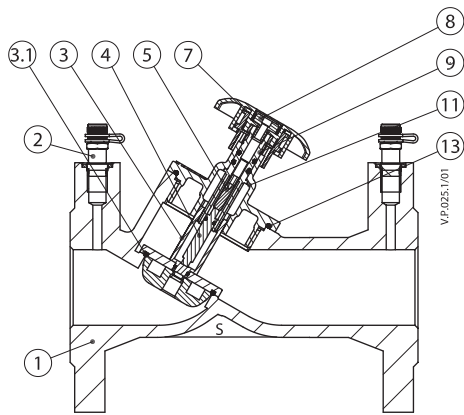

MSV-F2 DN 15-40

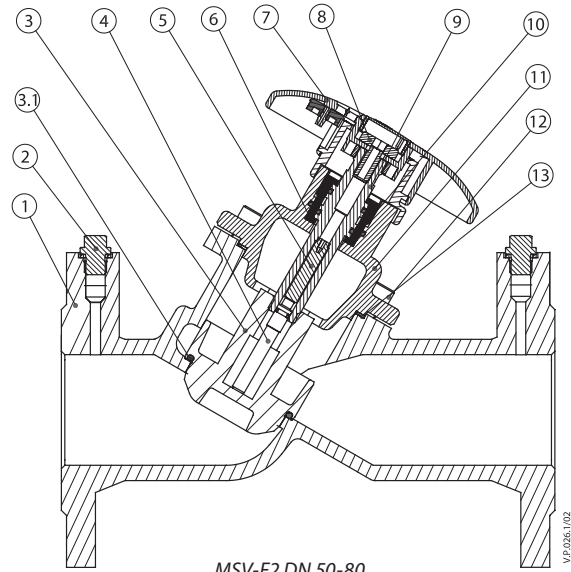

MSV-F2 DN 50-80

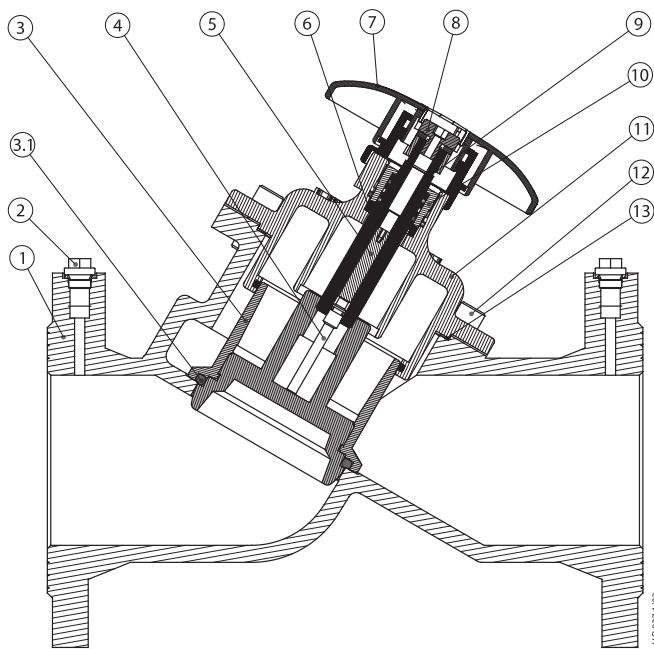

MSV-F2 DN 100-150

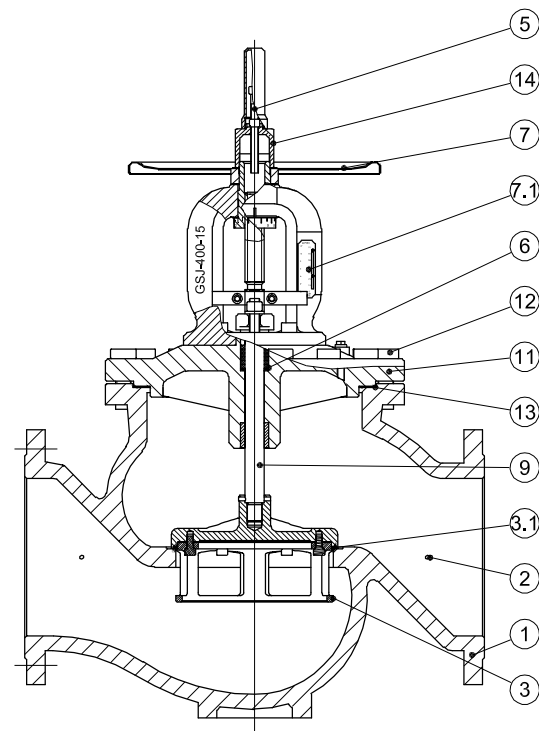

MSV-F2 DN 200-400 (PN 25)

- 1 Body EN-GJL250
- 2 Plug
- 3 Valve cone
- 3,1 Seat soft sealing
- 4 Rod
- 5 Stroke limiter/Allen screw
- 6 Gasket
- 7 Handwheel with digital display
 - DN 15-150 plastic
 - DN 200-400 metal

- 7,1 Display
- 8 Fixed screw
- 9 Spindle
- 10 Stuffing box
- 11 Bonnet
- 12 Allen screw /Hexagon screw
- 13 Flat gasket
- 14 Hood with stroke

Design (continued)

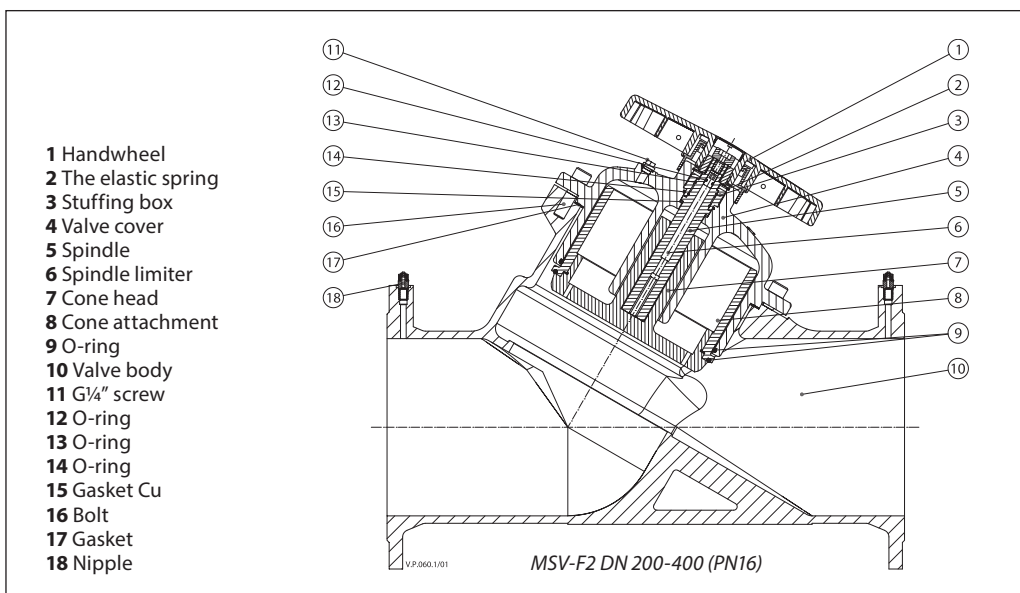

- 1 Handwheel
- 2 The elastic spring
- 3 Stuffing box
- 4 Valve cover
- 5 Spindle
- 6 Spindle limiter
- 7 Cone head
- 8 Cone attachment
- 9 O-ring
- 10 Valve body
- 11 G1/4" screw
- 12 O-ring
- 13 O-ring
- 14 O-ring
- 15 Gasket Cu
- 16 Bolt
- 17 Gasket
- 18 Nipple

Setting

Ethylenglycol correction factor

Formula: $C_2H_6O_2$
 Density at 20 °C: $\rho_{water} = 1 \text{ kg/dm}^3$
 $\rho_{glycol} = 1.338 \text{ kg/dm}^3$

$$Q_{corr.} = \frac{Q_{water}}{\sqrt{\text{Share of water} \times \rho_{water} + \text{Share of glycol} \times \rho_{glycol}}}$$

Ethylenglycol part xg (%)	0	10	20	30	40	50	60	70	80	90	100
Correction factor	1.0	0.983	0.968	0.953	0.939	0.925	0.912	0.899	0.887	0.876	0.864

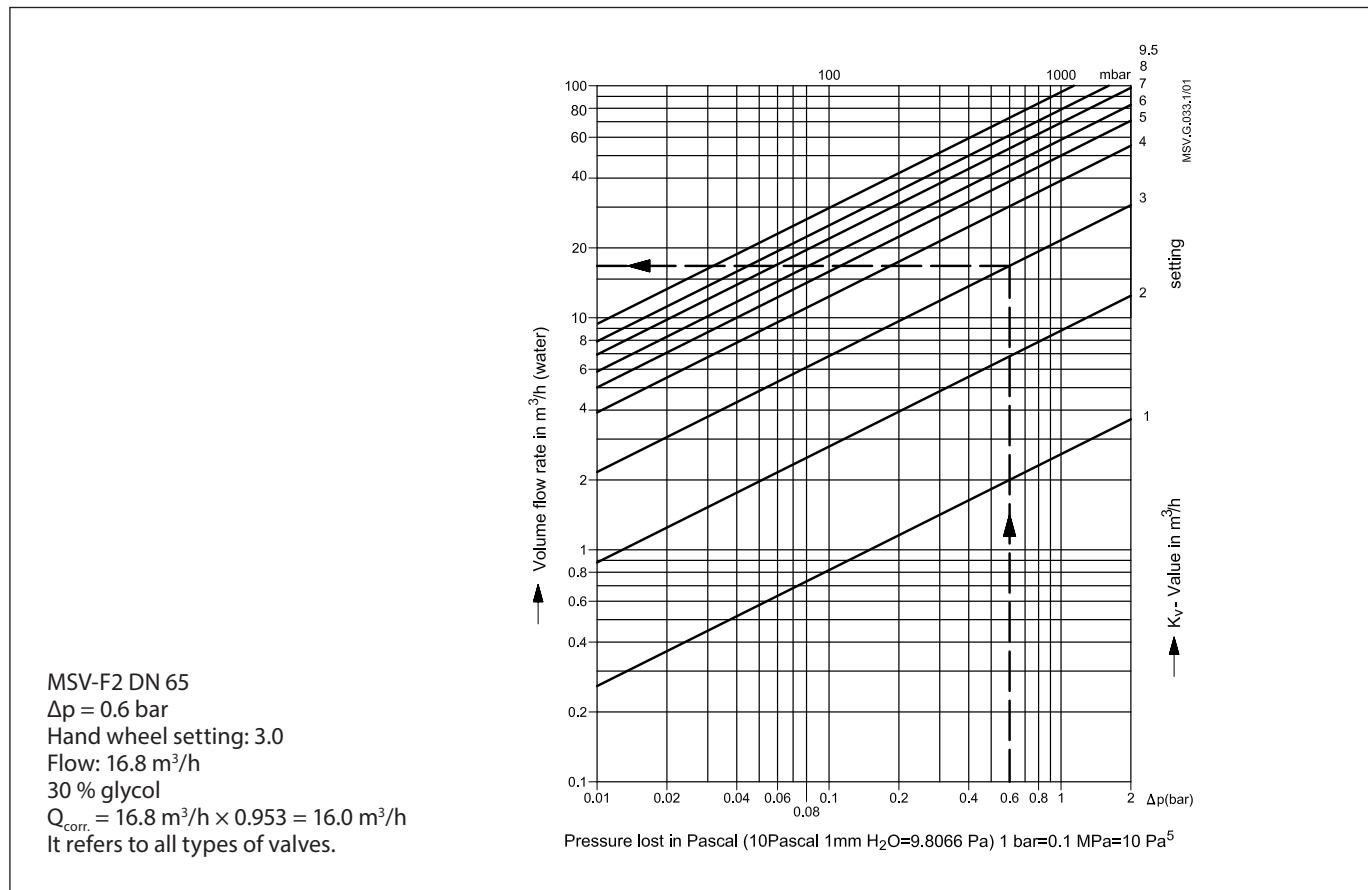

Installation

Always install the valve with the arrow on the body in the same direction as the flow. In order to avoid turbulence, which will affect the measuring accuracy, it is recommended to have a straight length of pipe up and down stream from the valve as shown (D - diameter of pipe).

The influence of turbulence, if our recommendations are not adhered to, can influence the flow up to 20 %.

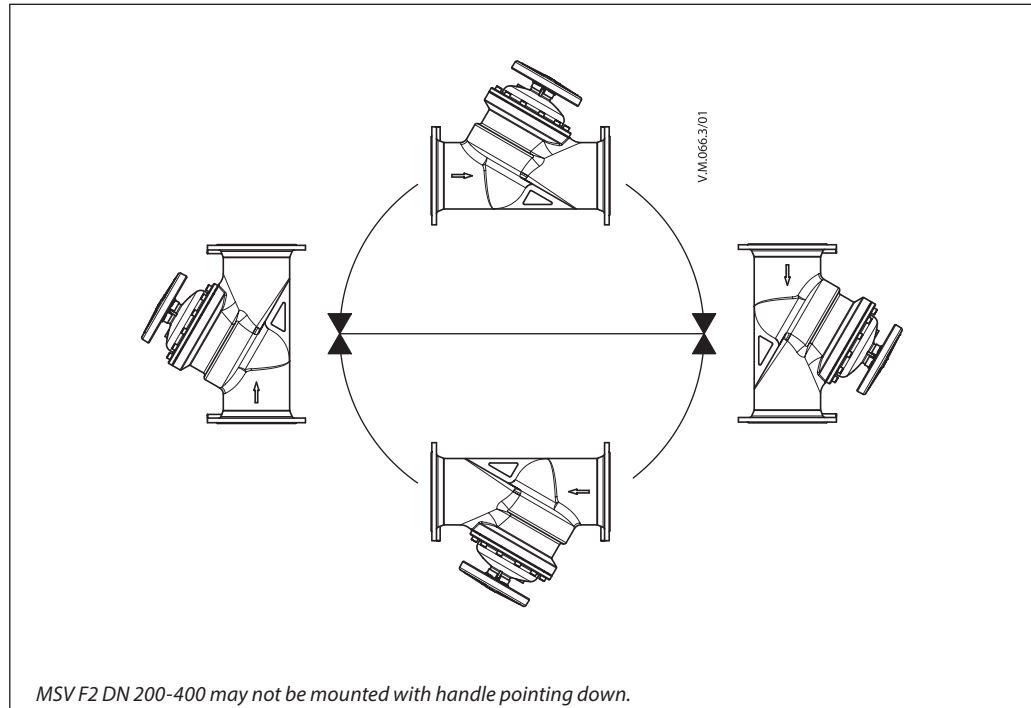
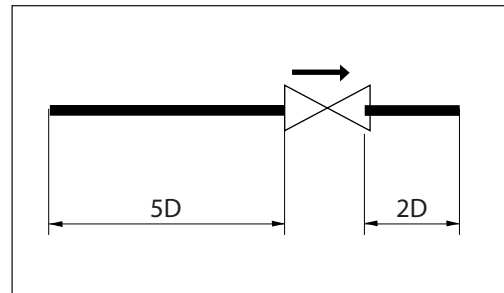

Sizing

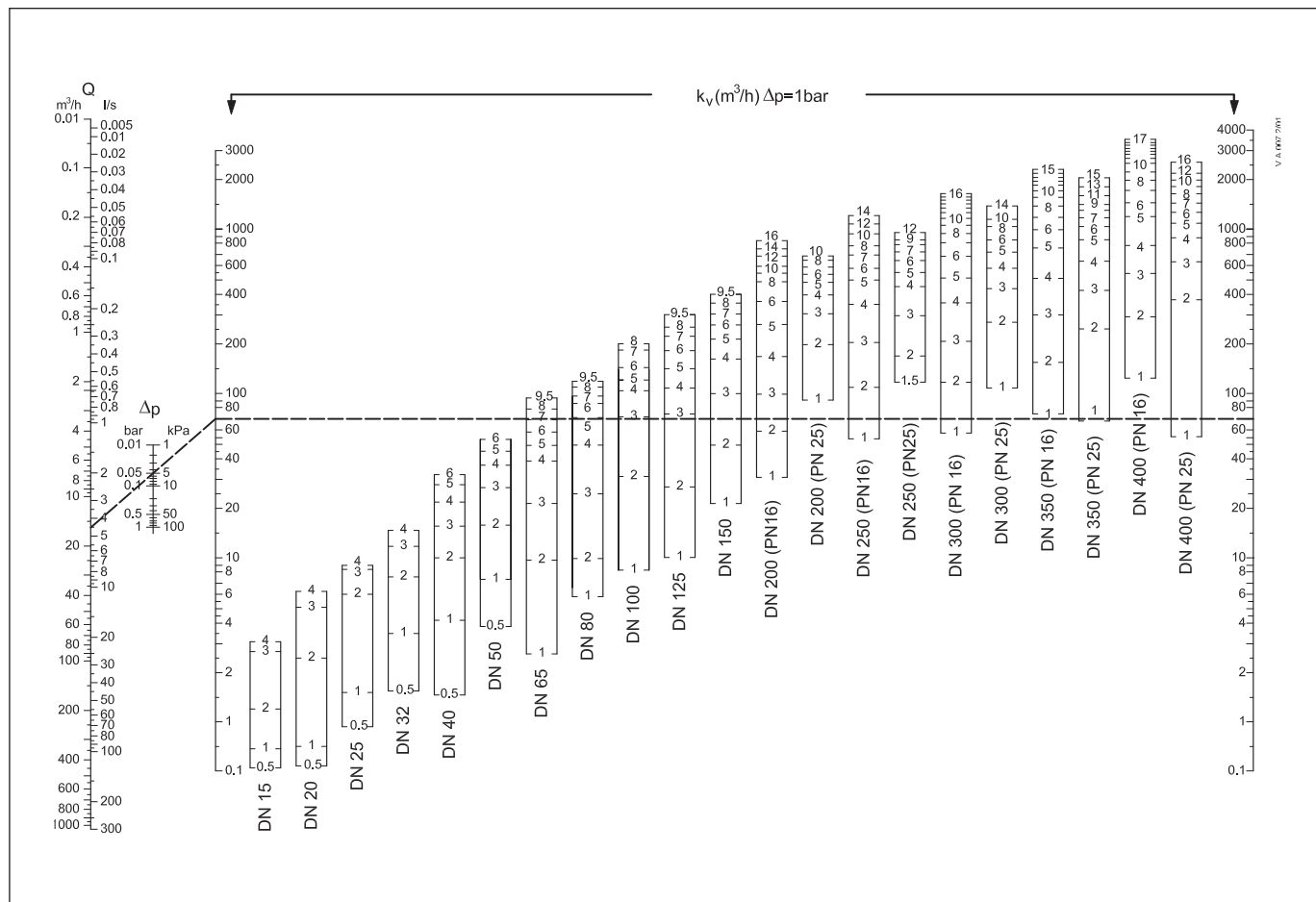

Example:
 MSV-F2 DN 65
 Q = 16 m³/h
 Δp = 5 kPa

Calculation for the valve setting:
 Draw a straight line from the desired flow
 (16 m³/h) through the differential pressure
 (5 kPa) to k_v scale.

From the k_v value draw a horizontal line. Where
 it intersects the given valve (DN65) you can find
 the valve setting.

Result:
 presetting 7.0

Flow diagrams

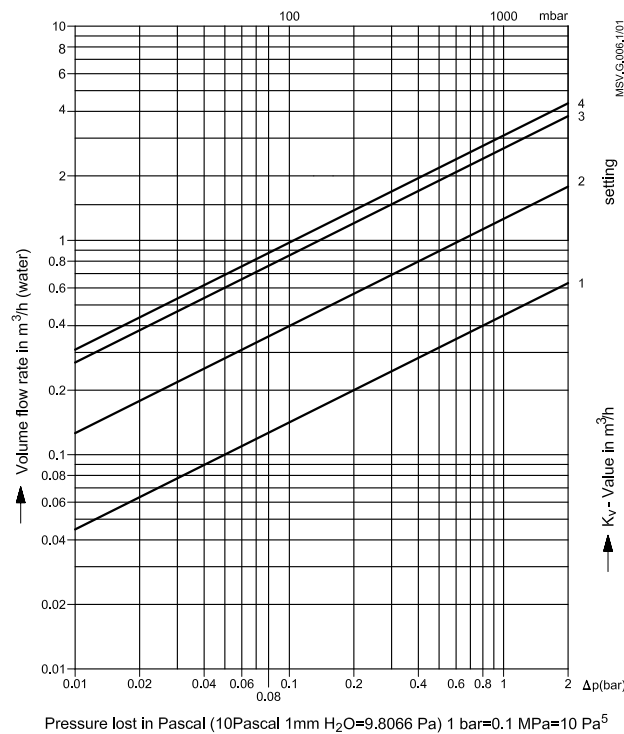

DN 15 / PN 16 / PN 25

Setting	k _v -value
1	0.45
2	1.26
3	2.73
4	3.09

Max. permissible differential pressure in throttling function 1.5/2.0 bar.
 Max. permissible flow speed: ≤ 4 m/s
 Condition:

- The flow must be free of cavitation.

Flow characteristic

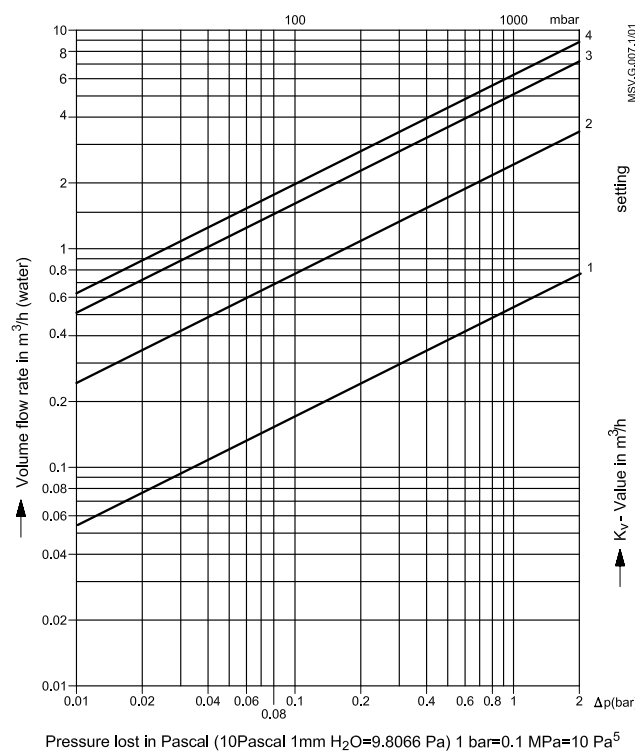
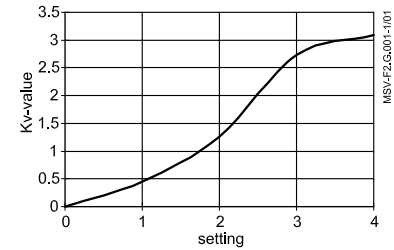

DN 20 / PN 16 / PN 25

Setting	k _v -value
1	0.54
2	2.48
3	5.11
4	6.26

Max. permissible differential pressure in throttling function 1.5/2.0 bar.
 Max. permissible flow speed: ≤ 4 m/s
 Condition:

- The flow must be free of cavitation.

Flow characteristic

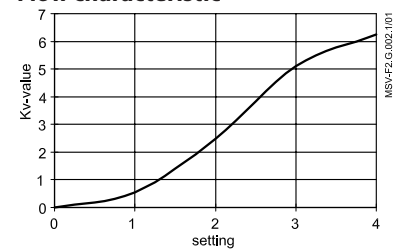

Flow diagrams (continued)

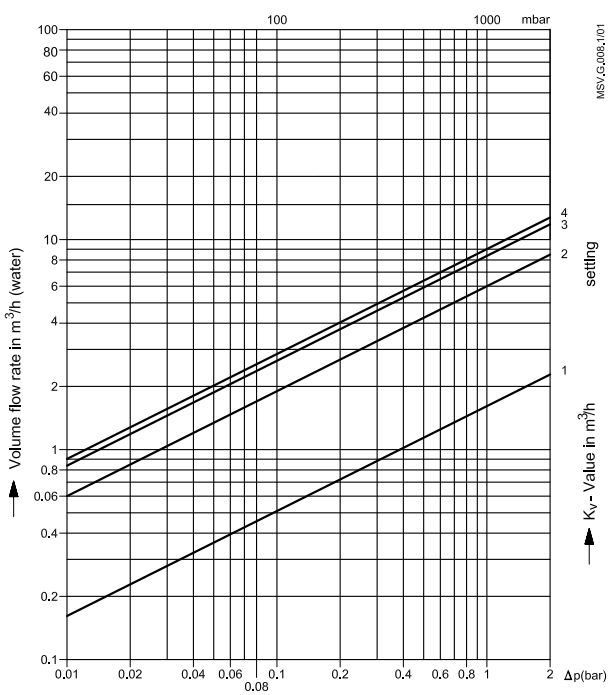

Pressure lost in Pascal (10Pascal 1mm H₂O=9.8066 Pa) 1 bar=0.1 MPa=10 Pa⁵

DN 25 / PN 16 / PN 25

Setting	k _v -value
1	1.61
2	6.0
3	8.38
4	9.01

Max. permissible differential pressure in throttling function 1.5/2.0 bar.
 Max. permissible flow speed: ≤ 4 m/s
 Condition:

- The flow must be free of cavitation.

Flow characteristic

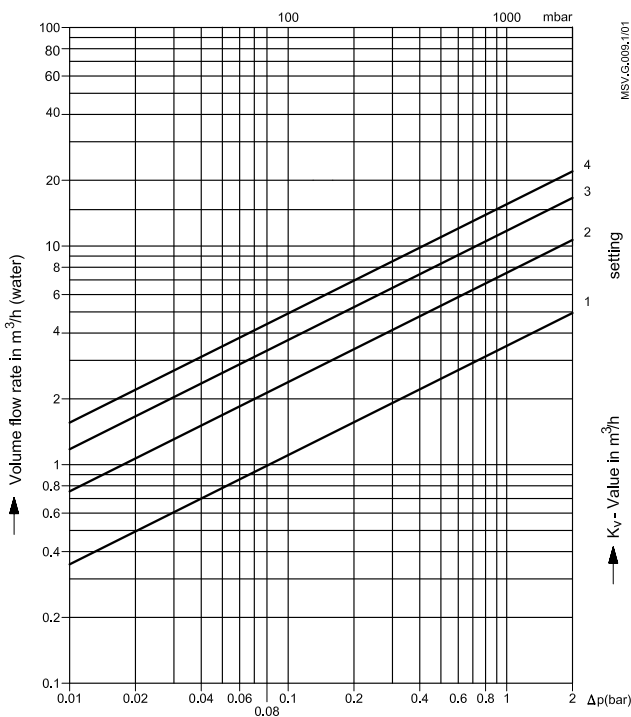
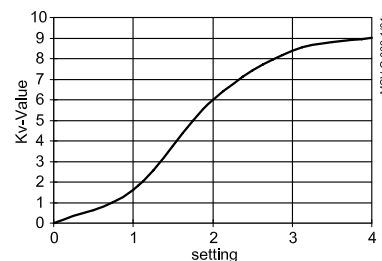

Pressure lost in Pascal (10Pascal 1mm H₂O=9.8066 Pa) 1 bar=0.1 MPa=10 Pa⁵

DN 32 / PN 16 / PN 25

Setting	k _v -value
1	3.53
2	7.56
3	12.32
4	15.54

Max. permissible differential pressure in throttling function 1.5/2.0 bar.
 Max. permissible flow speed: ≤ 4 m/s
 Condition:

- The flow must be free of cavitation.

Flow characteristic

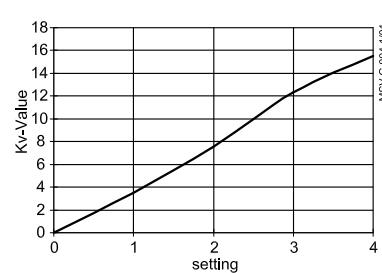

Flow diagrams (continued)

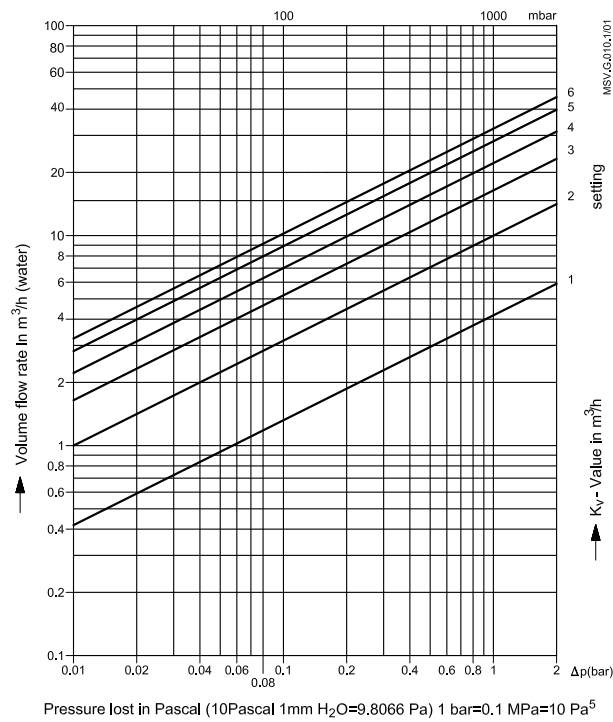

DN 40 / PN 16 / PN 25

Setting	k _v -value
1	4.19
2	9.98
3	16.42
4	22.13
5	28.14
6	32.31

Max. permissible differential pressure in throttling function 1.5/2.0 bar.
 Max. permissible flow speed: ≤ 4 m/s
 Condition:

- The flow must be free of cavitation.

Flow characteristic

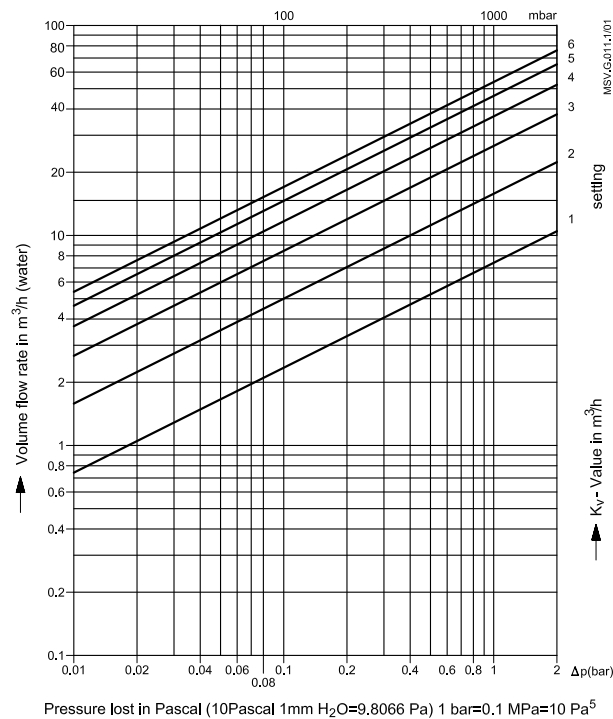
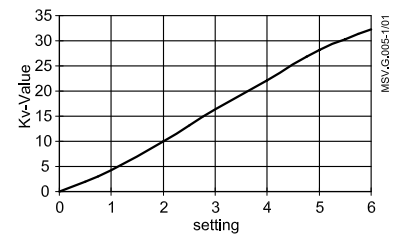

DN 50 / PN 16 / PN 25

Setting	k _v -value
1	7.4
2	15.8
3	26.7
4	36.9
5	46.2
6	53.8

Max. permissible differential pressure in throttling function 1.5/2.0 bar.
 Max. permissible flow speed: ≤ 4 m/s
 Condition:

- The flow must be free of cavitation.

Flow characteristic

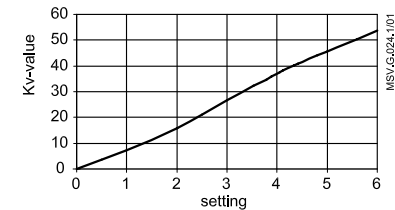

Flow diagrams (continued)

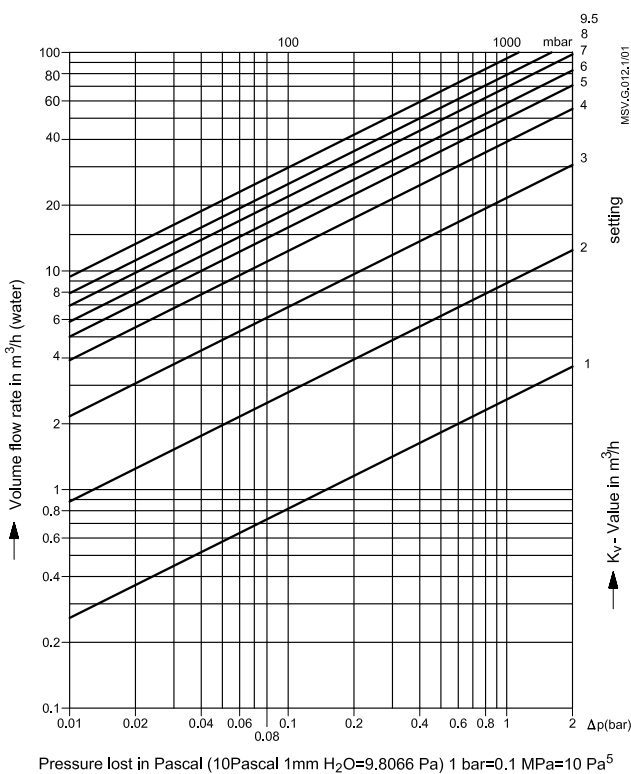

DN 65 / PN 16 / PN 25

Setting	k _v -value
1	2.6
2	8.8
3	21.6
4	39.0
5	49.8
6	58.5
7	69.3
8	79.0
9	87.8
9.5	93.4

Max. permissible differential pressure in throttling function 1.5/2.0 bar.
 Max. permissible flow speed: ≤ 4 m/s
 Condition:

- The flow must be free of cavitation.

Flow characteristic

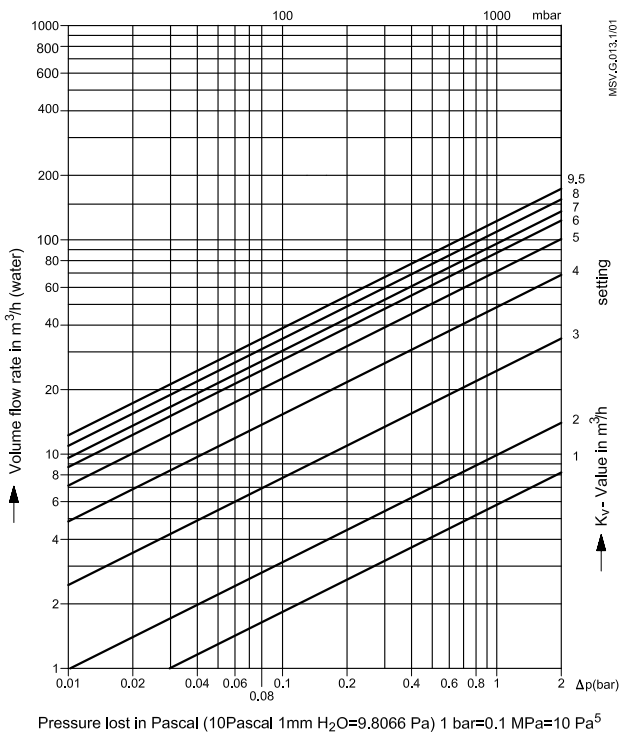
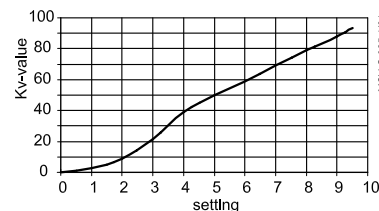

DN 80 / PN 16 / PN 25

Setting	k _v -value
1	5.8
2	9.9
3	24.5
4	48.5
5	71.3
6	87.0
7	96.4
8	109.3
9.5	122.3

Max. permissible differential pressure in throttling function 1.5/2.0 bar.
 Max. permissible flow speed: ≤ 4 m/s
 Condition:

- The flow must be free of cavitation.

Flow characteristic

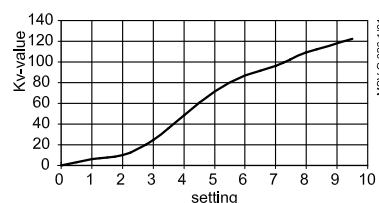

Flow diagrams (continued)

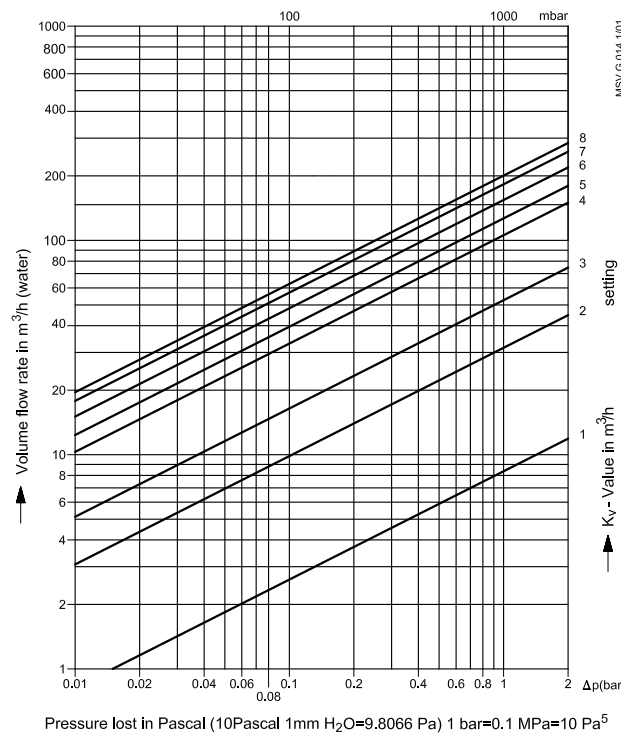

DN 100 / PN 16 / PN 25

Setting	k_v -value
1	8.3
2	32.4
3	72.9
4	107.2
5	128.2
6	152.8
7	180.0
8	200.0

Max. permissible differential pressure in throttling function 1.5/2.0 bar.

Max. permissible flow speed: ≤ 4 m/s

Condition:

- The flow must be free of cavitation.

Flow characteristic

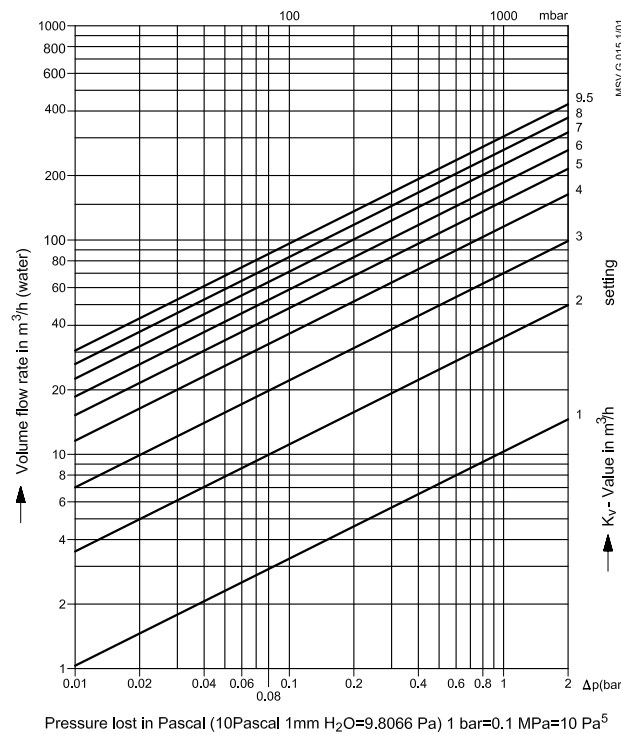
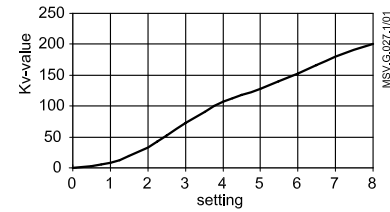

DN 125 / PN 16 / PN 25

Setting	k_v -value
1	10.3
2	35.4
3	73.0
4	114.9
5	150.5
6	185.2
7	225.1
8	261.1
9	294.2
9.5	304.4

Max. permissible differential pressure in throttling function 1.5/2.0 bar.

Max. permissible flow speed: ≤ 4 m/s

Condition:

- The flow must be free of cavitation.

Flow characteristic

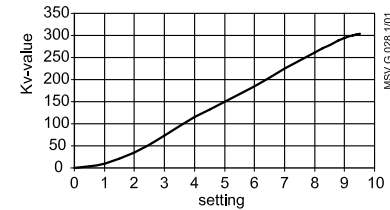

Flow diagrams (continued)

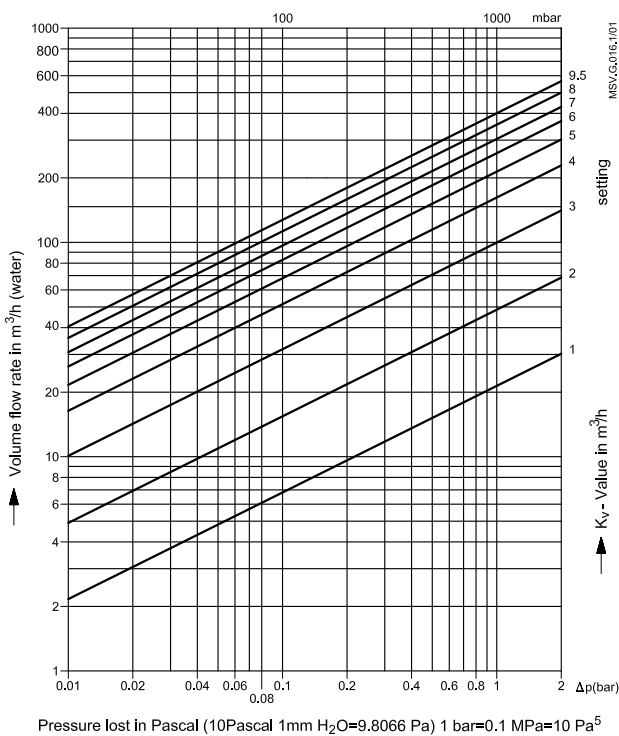

DN 150 / PN 16 / PN 25

Setting	k_v -value
1	21.4
2	48.5
3	99.8
4	162.0
5	214.0
6	260.9
7	304.1
8	354.6
9.5	400.8

Max. permissible differential pressure in throttling function 1.5/2.0 bar.
 Max. permissible flow speed: ≤ 4 m/s
 Condition:
 • The flow must be free of cavitation.

Flow characteristic

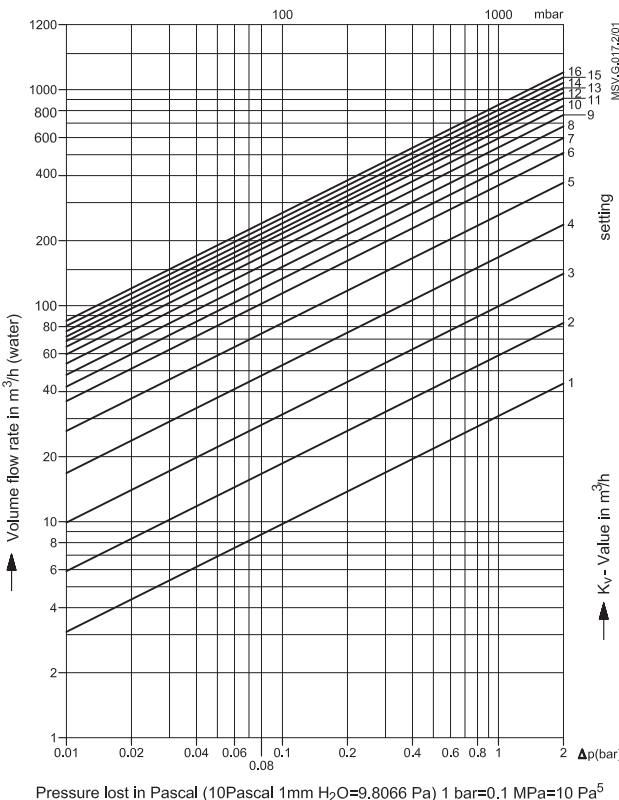
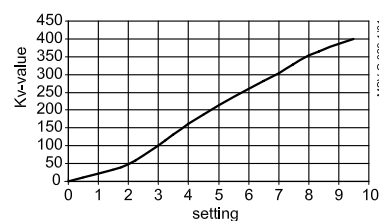

DN 200 / PN 16

Setting	k_v -value
1	30.8
2	58.7
3	100
4	170
5	262
6	361
7	423
8	481
9	542
10	597
11	647
12	684
13	722
14	763
15	807
16	850
Max: 16.7	872

Max. permissible differential pressure in throttling function 1.5 bar.
 Max. permissible flow speed: ≤ 4 m/s
 Condition:
 • The flow must be free of cavitation.

Flow characteristic

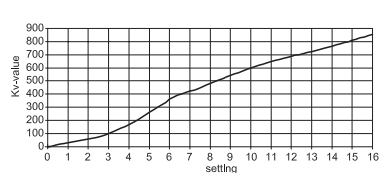

Flow diagrams (continued)

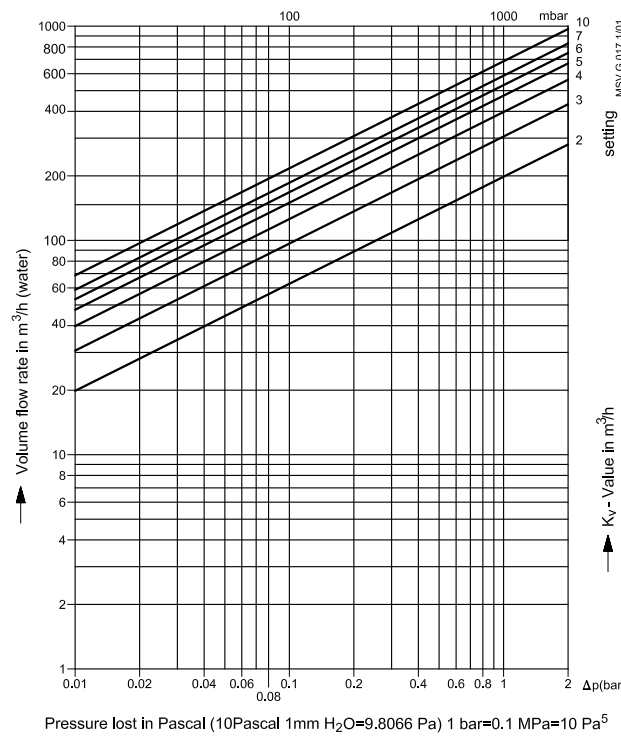

DN 200 / PN 25

Setting	k _v -value
2	198.2
3	305.3
4	397.5
5	474.0
6	530.4
7	586.8
8	645.9
10	685.6

Max. permissible differential pressure in throttling function 2.0 bar.

Max. permissible flow speed: ≤ 4 m/s

Condition:

- The flow must be free of cavitation.

Flow characteristic

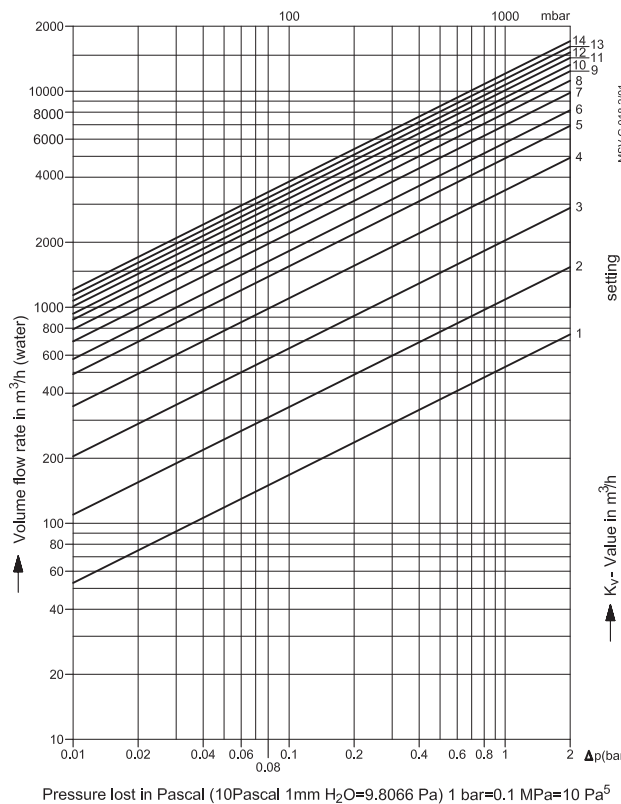
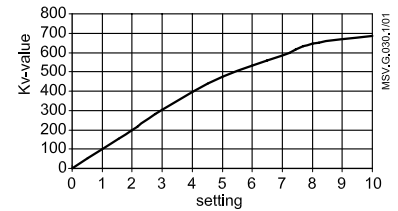

DN 250 / PN 16

Setting	k _v -value
1	53.6
2	109
3	207
4	349
5	490
6	580
7	693
8	791
9	877
10	942
11	1012
12	1076
13	1140
14	1211
Max: 14.4	1238

Max. permissible differential pressure in throttling function 1.5 bar.

Max. permissible flow speed: ≤ 4 m/s

Condition:

- The flow must be free of cavitation.

Flow characteristic

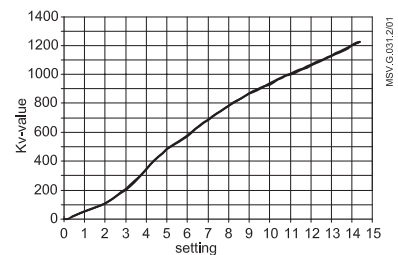

Flow diagrams (continued)

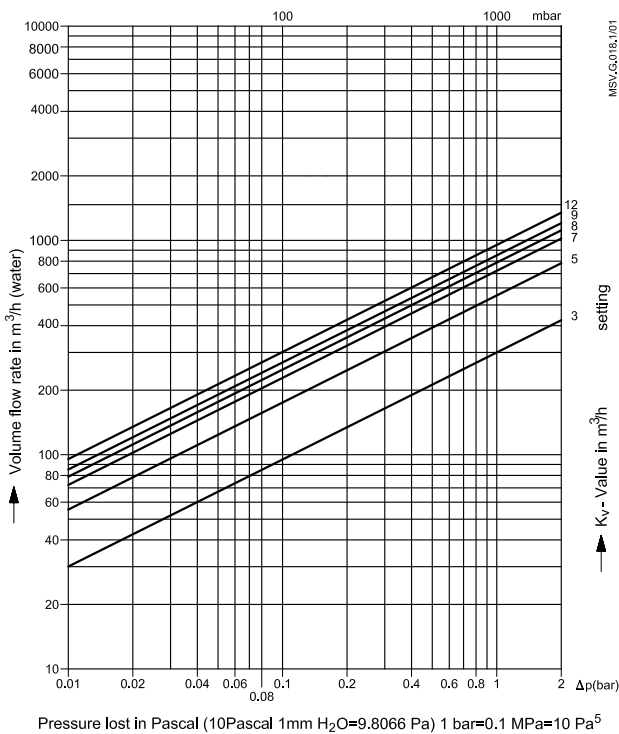

DN 250 / PN 25

Setting	k _v -value
3	299.4
5	553.1
7	721.2
8	788.1
9	851.1
10	926.1
12	952.3

Max. permissible differential pressure in throttling function 2.0 bar.

Max. permissible flow speed: ≤ 4 m/s

Condition:

- The flow must be free of cavitation.

Flow characteristic

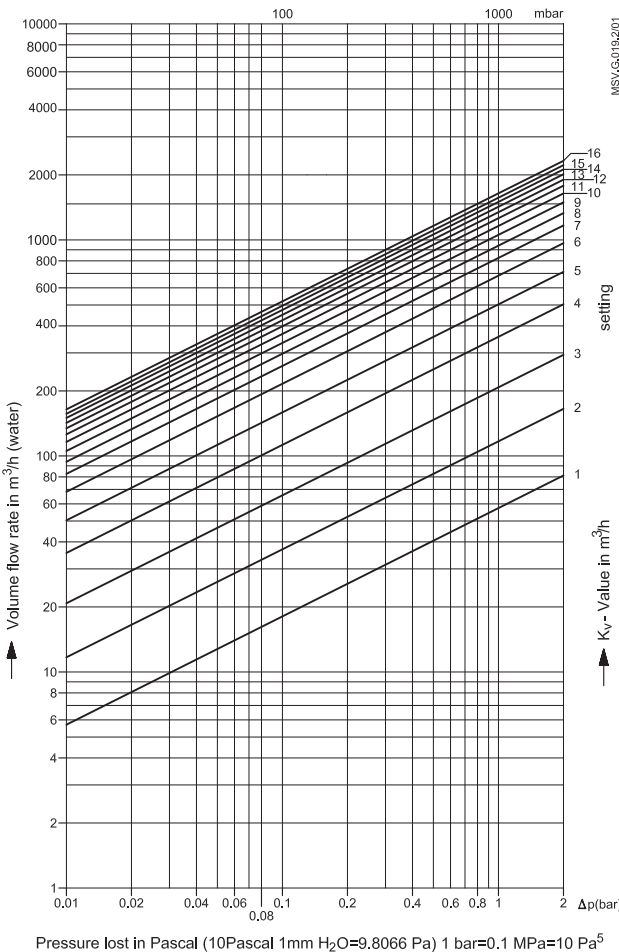
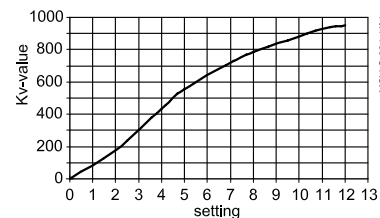

DN 300 / PN 16

Setting	k _v -value
1	57.4
2	117
3	208
4	356
5	503
6	683
7	826
8	940
9	1055
10	1161
11	1260
12	1343
13	1423
14	1500
15	1568
16	1643
Max: 16.4	1662

Max. permissible differential pressure in throttling function 1.5 bar.

Max. permissible flow speed: ≤ 4 m/s

Condition:

- The flow must be free of cavitation.

Flow characteristic

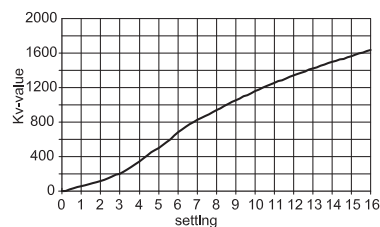

Flow diagrams (continued)

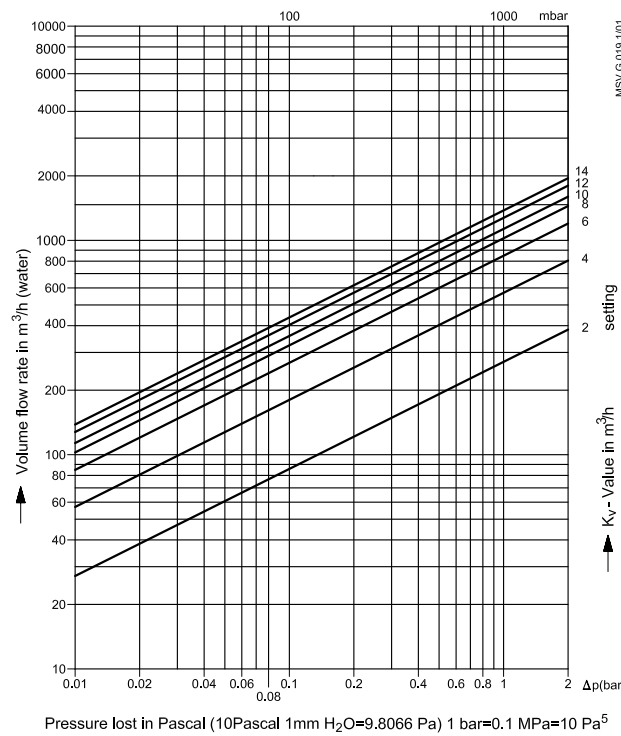

DN 300 / PN 25

Setting	k _v -value
2	270.9
4	575.8
6	856.0
8	1035.9
10	1142.8
12	1273.7
14	1380.2

Max. permissible differential pressure in throttling function 2.0 bar.

Max. permissible flow speed: ≤ 4 m/s

Condition:

- The flow must be free of cavitation.

Flow characteristic

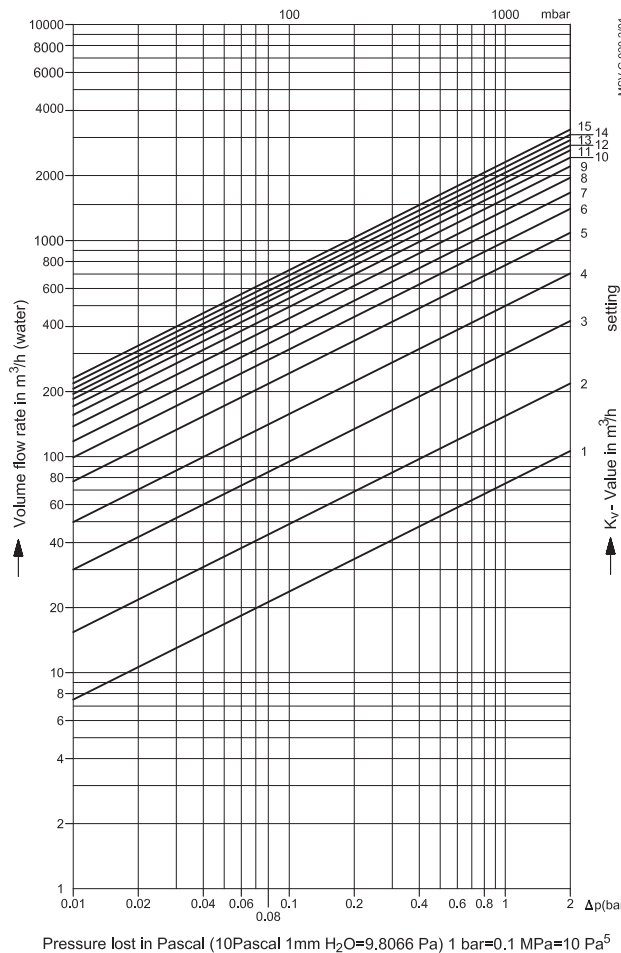
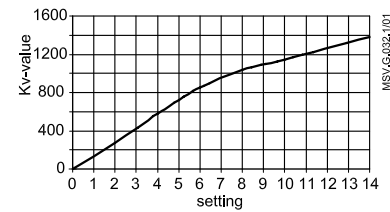

DN 350 / PN 16

Setting	k _v -value	Setting	k _v -value
1	75.1	9	1559
2	154	10	1711
3	300	11	1848
4	498	12	1952
5	768	13	2059
6	991	14	2182
7	1177	15	2305
8	1382	15.4	2359

Max. permissible differential pressure in throttling function 1.5 bar.

Max. permissible flow speed: ≤ 4 m/s

Condition:

- The flow must be free of cavitation.

Flow characteristic

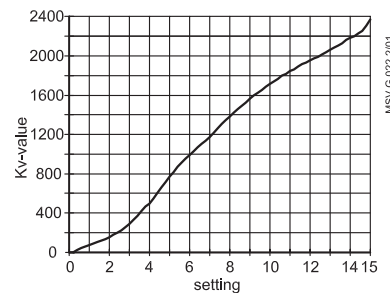

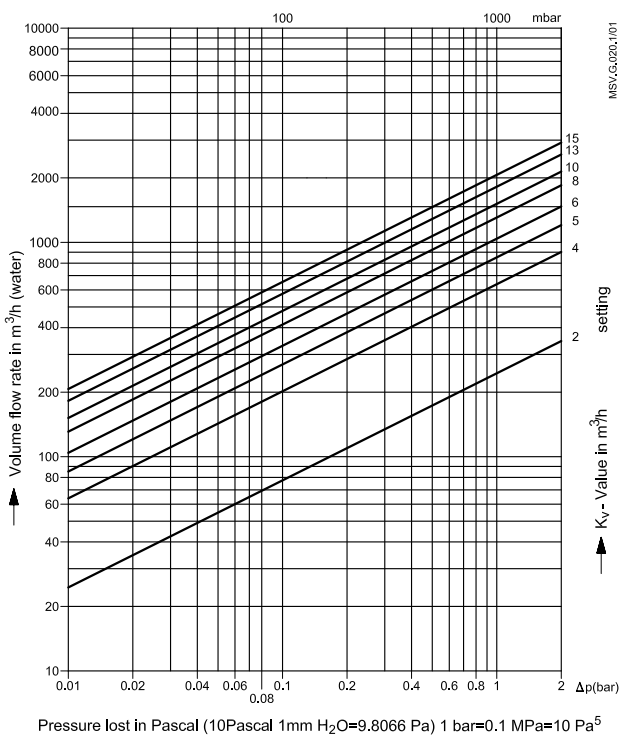

DN 350 / PN 25

Setting	k _v -value
2	249.06
4	634.4
5	844.72
6	1041.93
8	1369.45
10	1580.67
13	1844.74
15	2046.14

Max. permissible differential pressure in throttling function 2.0 bar.

Max. permissible flow speed: ≤ 4 m/s

Condition:

- The flow must be free of cavitation.

Flow characteristic

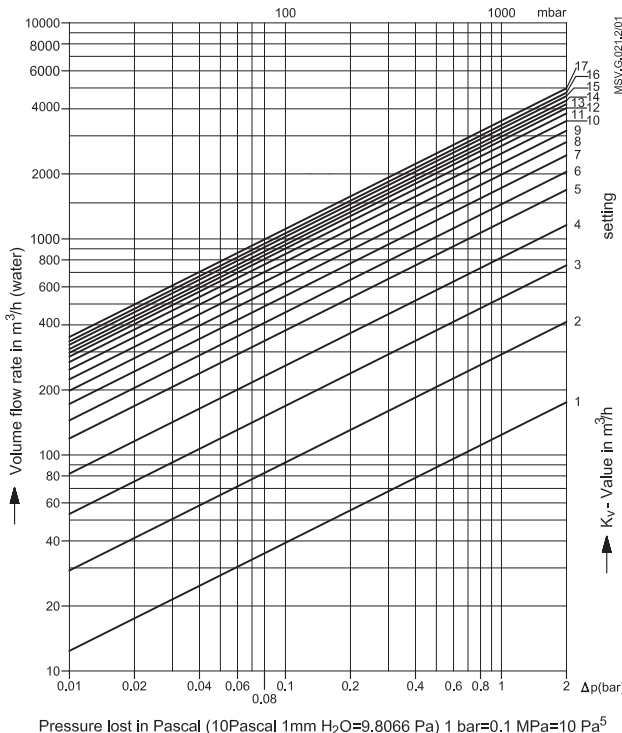
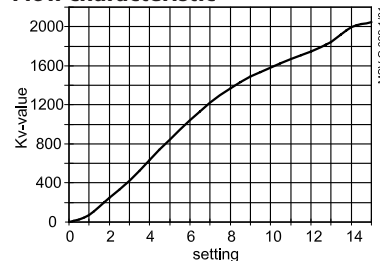

DN 400 / PN 16

Setting	k _v -value	Setting	k _v -value
0	0	9	2223
1	124	10	2482
2	292	11	2682
3	533	12	2848
4	819	13	2973
5	1192	14	3093
6	1445	15	3241
7	1720	16	3359
8	1983	Max: 17	3516

Max. permissible differential pressure in throttling function 1.5 bar.

Max. permissible flow speed: ≤ 4 m/s

Condition:

- The flow must be free of cavitation.

Flow characteristic

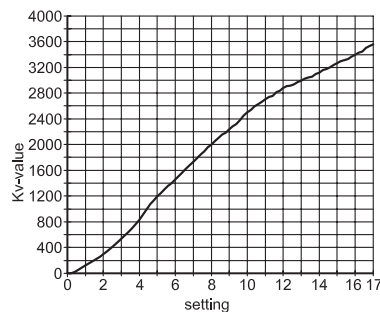

Flow diagrams (continued)

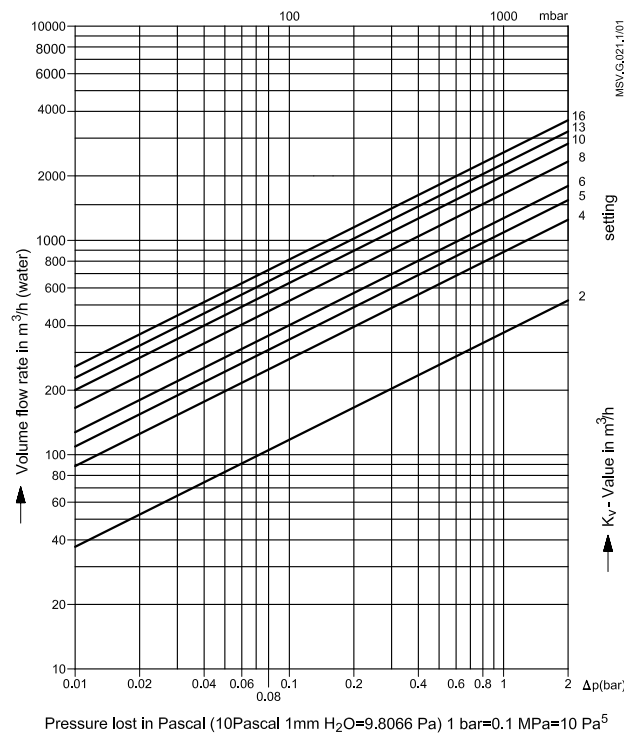

DN 400 / PN 25

Setting	k _v -value
2	371.75
4	875.26
5	1109.31
6	1328.86
8	1705.24
10	1980.56
13	2287.81
16	2584.95

Max. permissible differential pressure in throttling function 2.0 bar.

Max. permissible flow speed: ≤ 4 m/s

Condition:

- The flow must be free of cavitation.

Flow characteristic

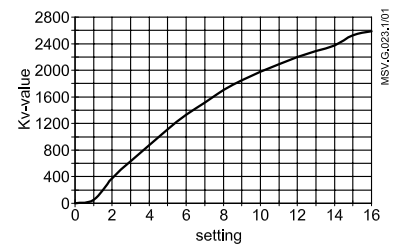

Dimensions

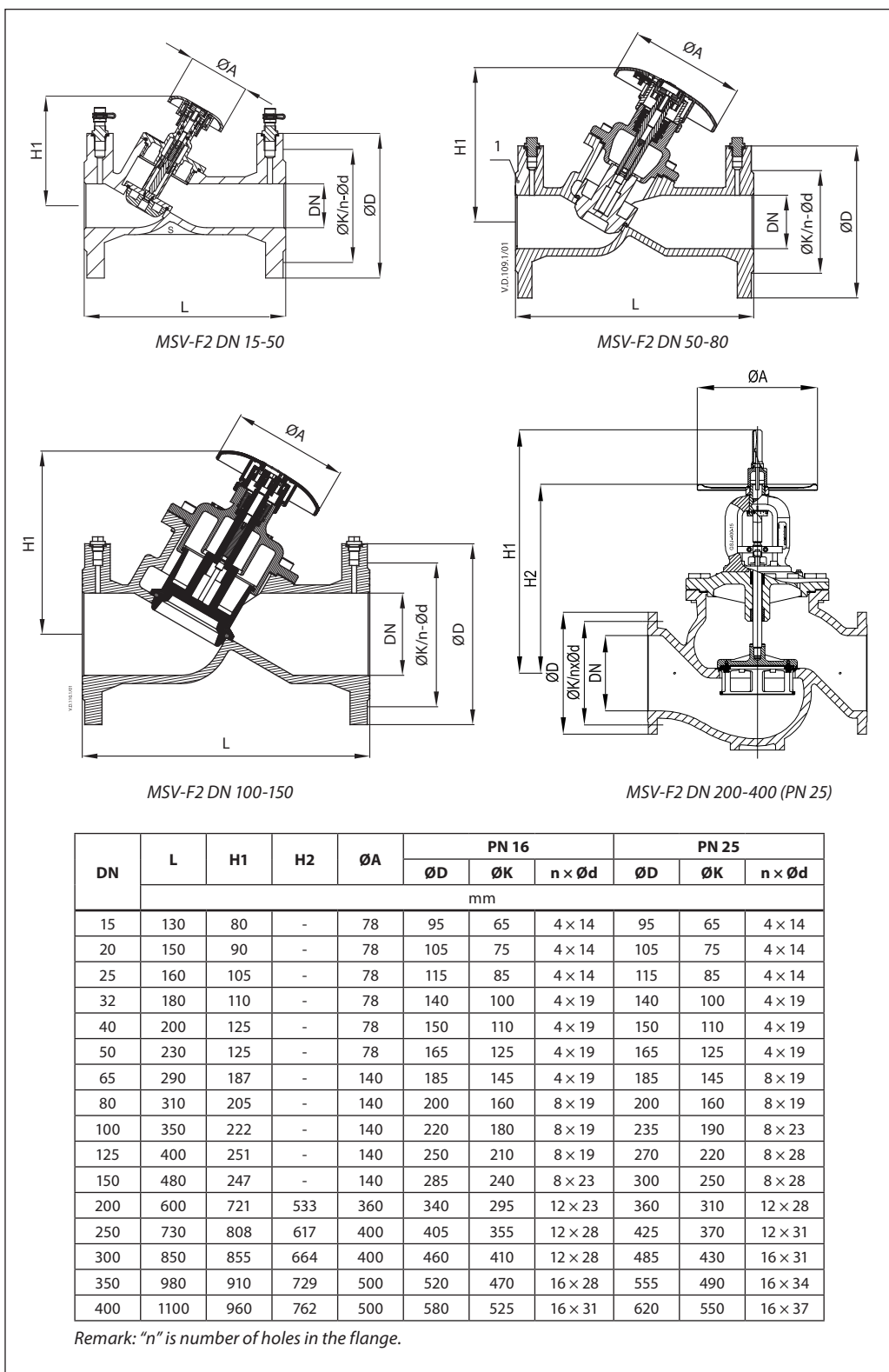

Dimensions (continued)

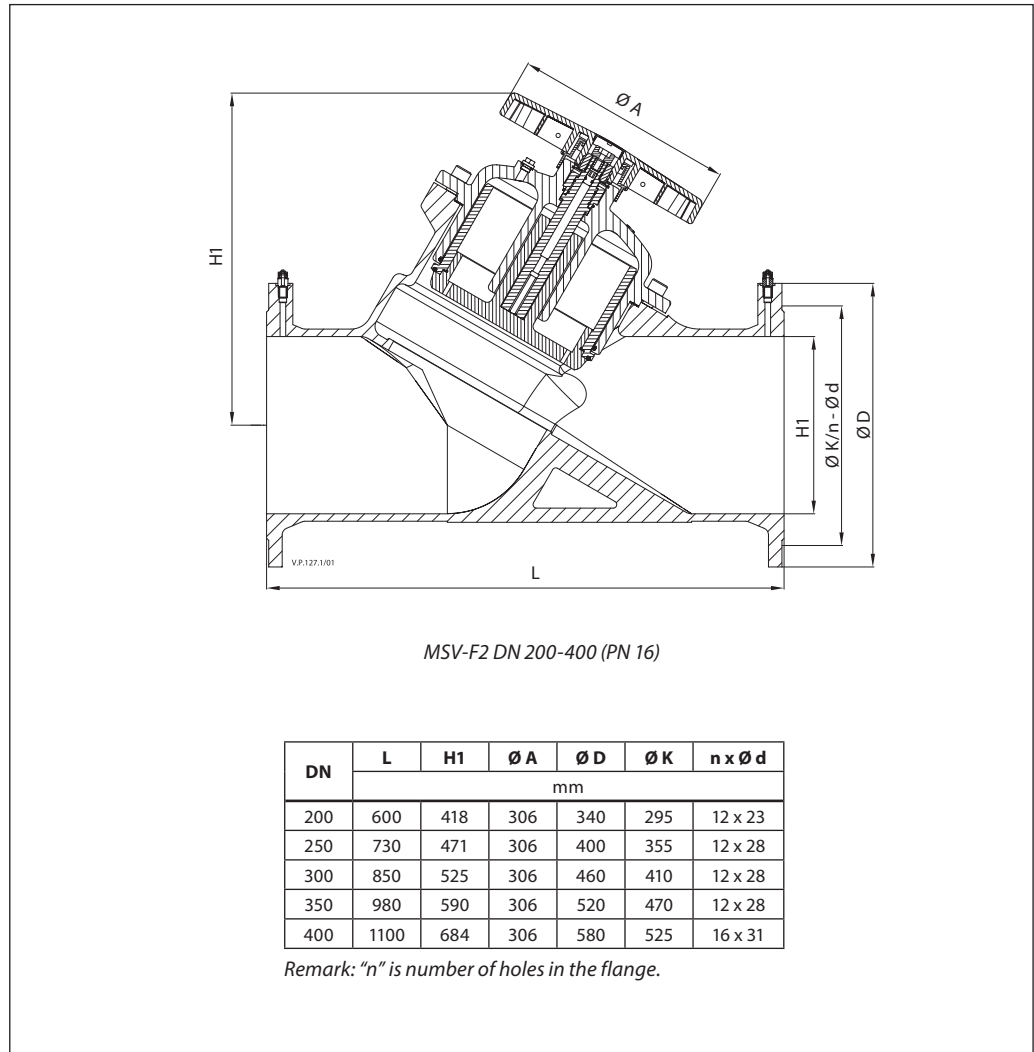

Danfoss A/S

Climate Solutions • danfoss.com • +45 7488 2222

Any information, including, but not limited to information on selection of product, its application or use, product design, weight, dimensions, capacity or any other technical data in product manuals, catalogues descriptions, advertisements, etc. and whether made available in writing, orally, electronically, online or via download, shall be considered informative, and is only binding if and to the extent, explicit reference is made in a quotation or order confirmation. Danfoss cannot accept any responsibility for possible errors in catalogues, brochures, videos and other material. Danfoss reserves the right to alter its products without notice. This also applies to products ordered but not delivered provided that such alterations can be made without changes to form, fit or function of the product.

All trademarks in this material are property of Danfoss A/S or Danfoss group companies. Danfoss and the Danfoss logo are trademarks of Danfoss A/S. All rights reserved.