

Data sheet

Valves for Control of Fan Coils and Terminal Units RA-HC

Description

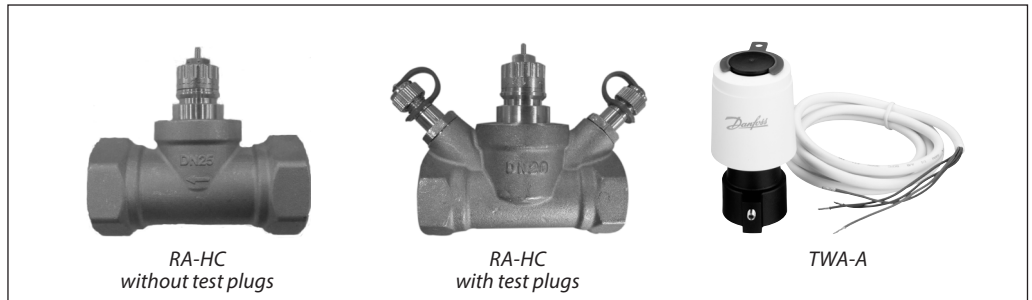

The RA-HC is a control valve applied together with Danfoss self-acting or Danfoss electronic controls in fan coil units and similar terminal units in any HVAC system. When installed with Danfoss ASV, balancing and control functions are combined representing the complete dynamic hydraulic solution.

Combined with Danfoss thermo actuators (TWA) the RA-HC valves provide On/Off control, control the flow over the terminal unit and maintain optimum temperatures based on room load requirements.

RA-HC valves have eight presettings, thus the correct quantity of water flow is ensured for each circuit.

RA-HC matches high flow capacities and with its compact design only little installation space is required.

The RA-HC with TWA and ASV provide:

- Balancing and control function
- High flow capacity
- Compact design, requires small installation space
- Easy presetting, no tools required
- Measuring on ASV partner valve or optional on RA-HC
- Shut-off (for isolation during system maintenance) using manual shut off knob.

Ordering and Specification

RA-HC valve

Type	Connection (")	Test plugs	Max working pressure	Max diff. Pressure with TWA-A	Medium Temp (°C)	Code No.
			bar			
DN 15	G ½	yes	16	1.8	-10 ... 100	003Z3931
DN 20	G ¾	yes	16	1.8	-10 ... 100	003Z3910
DN 25	G 1	yes	16	1.8	-10 ... 100	003Z3911
DN 15	G ½	no	16	1.8	-10 ... 100	003Z3932
DN 20	G ¾	no	16	1.8	-10 ... 100	003Z3920
DN 25	G 1	no	16	1.8	-10 ... 100	003Z3921

The max. differential pressure specified is the maximum pressure at which the valves give satisfactory regulation. As with any device which imposes a pressure drop on the system, noise may occur under certain flow/pressure conditions.

RA-HC accessories

Type	Connection type	Supply Voltage	Code No.
TWA-A NC	RA	24 V AC/DC	088H3110
TWA-A NO			088H3111
TWA-A NC		230 V AC	088H3112
TWA-A NO			088H3113
Manual shut off knob	-	-	013G3300

Valve	Presettings, k_v values ¹⁾														k_{vs}
	1	1.5	2	2.5	3	3.5	4	4.5	5	5.5	6	6.5	7	N	
DN 15	0.11	0.16	0.22	0.28	0.41	0.62	0.82	1.0	1.2	1.3	1.5	1.7	2.0	2.8	2.8
DN 20	0.29	0.34	0.43	0.68	0.88	1.1	1.3	1.4	1.7	2.2	2.8	3.1	3.3	4.3	4.3
DN 25	0.35	0.41	0.58	0.79	1.0	1.3	1.5	1.7	2.2	2.9	3.7	3.9	4.0	5.5	5.5

¹⁾ The k_v -values show the flow (Q) in m³/h at a differential pressure (Δp) of 1 bar through the valve.

System and Flow Verification

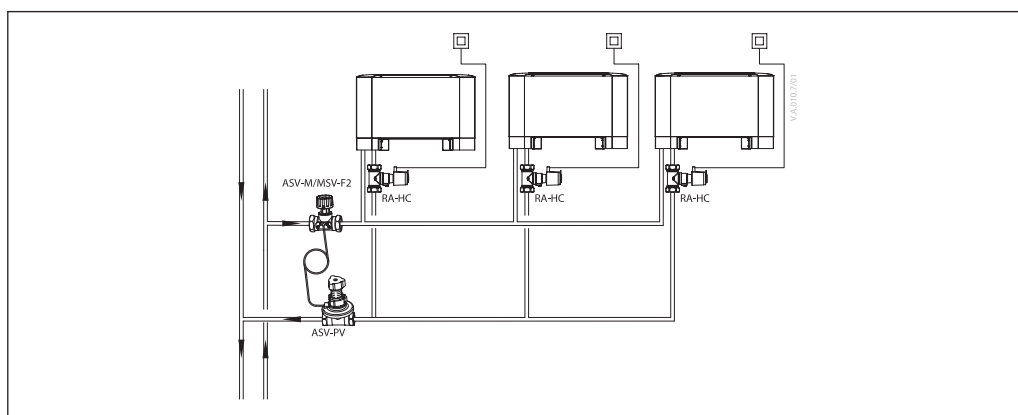

For RA-HC without test plugs, it is recommended to do measuring and flow verification with Danfoss PFM 5001 or Danfoss flow indicator on the ASV-PV partner valve.

For detailed information on:

- ASV-PV data sheet
- PFM 5001 data sheet
- Flow indicator data sheet

For ASV-PV < DN 50 the recommended partner valve is ASV-I or ASV-BD. For ASV-PV > DN 50 the recommended partner valve is MSV-F2.

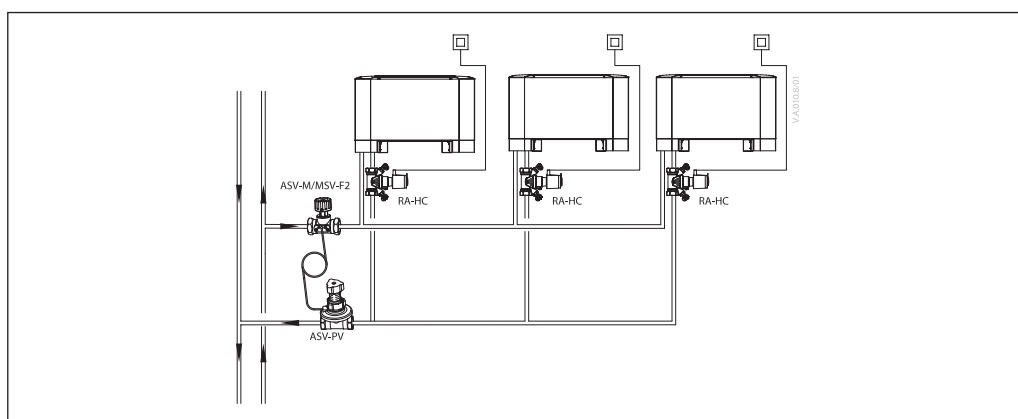

For RA-HC with test plugs, it is accepted to do measuring and flow verification with Danfoss PFM 5001 or Danfoss flow indicator on the RA-HC valve directly.

For detailed information on:

- ASV-PV data sheet
- PFM 5001 data sheet
- Flow indicator data sheet

For ASV-PV < DN 50 the recommended partner valve is ASV-M or ASV-BD.

For ASV-PV > DN 50 the recommended partner valve is MSV-F2.

Design

1. Gland seal
2. Protection cap
3. Valve head
4. Test plugs
5. Sealing pad
6. Valve body

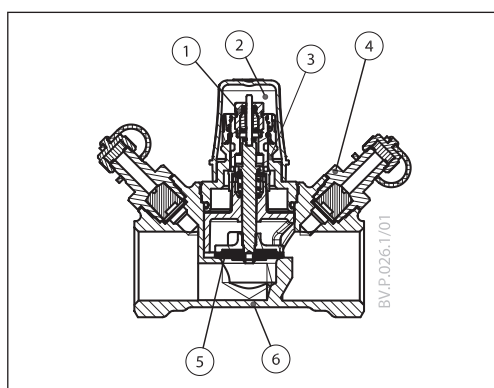

Materials in contact with flow medium ¹⁾

Valve body and other metal parts	DZR
Cone	DZR
O-rings	EPDM
Sealing pad	NBR
k _v -setting ring	Ryton PPS

¹⁾ **Flow medium:** water and water mixtures with secondary coolants like glycols (regarding suitability and usage especially in not oxygen tight systems please see the instructions given by the coolant producer).

Capacities

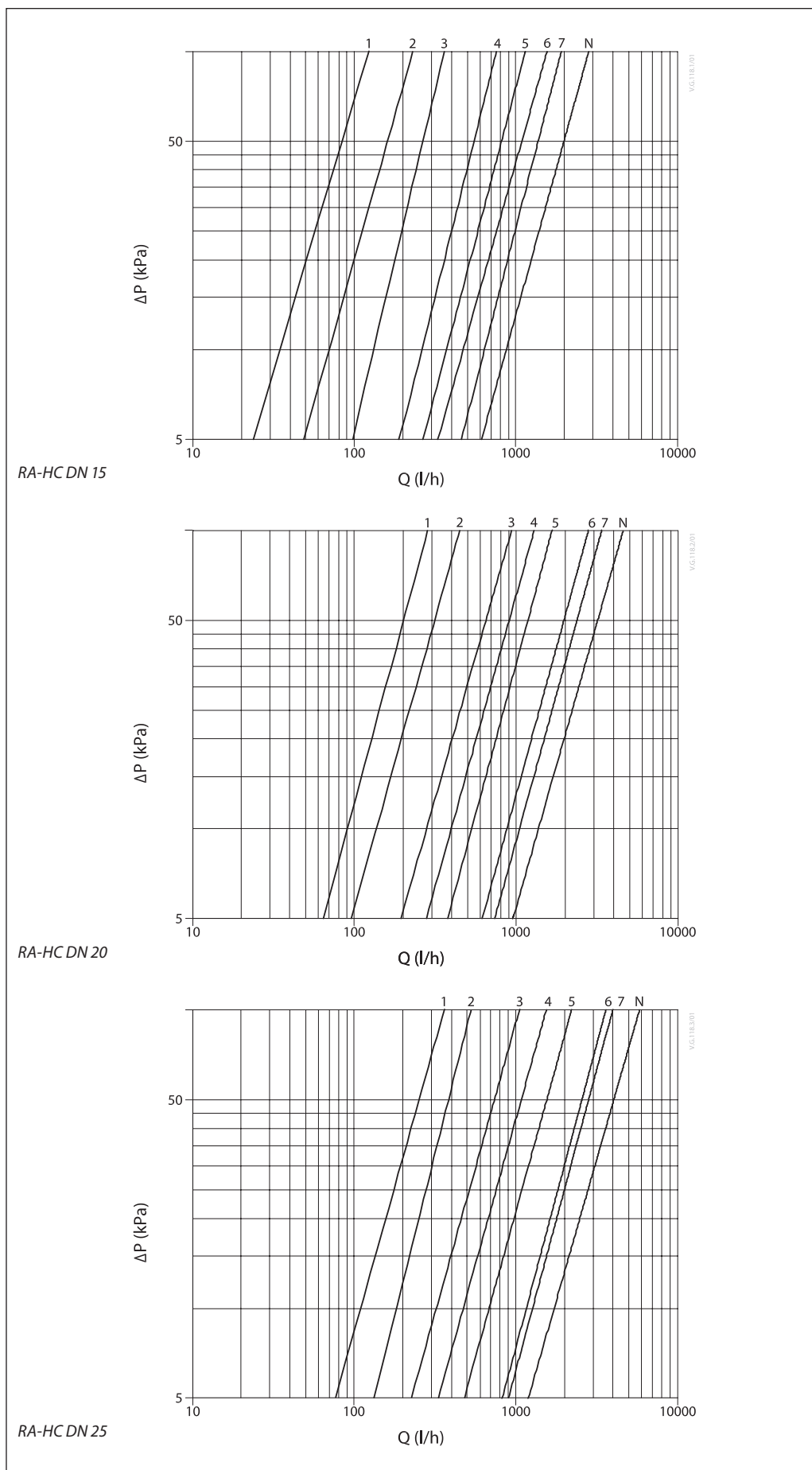

Data sheet

RA-HC Valves for Control of Fan Coils and Terminal Units

Presetting

The calculated setting can be set easily and exactly without using special tools:

- remove the protective cap or sensor element
- raise the setting ring
- turn the scale on the setting ring (anticlockwise) until the required scale value faces the reference mark *
- release the setting ring

* with the factory setting of the valve is N.

The presetting can be set at the values: 1-7 and N. At setting N, the valve is completely open.

A setting in the shaded areas should be avoided.

When the sensor element is mounted, the presetting is hidden, and is thus protected against alteration.

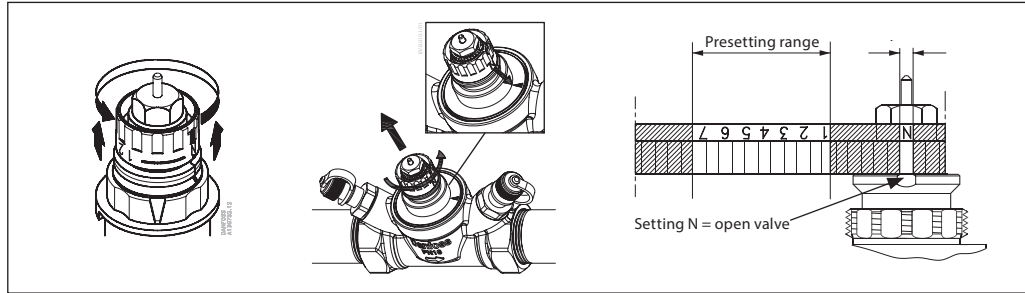

Pressure and Noise Conditions

Special demands are made on the various components of the system. This is due to water temperature conditions, the chosen pipe types and pipe dimensions of fancoils/induction units and the structure of the cooling circuits.

In chilled ceilings and fancoils/induction-units relatively large differential pressure and water flow are often used compared to normal heating systems. This may lead to noise nuisance.

The RA-HC valve has especially been designed to correspond to these demands, no matter whether self-acting or electronic controls are used.

Dimensions

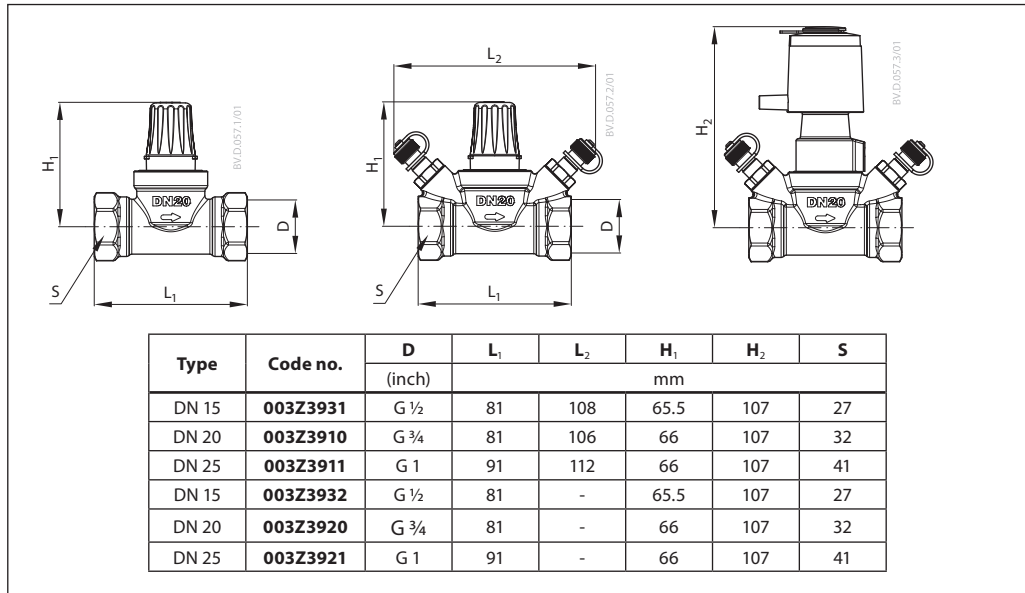

Danfoss A/S

Climate Solutions • danfoss.com • +45 7488 2222

Any information, including, but not limited to information on selection of product, its application or use, product design, weight, dimensions, capacity or any other technical data in product manuals, catalogues descriptions, advertisements, etc. and whether made available in writing, orally, electronically, online or via download, shall be considered informative, and is only binding if and to the extent, explicit reference is made in a quotation or order confirmation. Danfoss cannot accept any responsibility for possible errors in catalogues, brochures, videos and other material. Danfoss reserves the right to alter its products without notice. This also applies to products ordered but not delivered provided that such alterations can be made without changes to form, fit or function of the product.

All trademarks in this material are property of Danfoss A/S or Danfoss group companies. Danfoss and the Danfoss logo are trademarks of Danfoss A/S. All rights reserved.