

Stålkulventiler, reducerat genomlopp

invändiga gängor / svetsning EN (DIN), DN 10-50

Ventilhus	DN 10-50 Stål, P235GH (1.0345)
Kultätning	DN 10-50 PTFE+C
Spindeltätning	DN 10-50 FPM
Spindel	DN 10-50 Rostfritt stål, X8CrNiS18-9 (1.4305)
Kula	DN 10-50 Rostfritt stål, X5CrNi18-10 (1.4301)
Manövrering	DN 10-50 Med förzinkat stål handtag



Funktionsvillkor

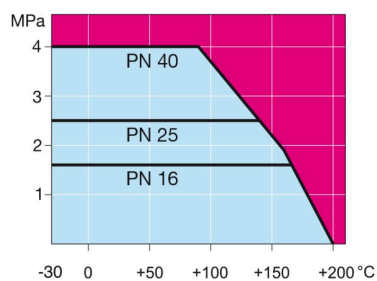

Ej för ånga

DN 10-50

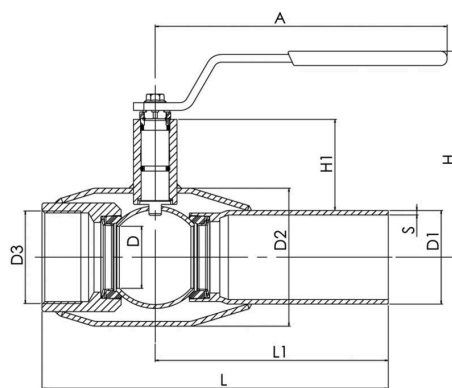

DN	PN	Product no. Naval	A	D	D1	D2	D3	H	H1	L	L1	S	kg
10	40	284002	145	10	17.2	33.7	R 3/8	98	22	153	115	2	0.6
15	40	284003	145	10	21.3	33.7	R 1/2	98	22	158	115	2	0.6
20	40	284005	145	15	26.9	42.4	R 3/4	103	23	165	115	2,3	0.8
25	40	284006	145	20	33.7	48.3	R 1	118	34	172	115	2,6	1.1
32	40	284007	145	25	42.4	60.3	R 1 1/4	121	33	195	130	2,6	1.4
40	40	284008	188	32	48.3	70.0	R 1 1/2	120	43	205	130	2,6	1.9
50	40	284009	188	40	60.3	88.9	R 2	127	44	240	150	2,9	2.7