

PN16, carbon steel, lap joint flange EN1092-1 (DIN2501)  
DN125  
LINER: Polyurethane

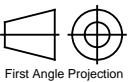
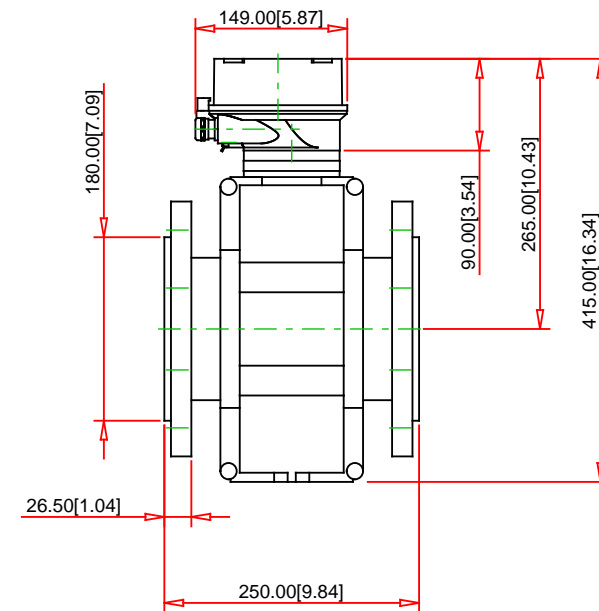

**Disclaimer:**

To ensure the accuracy of the information contained in this document every reasonable effort has been made. Endress+Hauser may not make any warranties, express or implied, with respect to the accuracy, the completeness or the technical or commercial usefulness of this document. Endress+Hauser may modify or replace this document any time.

© 09.11.2018 Endress+Hauser

Order Code :  
5L4C1Z-AALHN0AUD320A+L1

Product Description :  
Promag L 400, 5L4C1Z, DN125

[www.addresses.endress.com](http://www.addresses.endress.com)



People for Process Automation