

PN 16 - DN 50...300

KAT-A 1030-PE-W

Product characteristics and benefits

- Resilient seated in accordance with EN 1074 (DIN 3352 - 4A)
- With PE-HD ends on both sides acc. to SDR 11
- Low operating torque due to plastic sliding guides on the wedge
- Maintenance-free and corrosion-resistant stem sealing
- With triple O-ring sealing
- Low wear due to wedge guiding and elongated stem bearing
- Designed for mirror welding and electro-fusion welding
- Extended welding ends for a second electro-fusion welding on both sides
- With integrated adapter for the TELEMAX[®] stem extension

Materials

- Body: Ductile iron EN-GJS-400-15 (GGG-40)
- Bonnet: Ductile iron EN-GJS-400-15 (GGG-40)
- Wedge: Ductile iron EN-GJS-400-15 (GGG-40) encapsulated with EPDM vulcanized
- Bonnet bolts: Stainless steel A2 (DIN EN ISO 3506)
- PE-HD ends: PE 100
- Stem: Stainless steel 1.4057
- Stem nut: Brass

Corrosion protection

- Internally and externally epoxy coated acc. to GSK guidelines

Versions

- Standard version as described
- With handwheel

Field of application

- Underground installation

**Tests and approvals**

- Final inspection test according to EN 12266-1 (leakage rate A)
- DVGW tested and registered (up to outer diameter 225)
- Elastomers approved acc. to W270

Accessories

- T-key
- Installation equipment
- Extension spindle
- Surface box cast iron
- Plastic base plate
- VAG SERIO[®]plus position indicator

Note

For proper installation and safe operation please follow the installation and operation instructions:

“Installation and Operating Instructions for Valves”

Field of application

DN	PN	Maximum operating pressure [bar]	Maximum operating temperature for neutral liquids [°C]
50...300	16	16	50

* Stem material will be changed from 1.4021 to 1.4057

Drawing

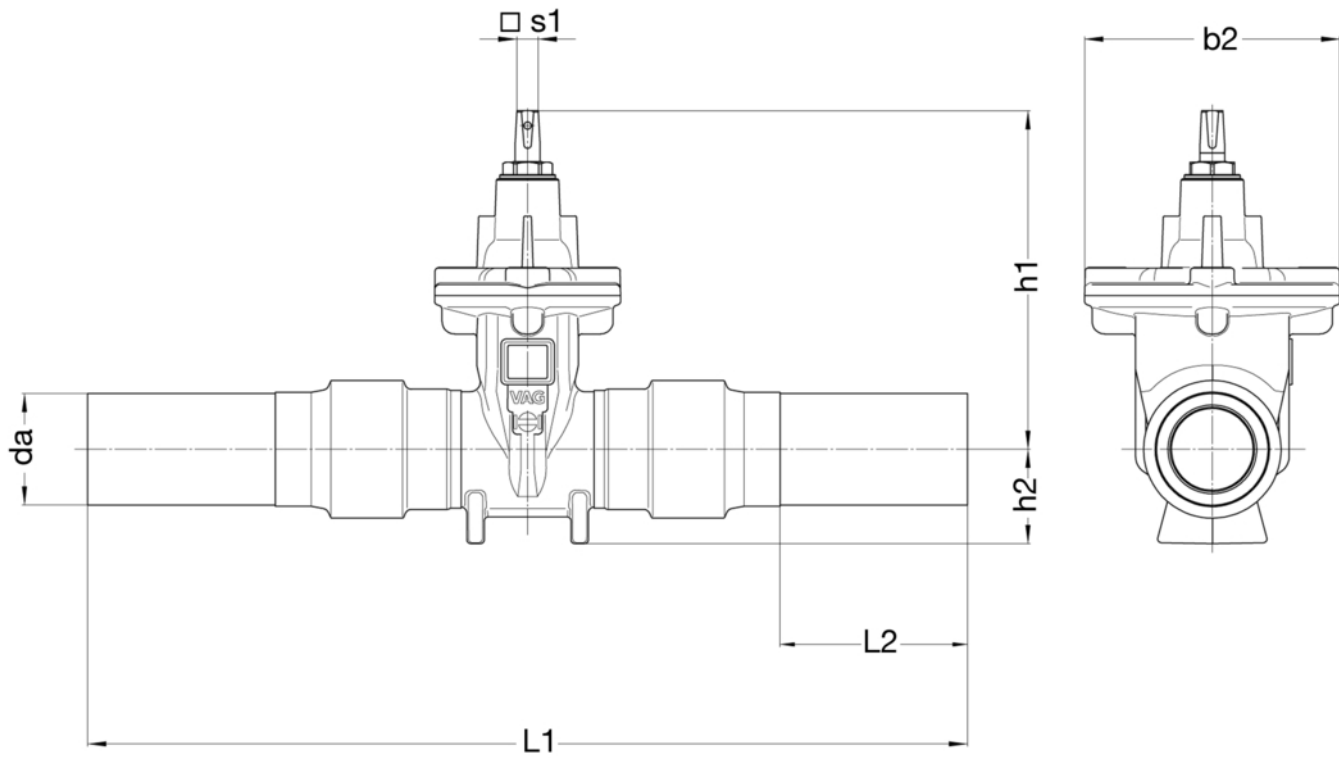

Technical data

PN 16

DN		50	80	100	100	125	150	150	200	200	250	250	300
da	[mm]	63	90	110	125	140	160	180	200	225	250	280	315
L1	[mm]	566	740	775	775	862	902	982	1099	1129	1388	1428	1520
L2	[mm]	132	164	170	180	190	202	216	230	246	264	284	306
b2	[mm]	121	206	206	206	228	252	252	330	330	413	413	472
h1	[mm]	233	278	310	310	347	386	386	493	493	606	606	670
h2	[mm]	50	76	85	85	94	110	110	149	149	172	172	198
s1	[mm]	14	17	19	19	19	19	19	24	24	27	27	27
Turns/stroke		14.5	21.5	21.5	21.5	26.5	32	32	34	34	43	43	51
Weight approx.	[kg]	8.20	15.50	20.30	23.00	31.40	42.50	46.10	79.20	85.50	166.00	164.00	212.00
Volume approx.	[m ³]	0.02	0.055	0.067	0.067	0.093	0.115	0.115	0.232	0.24	0.446	0.459	0.61