

PN 10/16 - DN 40...300

KAT-A 1010-F4-EW

Product characteristics and benefits

- Resilient seated in accordance with EN 1074 (DIN 3352 - 4A)
- Face-to-face length acc. to EN 558, basic series 14 (DIN 3202, F4)
- With flange ends on both sides acc. to EN 1092-2
- Boltless bonnet with pressure supported sealing system
- Low operating torque due to plastic sliding guides on the wedge
- Maintenance-free and corrosion-resistant stem sealing
- With O-ring sealing
- Low wear due to wedge guiding and elongated stem bearing
- Suitable for vacuum of up to 90%

Materials

- Body: Ductile iron EN-GJS-400-15 (GGG-40)
- Bonnet: Ductile iron EN-GJS-400-15 (GGG-40)
- Wedge: Ductile iron EN-GJS-400-15 (GGG-40) encapsulated with EPDM vulcanized
- Stem: Stainless steel 1.4057
- Stem nut: Brass

Corrosion protection

- Internally and externally epoxy coated acc. to GSK guidelines

Versions

- Standard version as described
- With handwheel

Field of application

- Underground installation
- Chamber installation



Tests and approvals

- Final inspection test according to EN 12266-1 (leakage rate A)
- DVGW tested and registered
- Elastomers approved acc. to W270

Accessories

- T-key
- Installation equipment
- Extension spindle
- Surface box cast iron
- Plastic base plate
- VAG SERIO®*plus* position indicator

Note

For proper installation and safe operation please follow the installation and operation instructions:

“Installation and Operating Instructions for Valves”

Field of application

DN	PN	Maximum operating pressure [bar]	Maximum operating temperature for neutral liquids [°C]
40...300	16	16	50
200...300	10	10	50

Drawing

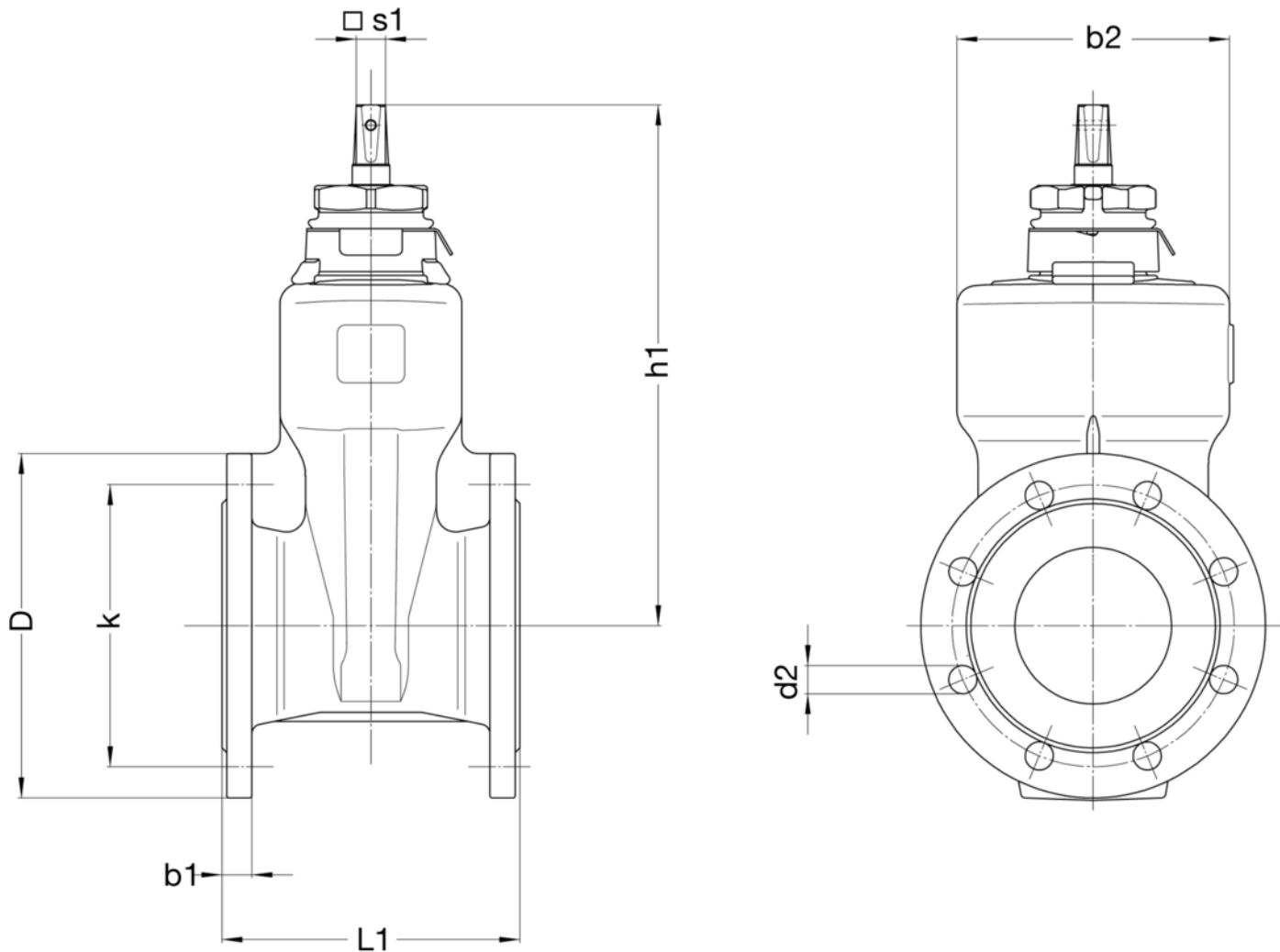

Technical data

PN 10

DN		200	250	300
D	[mm]	340	400	455
k	[mm]	295	350	400
L1	[mm]	230	250	270
b1	[mm]	20	22	24.5
b2	[mm]	320	396	471
d2	[mm]	23	23	23
h1	[mm]	523	633	713
s1	[mm]	24	27	27
No. of holes		8	12	12
Turns/stroke		34	43	51
Weight approx.	[kg]	68.00	109.00	155.50
Volume approx.	[m ³]	0.06	0.1	0.14

Technical data
PN 16

DN	40	50	65	80	100	125	150	200	250	300
D [mm]	150	165	185	200	220	250	285	340	400	455
k [mm]	110	125	145	160	180	210	240	295	355	410
L1 [mm]	140	150	170	180	190	200	210	230	250	270
b1 [mm]	19	19	19	19	19	19	19	20	22	24.5
b2 [mm]	125	125	160	160	174	220	246	320	396	471
d2 [mm]	19	19	19	19	19	19	23	23	28	28
h1 [mm]	245	245	280	280	334	379	417	523	633	713
s1 [mm]	14	14	17	17	19	19	19	24	27	27
No. of holes	4	4	4	8	8	8	8	12	12	12
Turns/stroke	11	13.5	16	20	20	25	30	34	43	51
Weight approx. [kg]	10.00	10.50	15.50	17.00	22.50	31.50	40.50	68.00	109.00	155.50
Volume approx. [m ³]	0.01	0.01	0.015	0.015	0.02	0.03	0.04	0.06	0.1	0.14