



## PN 10/16 - DN 40...300

KAT-A 1544

### Product characteristics and benefits

- Resilient seated in accordance with EN 16767
- Face-to-face length acc. to EN 558, basic series 48 (DIN 3202, F6)
- With flange ends on both sides acc. to EN 1092-2
- Low pressure loss due to full bore type (100%)
- Double service life due to turnable disk
- Integrated limit stops in the disk to protect the seal
- No bearing friction due to integrated suspension of disk
- Pre-stressed disk closing due to rubber suspension
- Incrustation- and corrosion-free rubber lined disk
- Quick and easy disassembly of body cover and disk for maintenance
- With threaded plug G 3/4"

### Materials

- Body: Ductile iron EN-GJS-400-15 (GGG-40)
- Bonnet: Ductile iron EN-GJS-400-15 (GGG-40)
- Check valve disk: Ductile iron EN-GJS-400-15 (GGG-40) encapsulated with EPDM vulcanized
- Bonnet bolts: Stainless steel A2 (DIN EN ISO 3506)
- Plug: Brass

### Corrosion protection

- Internally and externally epoxy coated acc. to GSK guidelines

### Versions

- Standard version as described
- With disk lifting device G 3/4" (also retrofittable)
- Suitable for seawater

### Field of application

- Installation in plants



### Tests and approvals

- Final inspection test according to 1074-3, EN 12266-1 (leakage rate A)
- Elastomers approved acc. to W270

### Accessories

- Disk lifting device

### Note

For proper installation and safe operation please follow the installation and operation instructions:  
KAT-B 1544

### Field of application

DN	PN	Maximum operating pressure [bar]	Maximum operating temperature for neutral liquids [°C]
40...300	16	16	50
200...300	10	10	50



## Drawing

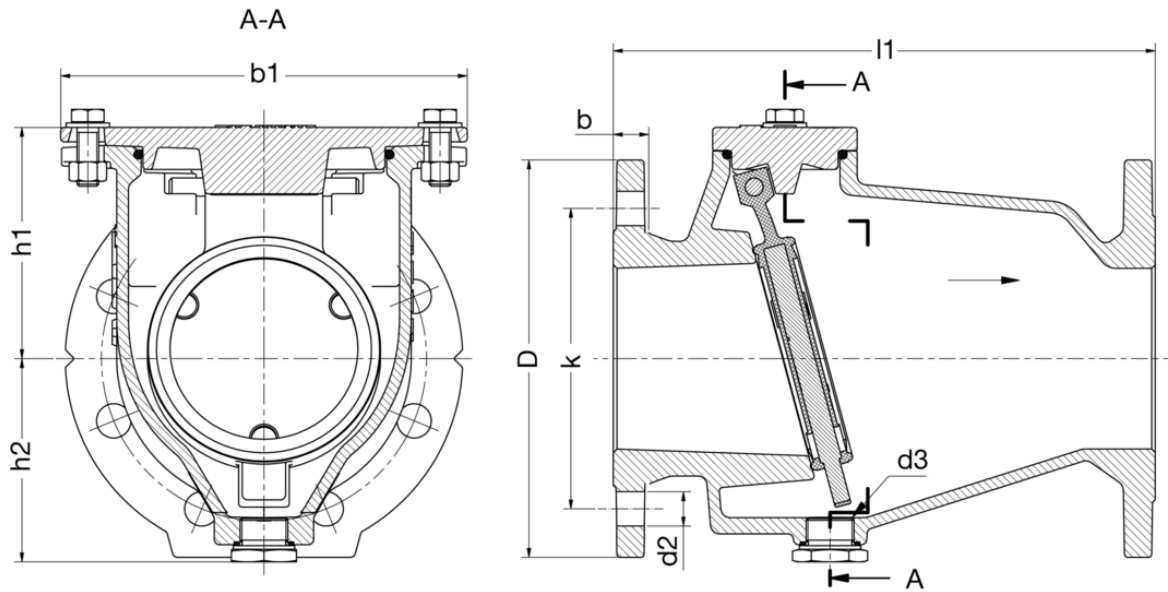

## Lifting device

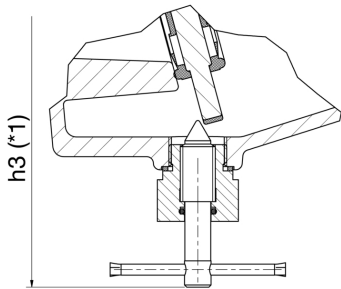

\*1: Dimension up to centre of valve

Lifting device (can be replaced by threaded plug)

- DN 40...100: 1,5 bar - maximum pressure for lifting
- DN 125...200: 0,75 bar - maximum pressure for lifting
- DN 250...300: 0,25 bar - maximum pressure for lifting

## Technical data

### PN 10

DN		200	250	300
D	[mm]	340	400	455
b	[mm]	20	22	24.5
k	[mm]	295	350	400
b1	[mm]	400	490	550
d2	[mm]	23	23	23
h1	[mm]	237	291	336
h2	[mm]	185	210	235
h3	[mm]	225	250	275
l1	[mm]	500	600	700
No. of holes		8	12	12
Thread d3	[inch]	3/4"	3/4"	3/4"
Weight approx.	[kg]	81.00	130.50	175.50
Volume approx.	[m <sup>3</sup> ]	0.085	0.13	0.19



Technical data

PN 16

DN		40	50	65	80	100	125	150	200	250	300
D	[mm]	150	165	185	200	220	250	285	340	400	455
b	[mm]	19	19	19	19	19	19	19	20	22	24.5
k	[mm]	110	125	145	160	180	210	240	295	355	410
b1	[mm]	145	160	185	200	225	310	340	400	490	550
d2	[mm]	19	19	19	19	19	19	23	23	28	28
h1	[mm]	90	95	115	125	138	173	193	237	291	336
h2	[mm]	75	82	90	100	113	138	148	185	210	235
h3	[mm]	115	120	130	140	152	178	185	225	250	275
l1	[mm]	180	200	240	260	300	350	400	500	600	700
No. of holes		4	4	4	8	8	8	8	12	12	12
Thread d3	[inch]	3/4"	3/4"	3/4"	3/4"	3/4"	3/4"	3/4"	3/4"	3/4"	3/4"
Weight approx.	[kg]	8.00	10.00	13.50	16.00	21.00	35.00	46.00	81.00	130.50	175.50
Volume approx.	[m <sup>3</sup> ]	0.005	0.006	0.01	0.015	0.03	0.04	0.05	0.085	0.13	0.19



## Further information

### Flow resistance coefficient

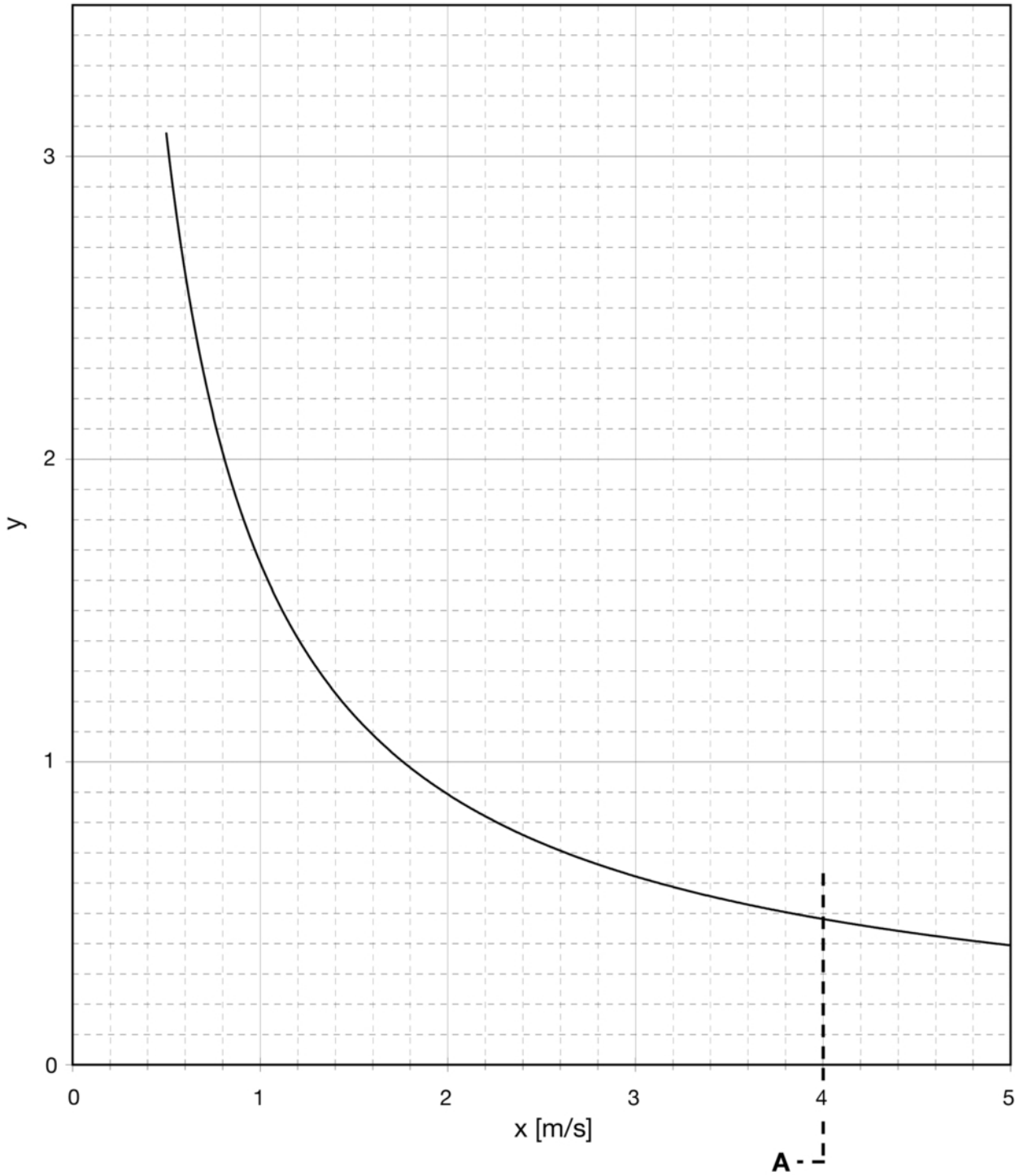

x: Flow velocity [m/s]  
y: Flow resistance coefficient  $\zeta$   
A: Operation limit