

High-efficiency Drinking Water Pump

Calio-Therm NC

Installation/Operating Manual



Legal information/Copyright

Installation/Operating Manual Calio-Therm NC

Original operating manual

All rights reserved. The contents provided herein must neither be distributed, copied, reproduced, edited or processed for any other purpose, nor otherwise transmitted, published or made available to a third party without the manufacturer's express written consent.

Subject to technical modification without prior notice.

© KSB SE & Co. KGaA, Frankenthal 08/03/2018

Contents

	Glossary	5
1	General.....	6
	1.1 Principles	6
	1.2 Target group.....	6
	1.3 Symbols	6
2	Safety.....	7
	2.1 Key to safety symbols/markings.....	7
	2.2 General.....	7
	2.3 Intended use	7
	2.4 Personnel qualification and training.....	8
	2.5 Consequences and risks caused by non-compliance with this manual	8
	2.6 Safety awareness	8
	2.7 Safety information for the operator/user	8
	2.8 Safety information for maintenance, inspection and installation	9
	2.9 Unauthorised modes of operation	9
3	Transport/Temporary Storage/Disposal.....	10
	3.1 Checking the condition upon delivery	10
	3.2 Transport.....	10
	3.3 Storage/preservation	10
	3.4 Return to supplier.....	10
	3.5 Disposal	11
4	Description of the Pump (Set).....	12
	4.1 General.....	12
	4.2 Description.....	12
	4.3 Name plate.....	12
	4.4 Design details.....	13
	4.5 Configuration and function.....	14
	4.6 Noise characteristics	14
	4.7 Scope of supply.....	14
	4.8 Dimensions and weight.....	14
5	Installation at Site.....	15
	5.1 Safety regulations.....	15
	5.2 Checks to be carried out prior to installation.....	15
	5.3 Installing the pump set	15
	5.4 Connecting the piping	16
	5.5 Casing/insulation	17
	5.6 Electrical connection	18
6	Commissioning/Start-up/Shutdown.....	20
	6.1 Commissioning/Start-up.....	20
	6.1.1 Prerequisites for commissioning/start-up	20
	6.1.2 Safety regulations	20
	6.1.3 Priming and venting the pump.....	20
	6.1.4 Start-up.....	21
	6.1.5 Mode of operation	22
	6.2 Shutdown.....	22
	6.3 Operating limits.....	22
	6.3.1 Ambient temperature.....	23
	6.3.2 Density of the fluid handled	23
	6.4 Shutdown/storage/preservation	23
	6.4.1 Measures to be taken for shutdown	23
	6.5 Returning to service	23

7	Servicing/Maintenance	24
7.1	Servicing/inspection	24
7.2	Drainage/cleaning	24
7.3	Removing the pump set from the piping	24
7.3.1	Safety regulations	24
7.3.2	Removing the complete pump set from the piping	25
8	Trouble-shooting	26
9	Related Documents	27
9.1	Wiring diagram.....	27
10	EU Declaration of Conformity	28
	Index	29

Glossary

Discharge line

The pipeline which is connected to the discharge nozzle

Pump

Machine without drive, additional components or accessories

Pump set

Complete pump set consisting of pump, drive, additional components and accessories

Suction lift line/suction head line

The pipeline which is connected to the suction nozzle

1 General

1.1 Principles

This operating manual is valid for the type series and variants indicated on the front cover.

The manual describes the proper and safe use of this equipment in all phases of operation.

The name plate indicates the type series and size as well as the main operating data. They uniquely identify the pump (set) and serve as identification for all further business processes.

In the event of damage, immediately contact your nearest KSB Service centre to maintain the right to claim under warranty.

1.2 Target group

This operating manual is aimed at the target group of trained and qualified specialist technical personnel. (⇒ Section 2.4, Page 8)

1.3 Symbols

Table 1: Symbols used in this manual

Symbol	Description
✓	Conditions which need to be fulfilled before proceeding with the step-by-step instructions
▷	Safety instructions
⇒	Result of an action
⇔	Cross-references
1. 2.	Step-by-step instructions
	Note Recommendations and important information on how to handle the product









2 Safety

All the information contained in this section refers to hazardous situations. In addition to the present general safety information the action-related safety information given in the other sections must be observed.

2.1 Key to safety symbols/markings

Table 2: Definition of safety symbols/markings

Symbol	Description
 DANGER	DANGER This signal word indicates a high-risk hazard which, if not avoided, will result in death or serious injury.
 WARNING	WARNING This signal word indicates a medium-risk hazard which, if not avoided, could result in death or serious injury.
 CAUTION	CAUTION This signal word indicates a hazard which, if not avoided, could result in damage to the machine and its functions.
	General hazard In conjunction with one of the signal words this symbol indicates a hazard which will or could result in death or serious injury.
	Electrical hazard In conjunction with one of the signal words this symbol indicates a hazard involving electrical voltage and identifies information about protection against electrical voltage.
	Machine damage In conjunction with the signal word CAUTION this symbol indicates a hazard for the machine and its functions.

2.2 General

This operating manual contains general installation, operating and maintenance instructions that must be observed to ensure safe operation of the system and prevent personal injury and damage to property.

The safety information in all sections of this manual must be complied with.

The operating manual must be read and understood by the responsible specialist personnel/operators prior to installation and commissioning.

The contents of this operating manual must be available to the specialist personnel at the site at all times.

Information attached directly to the product must always be complied with and kept in a perfectly legible condition at all times. This applies to, for example:

- Flow direction arrow
- Markings for connections
- Name plate

The operator is responsible for ensuring compliance with all local regulations not taken into account in this operating manual.

2.3 Intended use

- The pump (set) must only be operated in the fields of application and within the use limits specified in the other applicable documents.
- Only operate pumps/pump sets which are in perfect technical condition.
- Do not operate the pump (set) in partially assembled condition.
- Only use the pump to handle the fluids described in the data sheet or product literature of the pump model or variant.
- Never operate the pump without the fluid to be handled.

- Observe the minimum flow rate and maximum flow rate indicated in the data sheet or product literature (e.g. to prevent overheating, cavitation damage, bearing damage).
- Do not throttle the flow rate on the suction side of the pump (to prevent cavitation damage).
- Consult the manufacturer about any use or mode of operation not described in the data sheet or product literature.

2.4 Personnel qualification and training

All personnel involved must be fully qualified to transport, install, operate, maintain and inspect the machinery this manual refers to.

The responsibilities, competence and supervision of all personnel involved in transport, installation, operation, maintenance and inspection must be clearly defined by the operator.

Deficits in knowledge must be rectified by means of training and instruction provided by sufficiently trained specialist personnel. If required, the operator can commission the manufacturer/supplier to train the personnel.

Training on the pump (set) must always be supervised by technical specialist personnel.

2.5 Consequences and risks caused by non-compliance with this manual

- Non-compliance with these operating instructions will lead to forfeiture of warranty cover and of any and all rights to claims for damages.
- Non-compliance can, for example, have the following consequences:
 - Hazards to persons due to electrical, thermal, mechanical and chemical effects and explosions
 - Failure of important product functions
 - Failure of prescribed maintenance and servicing practices
 - Hazard to the environment due to leakage of hazardous substances

2.6 Safety awareness

In addition to the safety information contained in this manual and the intended use, the following safety regulations shall be complied with:

- Accident prevention, health regulations and safety regulations
- Explosion protection regulations
- Safety regulations for handling hazardous substances
- Applicable standards, directives and laws

2.7 Safety information for the operator/user

- Fit protective equipment (e.g. contact guards) supplied by the operator for hot, cold or moving parts, and check that the equipment functions properly.
- Do not remove any protective equipment (e.g. contact guards) during operation.
- Contain leakages (e.g. at the shaft seal) of hazardous fluids handled (e.g. explosive, toxic, hot) so as to avoid any danger to persons and the environment. Adhere to all relevant laws.
- Eliminate all electrical hazards. (In this respect refer to the applicable national safety regulations and/or regulations issued by the local energy supply companies.)
- If shutting down the pump does not increase potential risk, fit an emergency-stop control device in the immediate vicinity of the pump (set) during pump set installation.

2.8 Safety information for maintenance, inspection and installation

- Modifications or alterations of the pump (set) are only permitted with the manufacturer's prior consent.
- Use only original spare parts or parts/components authorised by the manufacturer. The use of other parts/components can invalidate any liability of the manufacturer for resulting damage.
- The operator ensures that maintenance, inspection and installation is performed by authorised, qualified specialist personnel who are thoroughly familiar with the manual.
- Only carry out work on the pump (set) during standstill of the pump.
- Only perform work on the pump set when it has been disconnected from the power supply (de-energised).
- The pump (set) must have cooled down to ambient temperature.
- Pump pressure must have been released and the pump must have been drained.
- When taking the pump set out of service always adhere to the procedure described in the manual. (⇒ Section 6.4, Page 23)
- Decontaminate pumps which handle fluids posing a health hazard.
- As soon as the work has been completed, re-install and re-activate any safety-relevant devices and protective devices. Before returning the product to service, observe all instructions on commissioning. (⇒ Section 6.1, Page 20)

2.9 Unauthorised modes of operation

Never operate the pump (set) outside the limits stated in the data sheet and in this manual.

The warranty relating to the operating reliability and safety of the supplied pump (set) is only valid if the equipment is used in accordance with its intended use.

3 Transport/Temporary Storage/Disposal

3.1 Checking the condition upon delivery



1. On transfer of goods, check each packaging unit for damage.
2. In the event of in-transit damage, assess the exact damage, document it and notify KSB or the supplying dealer and the insurer about the damage in writing immediately.

3.2 Transport

	CAUTION
	<p>Improper pump transport Damage to the pump!</p> <ul style="list-style-type: none"> ▷ Never suspend the pump/pump set from the power cable. ▷ Prevent the pump (set) from getting knocked or dropped.

3.3 Storage/preservation

If commissioning is to take place some time after delivery, we recommend that the following measures be taken for pump (set) storage.

	CAUTION
	<p>Damage during storage due to humidity, dirt, or vermin Corrosion/contamination of the pump (set)!</p> <ul style="list-style-type: none"> ▷ For outdoor storage cover the packed or unpacked pump (set) and accessories with waterproof material.
	CAUTION
	<p>Wet, contaminated or damaged openings and connections Leakage or damage to the pump!</p> <ul style="list-style-type: none"> ▷ Clean and cover pump openings and connections as required prior to putting the pump into storage.

Store the pump (set) in a dry, protected room where the atmospheric humidity is as constant as possible.



If properly stored indoors, the equipment is protected for a maximum of 12 months.

For storing a pump (set) which has already been operated, observe the instructions in (⇒ Section 6.4.1, Page 23) .

3.4 Return to supplier

1. Drain the pump as per operating instructions. (⇒ Section 7.2, Page 24)
2. Flush and clean the pump, particularly if it has been used for handling noxious, explosive, hot or other hazardous fluids.
3. If the pump has handled fluids whose residues could lead to corrosion damage in the presence of atmospheric humidity or could ignite upon contact with oxygen also neutralise the pump and blow through with anhydrous inert gas to ensure drying.
4. Always complete and enclose a certificate of decontamination when returning the pump.
Indicate any safety measures and decontamination measures taken.

3.5 Disposal

	 WARNING
	<p>Fluids handled, consumables and supplies which are hot and/or pose a health hazard</p> <p>Hazard to persons and the environment!</p> <ul style="list-style-type: none"> ▷ Collect and properly dispose of flushing fluid and any fluid residues. ▷ Wear safety clothing and a protective mask if required. ▷ Observe all legal regulations on the disposal of fluids posing a health hazard.

1. Dismantle the pump (set).
Collect greases and other lubricants during dismantling.
2. Separate and sort the pump materials, e.g. by:
 - Metals
 - Plastics
 - Electronic waste
 - Greases and other lubricants
3. Dispose of materials in accordance with local regulations or in another controlled manner.

4 Description of the Pump (Set)

4.1 General

- Non-self-priming in-line pump
- Handling clean or aggressive fluids not chemically and mechanically aggressive to the pump materials.

4.2 Description

Example: Calio-Therm NC 25-40-130

Table 3: Designation key

Code	Description
Calio	Type series
Therm	Drinking water pump
NC	Fixed speed
25	Nominal diameter of pump nozzle
	20 G 1 1/4
	25 G 1 1/2
40	Head in m x 10 (example: 40 = 4 m)
130	Length
	130 130 mm

4.3 Name plate

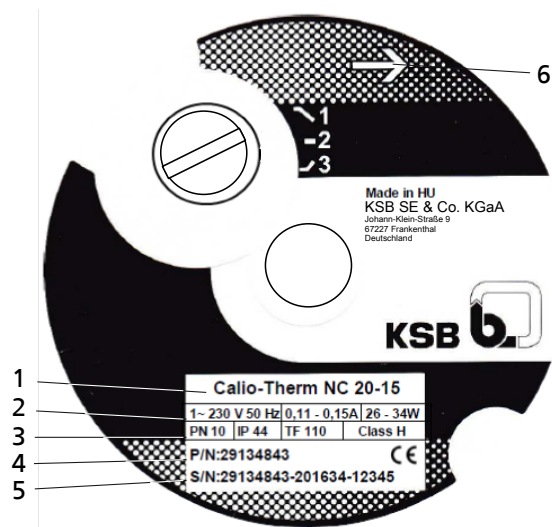

Fig. 1: Name plate (example)

1	Type series, size	2	Supply voltage and frequency, current input, electric input power
3	Pressure class, enclosure, temperature class of fluid handled, thermal class of motor	4	Material number
5	Serial number (Material number - Production date - Consecutive number)	6	Direction of rotation of the motor

Key to the serial number Example: 29134843-201634-12345

Table 4: Key to the serial number

Number	Description
2016	Year of production 2016
34	Week of production (calendar week) 34
12345	Consecutive number (reset to 0 at the beginning of each week of production)

4.4 Design details

Design

- Maintenance-free high-efficiency wet rotor pump (glandless)

Drive

- Electric motor
- Integrated motor protection
- 1~230 VAC, 50 Hz
- Enclosure IP44
- Thermal class F
- Temperature class TF 110
- Interference emissions EN 61000-6-3
- Interference immunity EN 61000-6-2

Bearings

- Product-lubricated special plain bearing

Connections

- Screw-ended

Operating modes

- Fixed speed operation with 3 speed levels

Automatic functions

- Soft start
- Full motor protection with integrated trip electronics

Manual functions

- Vent function
- Deblocking function
- Setting the speed level

Signalling and display functions

- None

4.5 Configuration and function

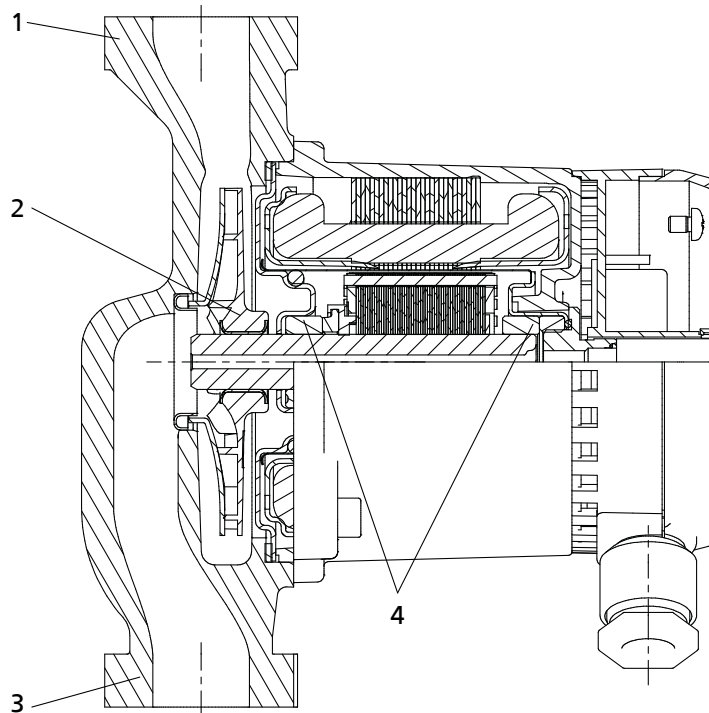

Fig. 2: Sectional drawing of the pump

1	Discharge nozzle	2	Impeller
3	Suction nozzle	4	Plain bearing

Design The pump is designed with a radial fluid inlet and a radial outlet arranged on the same axis. The impeller is firmly connected to the motor shaft. The fluid handled lubricates and cools the rotating assembly, which is isolated from the stator winding. All wetted parts are approved for use with drinking water. The impeller is made of plastic, the bearings of ceramics, and the motor shaft and pump casing of stainless steel. The motor housing made of aluminium is fastened to the pump casing with 4 screws. The front cover with integrated cable gland is fastened to the motor housing with two screws. When the screws have been undone the front cover can be removed to connect the power cable to the pump's terminals.

Function The fluid enters the pump via the suction nozzle (3) and is accelerated outward in a cylindrical flow by the rotating impeller (2). In the flow passage of the pump casing the kinetic energy of the fluid is converted into pressure energy. The fluid is pumped to the discharge nozzle (1). It leaves the pump via the discharge nozzle. The shaft runs in plain bearings (4) in the motor.

4.6 Noise characteristics

Table 5: Noise characteristics [dB A]

	Sound pressure level
All	max. 43

4.7 Scope of supply

- Pump set
- Seal elements for threaded connection
- Installation/operating manual
- Insulation shells (for 180 mm overall length only)

4.8 Dimensions and weight

For dimensions and weights please refer to the type series booklet of the pump (set).

5 Installation at Site

5.1 Safety regulations

	⚠ DANGER
	<p>Hazardous fluids / substances in the piping Risk of injury!</p> <ul style="list-style-type: none"> ▷ Flush and thermally disinfect the piping prior to commissioning the pump.
	⚠ DANGER
	<p>Installation in potentially explosive atmospheres Explosion hazard!</p> <ul style="list-style-type: none"> ▷ Never install the pump in potentially explosive atmospheres. ▷ Never use the pump to handle explosive fluids.

5.2 Checks to be carried out prior to installation

Before beginning with the installation check the following:

- The pump set can be operated on the power supply network according to the data on the name plate.
- The fluid to be handled matches the description of suitable fluids.

5.3 Installing the pump set

Install the pump set in an easily accessible place.

	CAUTION
	<p>Ingress of fluid into the motor Damage to the pump set!</p> <ul style="list-style-type: none"> ▷ Install the pump set with the pump shaft in a horizontal position. Connect the piping without transmitting any stresses and strains. ▷ Never install the pump set with the motor terminal box pointing downwards. ▷ Undo the hexagon socket head cap screws. Then turn the motor housing.
	CAUTION
	<p>Air entering the pump Damage to vertically installed pump sets whose direction of flow is downwards!</p> <ul style="list-style-type: none"> ▷ Fit a vent valve at the highest point of the suction line.
	NOTE
	<p>We recommend installing shut-off valves upstream and downstream of the pump. Make sure that no leaking water can drip into the pump motor or terminal box.</p>
	NOTE
	<p>The direction of flow of a vertically installed pump should be upwards.</p>

	NOTE
	Do not install the pump at the lowest point of the system to prevent any impurities from collecting in the pump.

The control unit can be turned. The position must be effected with the pump set removed from the system.

1. Undo and store the 4 hexagon socket head cap screws.
2. Rotate the drive unit until it has reached the required position. Compare it against the permissible installation positions. Adjust the position if required.
3. Fit and tighten the 4 hexagon socket head cap screws again.

Permissible installation positions

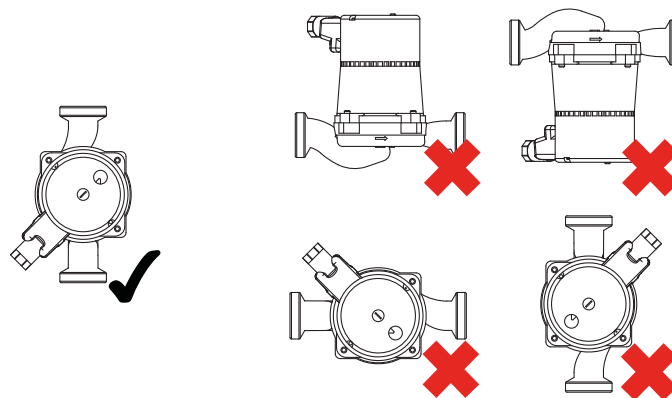



Fig. 3: Permissible installation positions

	! DANGER
	Leakage at the pump Leakage of hot fluids! ▷ Insert the O-ring in the correct position.

Screw-ended pumps

1. Position the pump set as indicated in an easily accessible place.
 ⇒ An arrow on the pump casing and thermal insulation shell indicates the direction of flow.
2. Accurately insert the sealing element.
3. Connect the pump and piping with a pipe union.
4. Tighten the pipe union hand-tight with an assembly tool (e.g. pipe wrench).
5. Accurately insert the sealing element in the opposite pipe union.
6. Tighten the pipe union hand-tight with an assembly tool (e.g. pipe wrench).

5.4 Connecting the piping

	! WARNING
	Hot surface Risk of burns ▷ Never touch a pump set when it is in operation.

	⚠ WARNING
	<p>Impermissible loads acting on the pump nozzles Risk of burns by hot fluids escaping!</p> <ul style="list-style-type: none"> ▷ Do not use the pump as an anchorage point for the piping. ▷ Anchor the pipes in close proximity to the pump and connect them without transmitting any stresses or strains. ▷ Take appropriate measures to compensate for thermal expansion of the piping.

	CAUTION
	<p>Contamination/dirt in the piping Damage to the pump!</p> <ul style="list-style-type: none"> ▷ Flush the piping prior to commissioning or replacing the pump. Remove any foreign matter.

	NOTE
	<p>Installing check and shut-off elements in the system is recommended, depending on the type of plant and pump. However, such elements must not obstruct proper drainage or hinder disassembly of the pump.</p>

- ✓ Suction lift lines have been laid with a rising slope, suction head lines with a downward slope towards the pump.
 - ✓ The nominal diameters of the pipelines are equal to or greater than the nominal diameters of the pump nozzles.
 - ✓ The pipelines have been anchored in close proximity to the pump and connected without transmitting any stresses or strains.
1. Thoroughly clean, flush and blow through all vessels, pipelines and connections (especially of new installations).







	CAUTION
	<p>Welding beads, scale and other impurities in the piping Damage to the pump!</p> <ul style="list-style-type: none"> ▷ Free the piping from any impurities.

5.5 Casing/insulation

	⚠ WARNING
	<p>The pump takes on same temperature as the fluid handled Risk of burns!</p> <ul style="list-style-type: none"> ▷ Insulate the volute casing. ▷ Fit protective equipment.

	CAUTION
	<p>Heat building up at motor housing and pump casing Pump overheating!</p> <ul style="list-style-type: none"> ▷ Never insulate the motor and electronic system housings.

5.6 Electrical connection

	 DANGER
	<p>Electrical connection work by unqualified personnel Risk of fatal injury due to electric shock!</p> <ul style="list-style-type: none"> ▷ Always have the electrical connections installed by a trained and qualified electrician. ▷ Observe regulations IEC 60364 and, for explosion-proof models, EN 60079.
	 DANGER
	<p>Work performed on an energised terminal box Danger of death from electric shock!</p> <ul style="list-style-type: none"> ▷ Switch off the power supply at least 5 minutes prior to commencing work and ensure that it cannot be switched on again unintentionally.
	 WARNING
	<p>Incorrect connection to the mains Damage to the mains network, short circuit!</p> <ul style="list-style-type: none"> ▷ Observe the technical specifications of the local energy supply companies.

1. Check the available mains voltage against the data on the name plate.

The pumps must be connected in accordance with the applicable regulations. The electrical data is printed on the name plate of the pump.

The pumps do not require any external motor protection.

	NOTE
	<p>If a conventional motor protection switch is used, the overload setting must be adjusted to the current indicated on the name plate of the pump. When changing the speed level, this setting must be adjusted accordingly.</p>

If the piping is not filled with water, the pump should only be operated for a short period of time to prevent any damage to the pump bearings (lubricated by the fluid pumped).

1. Check the available mains voltage against the data on the name plate.
2. Loosen the two screws at the front cover using a suitable screwdriver.
3. Remove the front cover.
4. Lead a suitable three-phase power cable (e.g. 3 x 0.75 mm²) through the pump's cable gland.
5. Strip the cable sheath and cores in accordance with the applicable regulations.
6. Connect the cores to the pump's terminals L, N and PE.

7. Firmly tighten the cable gland and provide strain relief.
8. Place the front cover in position and close tightly using the two screws.

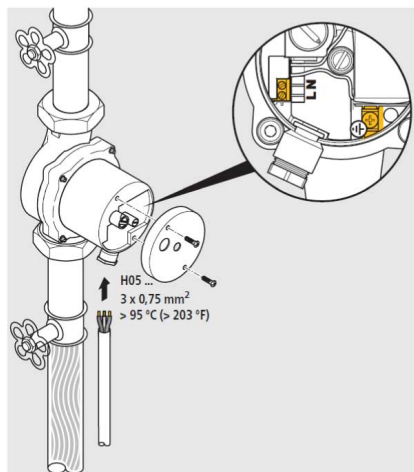

9. The power cable should be led downwards in a suitable fashion in order to prevent damage.

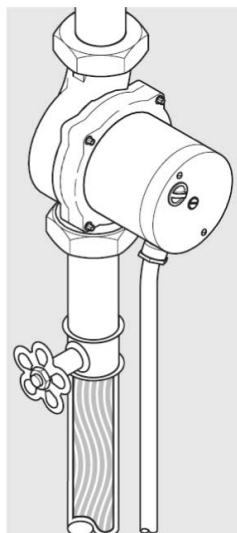

6 Commissioning/Start-up/Shutdown





6.1 Commissioning/Start-up

6.1.1 Prerequisites for commissioning/start-up

Before commissioning/starting up the pump set, make sure that the following conditions are met:

- The pump set has been properly connected to the power supply and is equipped with all protection devices.
- The pump has been primed with the fluid to be handled. The pump has been vented.
- After prolonged standstill of the pump (set) the pump rotor has been rotated by means of a screwdriver to make sure the motor is not locked.

6.1.2 Safety regulations

	! DANGER
	Hazardous fluids / substances in the piping Risk of injury! ▶ Flush and thermally disinfect the piping prior to commissioning the pump.
	! DANGER
	Pump operation without front cover Risk of fatal injury due to electric shock! Risk of injury! ▶ Only operate the pump with the front cover fitted and with the PE connection (earthing) established.
	! WARNING
	Hot surface Risk of injury! ▶ Allow the pump set to cool down to ambient temperature.
	! WARNING
	Risk of hot fluid escaping as a result of incorrect assembly/ dismantling Risk of burns! ▶ Do not damage the seal elements and sealing surfaces.

6.1.3 Priming and venting the pump

	CAUTION
	Increased wear due to dry running Damage to the pump set! ▶ Never operate the pump set without liquid fill. ▶ Never close the shut-off element in the suction line and/or supply line during pump operation.

1. Vent the pump and suction line and prime both with the fluid to be handled.
2. Fully open the shut-off element in the suction line.

3. During operation (at top speed) loosen the screw plug until some air escapes.

	DANGER
	<p>Hot fluid handled spurting out in the vent plug area Risk of burns! ▷ Wear protective clothing.</p>

4. Close the screw plug again.

5. Repeat this procedure several times until all air has escaped.

6.1.4 Start-up

	DANGER
	<p>Non-compliance with the permissible pressure and temperature limits if the pump is operated with the suction and discharge lines closed. Hot fluids escaping! ▷ Never operate the pump with the shut-off elements in the suction line and/or discharge line closed. ▷ Only start up the pump set against a slightly or completely open discharge-side shut-off element.</p>

	DANGER
	<p>Excessive temperatures due to insufficient lubrication of the plain bearings Damage to the pump set! ▷ Never operate the pump set without liquid fill. ▷ Prime the pump as per operating instructions. ▷ Always operate the pump within the permissible operating range.</p>

	WARNING
	<p>Hot surfaces - Pump and piping take on the temperature of the fluid handled. Risk of burns! ▷ Do not touch hot surfaces.</p>

	CAUTION
	<p>Abnormal noises, vibrations, temperatures or leakage Damage to the pump! ▷ Switch off the pump (set) immediately. ▷ Eliminate the causes before returning the pump set to service.</p>

- ✓ The system piping has been cleaned.
- ✓ Pump, suction line and inlet tank (if fitted) have been vented and primed with the fluid to be handled.
- ✓ The priming lines and venting lines have been closed.
 1. Fully open the shut-off element in the suction head line/suction lift line.
 2. Close or slightly open the shut-off element in the discharge line.
 3. Start up the motor.

6.1.5 Mode of operation

6.1.5.1 Open-loop control mode with manual setpoint input

The pump is operated at the set speed level (characteristic curve). The required speed level is selected by turning the control knob at the control module. In this example (see illustration) the pump is operated at medium speed (speed level 2). The speed level should be set for trouble-free operation of the system, minimising running noises and energy consumption.

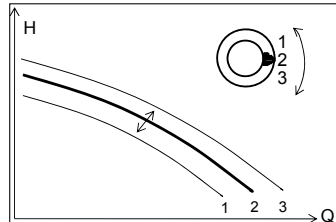

Fig. 4: Open-loop Control settings

6.2 Shutdown

- ✓ The shut-off element in the suction line is and remains open.
 1. Close the shut-off element in the discharge line.
 2. Switch off the motor and make sure the pump set runs down smoothly to a standstill.

	NOTE
	If the discharge line is equipped with a non-return or check valve, the shut-off element may remain open provided that the system conditions and system regulations are considered and observed.

For prolonged shutdown periods:

1. Close the shut-off element in the suction line.

	CAUTION
	<p>Risk of freezing during prolonged pump shutdown periods Damage to the pump!</p> <ul style="list-style-type: none"> ▷ Drain the pump and the cooling/heating chambers (if any) or otherwise protect them against freezing.

6.3 Operating limits

	⚠ DANGER
	<p>Non-compliance with operating limits for pressure, temperature, fluid handled and speed Hot fluids escaping!</p> <ul style="list-style-type: none"> ▷ Comply with the operating data indicated in the data sheet. ▷ Avoid prolonged operation against a closed shut-off element. ▷ Never operate the pump at product temperatures exceeding those specified in the data sheet or on the name plate.

6.3.1 Ambient temperature

	CAUTION
	<p>Operation outside the permissible ambient temperature Damage to the pump (set)!</p> <ul style="list-style-type: none"> ▷ Observe the specified limits for permissible ambient temperatures.

Observe the following parameters and values during operation:

Table 6: Fluid temperature specified for the ambient temperature [°C]

	Fluid temperature	Ambient temperature
All	90	30
	70	40

6.3.2 Density of the fluid handled

The pump input power changes in proportion to the density of the fluid handled.

	CAUTION
	<p>Impermissibly high density of the fluid handled Motor overload!</p> <ul style="list-style-type: none"> ▷ Observe the information on fluid density in the data sheet.

6.4 Shutdown/storage/preservation

6.4.1 Measures to be taken for shutdown

The pump (set) remains installed

- ✓ Sufficient fluid is supplied for the operation check run of the pump.
 1. For prolonged shutdown periods, start up the pump (set) regularly between once a month and once every three months for approximately five minutes.
 - ⇒ This will prevent the formation of deposits within the pump and the pump intake area.

The pump (set) is removed from the pipe and stored

- ✓ The pump has been drained properly (⇒ Section 7.2, Page 24) and the safety instructions for dismantling the pump have been observed.
 1. Observe any additional instructions and information provided. (⇒ Section 3, Page 10)

6.5 Returning to service

	⚠ WARNING
	<p>Failure to re-install or re-activate protective devices Risk of injuries by escaping fluid!</p> <ul style="list-style-type: none"> ▷ As soon as the work is completed, re-install and/or re-activate any safety-relevant and protective devices.

- ✓ The safety-relevant devices and protective devices have been properly re-installed and re-activated.
 1. For returning the equipment to service, observe the sections on commissioning/start-up (⇒ Section 6.1, Page 20) and the operating limits .
 2. In addition, carry out all servicing/maintenance operations before returning the pump (set) to service (⇒ Section 7, Page 24) .

7 Servicing/Maintenance

7.1 Servicing/inspection

The circulator pumps are almost maintenance-free.

If the pump has not been in operation for a prolonged period of time or if the system is severely contaminated, the rotor can become blocked.

The rotor can be deblocked by undoing the screw plug, inserting a screw driver into the shaft end, and rotating the rotor.

	NOTE
	<p>Any repairs on the pump must only be performed by one of our authorised service partners. In the event of a failure, please contact your heating system engineer.</p>

7.2 Drainage/cleaning

	⚠ WARNING
	<p>Fluids handled, consumables and supplies which are hot and/or pose a health hazard Hazard to persons and the environment!</p> <ul style="list-style-type: none"> ▷ Collect and properly dispose of flushing fluid and any fluid residues. ▷ Wear safety clothing and a protective mask if required. ▷ Observe all legal regulations on the disposal of fluids posing a health hazard.

1. Always flush and clean the pump before transporting it to the workshop.
Provide a certificate of decontamination for the pump.



7.3 Removing the pump set from the piping

7.3.1 Safety regulations



	⚠ DANGER
	<p>Hazardous fluids / substances in the piping Risk of injury!</p> <ul style="list-style-type: none"> ▷ Flush and thermally disinfect the piping prior to commissioning the pump.

	⚠ DANGER
	<p>Installation in potentially explosive atmospheres Explosion hazard!</p> <ul style="list-style-type: none"> ▷ Never install the pump in potentially explosive atmospheres. ▷ Never use the pump to handle explosive fluids.

	⚠ DANGER
	<p>Pump operation without front cover Risk of fatal injury due to electric shock! Risk of injury!</p> <ul style="list-style-type: none"> ▷ Only operate the pump with the front cover fitted and with the PE connection (earthing) established.



	<p style="background-color: #f4a460; padding: 2px;">⚠ WARNING</p> <p>Hot surface Risk of injury!</p> <ul style="list-style-type: none"> ▷ Allow the pump set to cool down to ambient temperature.
	<p style="background-color: #f4a460; padding: 2px;">⚠ WARNING</p> <p>Risk of hot fluid escaping as a result of incorrect assembly/ dismantling Risk of burns!</p> <ul style="list-style-type: none"> ▷ Do not damage the seal elements and sealing surfaces.

7.3.2 Removing the complete pump set from the piping

	<p style="background-color: #d9534f; padding: 2px;">⚠ DANGER</p> <p>Work performed on an energised terminal box Danger of death from electric shock!</p> <ul style="list-style-type: none"> ▷ Switch off the power supply at least 5 minutes prior to commencing work and ensure that it cannot be switched on again unintentionally.
	<p style="background-color: #d9534f; padding: 2px;">⚠ DANGER</p> <p>Pump acting as a generator when running in reverse Danger to life from hazardous induction voltage at the motor terminals!</p> <ul style="list-style-type: none"> ▷ Prevent the fluid from flowing back by closing the shut-off elements.

- ✓ The relevant notes and steps have been observed/carried out.
 - ✓ The pump has cooled down to ambient temperature.
 - ✓ A container for collecting the fluid has been positioned underneath the pump set.
1. De-energise the pump set (disconnect the motor) and ensure that it cannot be re-energised unintentionally.
 2. Close the shut-off elements.
 3. Disconnect the discharge and suction nozzles from the piping.
 4. Depending on the pump/motor size, remove the supports from the pump set.
 5. Remove the complete pump set from the piping.

8 Trouble-shooting

	 WARNING
	<p>Improper work to remedy faults Risk of injury!</p> <p>▷ For any work performed to remedy faults, observe the relevant information given in this operating manual and/or in the product literature provided by the accessories manufacturer.</p>

If problems occur that are not described in the following table, consultation with the KSB customer service is required.

- A Pump is running, but does not deliver
- B Pump does not start up or pump running irregularly
- C Pump running but not delivering water.
- D Noises during pump operation

Table 7: Trouble-shooting

A	B	C	D	Possible cause	Remedy ¹⁾
X	-	-	-	Pump not connected to power supply	Check the fuses and correct connection to power supply. If required, disconnect the pump from the power supply and re-connect it to the power supply (voltage reset).
-	X	-	-	Impurities in the pump	See section on maintenance. (⇒ Section 7.1, Page 24)
-	-	X	-	Air in the system	Vent the system and the pump.
-	-	X	-	Shut-off valves closed	Open the gate valve.
-	-	-	X	Pump power output too high	Select a lower speed level.
-	-	-	X	System pressure too low	Increase the system pressure by filling more water into the boiler.
-	-	-	X	Air in the system	Vent the pump (vent plug) and piping.

1) Pump pressure must be released before attempting to remedy faults on parts which are subjected to pressure.

9 Related Documents

9.1 Wiring diagram

1-phase

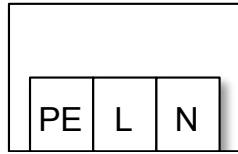

Fig. 5: Wiring diagram for single-phase alternating current

10 EU Declaration of Conformity

Manufacturer:

KSB SE & Co. KGaA
Johann-Klein-Straße 9
67227 Frankenthal (Germany)

The manufacturer herewith declares that the product:

Calio-Therm NC

Serial number range: 1801 to 1952

- is in conformity with the provisions of the following Directives as amended from time to time:
 - Electromagnetic Compatibility Directive 2014/30/EU
 - Low-voltage Directive 2014/35/EU

The manufacturer also declares that

- the following harmonised international standards have been applied:
 - DIN EN 55014-1, EN 55014-2
 - DIN EN 60335-1, EN 60335-2-51
 - DIN EN 61000-3-2, EN 61000-3-3

The EU Declaration of Conformity was issued in/on:

Frankenthal, 1 February 2018

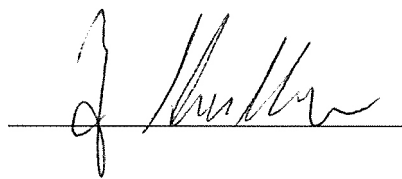

Joachim Schullerer
Head of Product Development Pump Systems and Drives
KSB SE & Co. KGaA
Johann-Klein-Straße 9
67227 Frankenthal

Index

A

Automatic functions 13

B

Bearings 13

C

Commissioning 20

Connections 13

D

Design 13

Designation 12

Disposal 11

Drive 13

E

Event of damage 6

F

Fields of application 7

Fluid handled
Density 23

I

Intended use 7

K

Key to safety symbols/markings 7

M

Manual functions 13

N

Name plate 12

O

Operating limits 22

Operating modes 13

P

Piping 17

Preservation 10, 23

Product description 12

R

Return to supplier 10

Returning to service 23

S

Safety 7

Safety awareness 8

Shutdown 23

Signalling and display functions 13

Start-up 21

Storage 10, 23

T

Trouble-shooting

Causes and remedies 26

W

Warnings 7

Warranty claims 6



KSB SE & Co. KGaA

Johann-Klein-Straße 9 • 67227 Frankenthal (Germany)

Tel. +49 6233 86-0

www.ksb.com