

026

Godkänd enligt EN215 tillsammans med/ Approved under EN215 in combination with/ Geprüft nach EN215 in kombination mit/ Approuvé selon EN215 avec/ Godkendt iht. EN215 sammen med FVR10, FVV10, FVAV10, FVR15, FVV15, FVAV 15.
 Hyväksytty EN215 mukaan FVR10, FVV10, FVAV10, FVR15, FVV15, FVAV15 kanssa.

1.

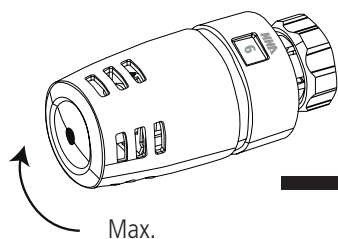

Begränsning °C
 Limit °C
 Begrenzung °C
 Limite de température °C
 rajoitus °C
 Begrænsning °C
 begrensnng °C

sid.2.
 page 2.
 S. 2.
 p. 2.
 sivu 2
 side 2
 side 2

2.

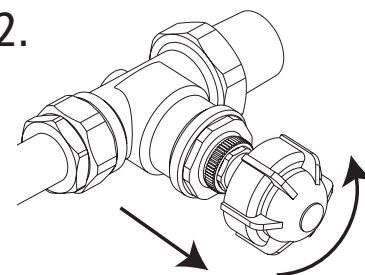

3.

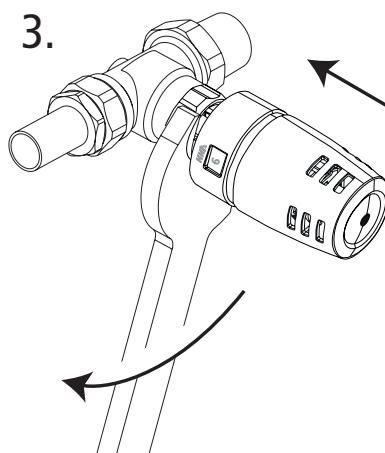

Fönster synligt !!
 Window visible!!
 Das Fenster muss sichtbar sein!
 Fenêtre visible !!
 Ikkuna näkyvissä!
 Vindue synligt!
 Vindu synlig!

4.

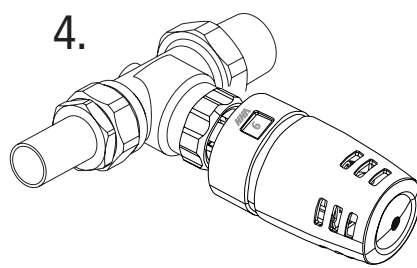

Ställ in önskad temperatur.
 Set the required temperature.
 Stellen Sie die gewünschte Temperatur ein.
 Réglez la température souhaitée.
 Aseta haluttu lämpötila.
 Indstil ønsket temperatur.
 Still inn ønsket temperatur.

0	*	1	3	5	6	7	8	9
Stängd	10	12	16	20	22	24	26	28 °C
Closed	8	10	14	18	20	22	24	26 °C
Geschlossen								
Fermée								
Kiinni								
Lukket								

Temp. vid stängd ventil
 Temp. when valve is fully closed
 Temp. bei geschl. Ventil
 Temp. à vanne fermée.
 Lämpötila, kun venttiiliön kiinni.
 Temp. ved lukket ventil
 Ca rumtemp. / room temp. / Raumtemp.
 température de la pièce / Huonelämpötila
 Ca. rumtemp. (2K)

Max °C

Min °C

