

Data sheet

Standard JIP™ ball valves (PN 16, 25, 40)

Description



Danfoss Standard JIP™ ball valves is a range of reduced bore shut off valves developed for District Heating and District Cooling networks, with circulating medium.

It is a range of steel ball valves with fully welded body.

The valve design makes them ideal for building installation due to:

- Energy saving: with optimum flow design valves have highest kv on the market and consequently lowest pump energy costs.
- Long lifetime and optimal tightness due to design and material selection in ball seal and stem seal (carbon reinforced PTFE) ;
- The valves are maintenance free, besides the shut off valves in the core distribution network Danfoss offers a range of supplementary valves, e.g. hot tap valves, branching valves, twin valves and draining valves.

Main data:

- DN 15-600
- $k_{vs} = 11-26.300 \text{ m}^3/\text{h}$
- PN 16 / 25 / 40
- Temperature: 0 ... 180 °C
- Medium: Circulation water / glycolic water up to 50 %
- Min. storage and transport temperature: -40 °C

Approvals and norms:

- 100 % final inspection. Leak and shell test as well as dimension and functionality test is performed on each and every valve according to applicable standard (EN 12266 part 1 P10-P11-P12 & part 2 F20).
- PED Directive 97/23/EEC Modul H1
- Danfoss A/S is certified according to ISO 9001
- Furthermore certified according to ISO 14001 and OHSAS 18001.

Ordering
JIP-WW welding
JIP-FF flange

Code No.						
DN [mm]	WW PN 25	WW PN 40	DN [mm]	FF PN 16	FF PN 25	FF PN 40
15	X	065N0100	15	-	X	065N0300
20		065N0105	20	-		065N0305
25		065N0110	25	-		065N0310
32		065N0115	32	-		065N0315
40		065N0120	40	-		065N0320
50		065N0125	50	-		065N0325
65	065N4280	X	65	065N4282	065N4281	X
80	065N4285		80	065N4287	065N4286	
100	065N0140		100	065N0240	065N0340	
125	065N0745		125	065N0845	065N0945	
150	065N0750		150	065N0850	065N0950	
200	065N0755		200	065N0855	065N0955	

DN [mm]	Code No. WW PN 25		Code No. FF PN 16		Code No. FF PN 25	
	Valve with worm gear	Valve with gear flange	Valve with worm gear	Valve with gear flange	Valve with worm gear	Valve with gear flange
65	065N0134	065N0132	065N0223	065N0232	065N0331	065N0332
80	065N0139	065N0137	065N0236	065N0237	065N0336	065N0337
100	065N0144	065N0142	065N0243	065N0242	065N0341	065N0342
125	065N0146	065N0147	065N0246	065N0247	065N0346	065N0347
150	065N0151	065N0152	065N0251	065N0252	065N0351	065N0352
200	065N0156	065N0157	065N0256	065N0257	065N0356	065N0357
250	065N0161	065N0162	065N0261	065N0262	065N0361	065N0362
300	065N0166	065N0167	065N0266	065N0267	065N0366	065N0367
350	065N0171	065N0172	065N0271	065N0272	065N0371	065N0372
400	065N0176	065N0177	065N0276	065N0277	065N0376	065N0377
450	065N0178	065N0179	065N0278	065N0279	065N0378	065N0379
500	065N0181	065N0182	065N0281	065N0282	065N0381	065N0382
600	065N0186	065N0187				

JIP-II internal thread
JIP-IW internal thread/welding

DN [mm]	Code No. II PN 40		DN [mm]	Code No. IW PN 40	
	L-handle high stem	T-handle low stem		L-handle high stem	T-handle low stem
15	065N0800	065N0802	15	065N0900	065N0904
20	065N0805	065N0807	20	065N0905	065N0908
25	065N0810	065N0812	25	065N0910	065N0914
32	065N0815	X	32	065N0915	X
40	065N0820		40	065N0920	
50	065N0825		50	065N0925	

Ordering

JIP-FW flange/welding

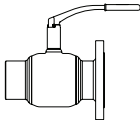

DN [mm]	Code No.		
	PN 16	PN 25	PN 40
15	See table to the right		065N0700
20			065N0705
25			065N0710
32			065N0715
40			065N0720
50			065N0725
65	065N4284	065N4283	X
80	065N4289	065N4288	
100	065N0540	065N0640	
125	065N0960	065N0975	
150	065N0965	065N0980	
200	065N0970	065N0985	

Copper valves

JIP-CC copper

JIP-IC internal thread /copper

Max temp. 130°

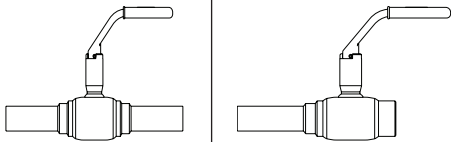

DN [mm]	Code No.	
	CC PN 16	IC PN 16
15	065N4058	065N4057
20	065N4067	065N4064
25	065N4095	065N4087

Copper twin valves for single pipe connection

JIP-IC internal thread / copper

Max temp. 130°

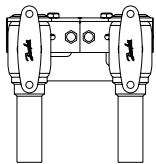

DN [mm]	Code No.
	IC PN 16 with T-handle
15	065N4195
20	065N4071

Twin valves for single pipe connection

T-handle (DN 15-25) or

L-handle (DN 32)

JIP- WW welding

JIP-II internal thread

JIP IW internal thread / welding

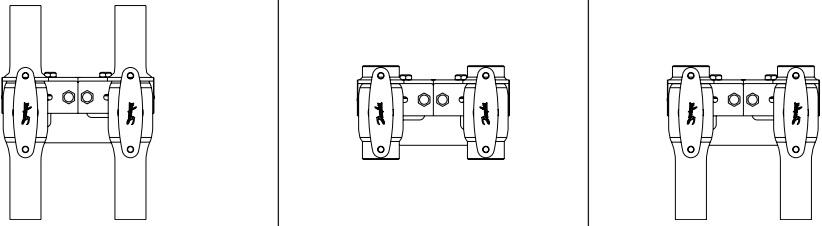

DN [mm]	Code No.		
	WW PN 40	II PN 40	IW PN 40
15	065N4001	065N0801	065N0901
20	065N4002	065N0806	065N0906
25	065N4003	065N0811	065N0911
32	065N4004	065N0816	065N0916

Data sheet
Standard JIP™ ball valves
Ordering

Twin valves for double pipe connection
T-handle
JIP-IW internal tread / welding
JIP-II internal thread

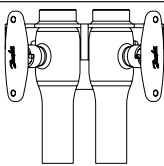
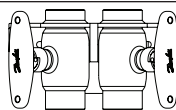
			
DN [mm]	Code No.		
	IW PN 40		II PN 40
15	065N7032		065N7022
20	065N7034		065N7024
25	065N7036		065N7026

Draining valves

JIP-WE cc welding/external thread with closing cap

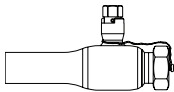
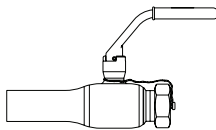
			
DN [mm]	WE PN 40-hex vers.		WE PN 40-L-handle
15	065N4322		065N4422
20	065N4323		065N4423
25	065N4324		065N4424
32	065N4325		X
40	065N4326		
50	065N4327		

Actuators

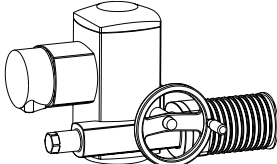
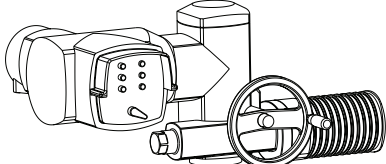
			
DN [mm]	Code No.		
	Auma NORM		Auma MATIC
65	065N8397		065N8398
80	065N8199		065N8399
100	065N8200		065N8400
125-150-200	065N8205		065N8405
250	065N8220		065N8420
300-350	065N8225		065N8425
400	065N8235		065N8435
450-500-600	065N8240		065N8440

Worm gear

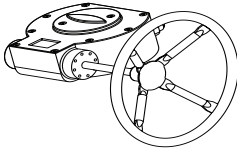
		
Description	Worm gear	Position indicator with end switch
Worm gear for DN 80-100 reduced bore	065N8100	065N8073
Worm gear for DN 125-150-200 reduced bore	065N8115	065N8074
Worm gear for DN 250 reduced bore	065N8120	065N8077
Worm gear for DN 300-350 reduced bore	065N8125	065N8082
Worm gear for DN 400 reduced bore	065N8135	065N8113
Worm gear for DN 450-500-600 reduced bore	065N8140	065N8136
End switch for end position indication IP 65 250 V ac / 5 A. 110 V ac / 5 A. 24 V dc / 3 A. Temperature range: -15 °C to +80 °C. Gear and end switches must be ordered on separate code nos. and will be mounted from factory. If there is a demand for end switches on existing ball valves, please contact your Danfoss sales representative.		

**Ordering
Accessories**

Replacement handles		
Type of handle	Fixation	Code No.
T Alu. DN 15-25	spring pin	065N8255
L Steel DN 15-32 with plastic grip	spring pin	065N8256
L Steel DN 40-50 with plastic grip	spring pin	065N8257
L Steel DN 65 with plastic grip	spring pin	065N8258
L Steel DN 80-100 with plastic grip	spring pin	065N8259
L Steel DN 125 with plastic grip	spring pin	065N8260
L Steel DN 150 with plastic grip	spring pin	065N8261
L Steel angled DN 200 with plastic grip	screw	065N8001

Marking knobs for handles DN15-100 (red/blue)	
	Code No.
Red knobs (bag with 100 pieces)	065N8303
Blue knobs (bag with 100 pieces)	065N8304

Technical data

DN [mm]	15	20	25	32	40	50	65	80	100	125	150	200	250	300	350	400	450	500	600	
K _{vs} [m ³ /h]	11	15	34	52	96	184	200	470	640	1.080	1.900	2.300	5.100	9.100	7.000	10.400	26.300	23.700	14.300	
PN	16/ 25/ 40						16/ 25													
Temp range	0-180 °C																			
Medium	Circulation water / glycolic water up to 50 %																			

Design & Material

1	Welding end	Steel P235GH
1A	Flange	Steel P245GH
2	Shell	Steel P235GH
3	Ball seal retainer	Steel P235
4	Ball	Stainless steel
5	Ball seal	Carbon reinforced PTFE
6	Stem	Stainless steel
7	Washer	Carbon reinforced PTFE
8	Stem sealing rings	Carbon reinforced PTFE
9	Compression nut	Steel
10	Packing box	Steel P235GH
11	Pin	Spring steel
12	Handle	Steel

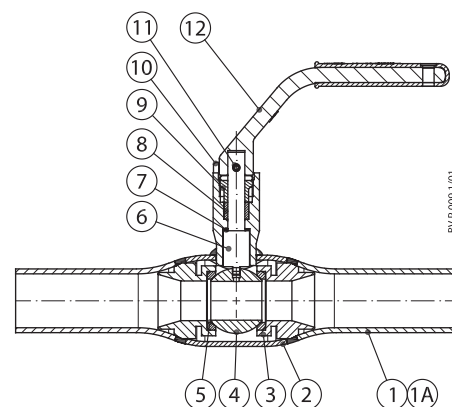

DN 15-50 with handle

Design & Material

1	Welding end	Steel P235GH
1A	Flange	Steel P245GH
2	Shell	Steel P235GH
3	Ball seal retainer	Steel P235
4	Ball	Stainless steel
5	Pipe insert	Stainless steel
6	Support ring	Stainless steel
7	Disc spring	Domex 650 MC
8	Ball seal	Carbon reinforced PTFE
9	Stem	Stainless steel
10	Washer	Carbon reinforced PTFE
11	Stem sealing rings	Carbon reinforced PTFE
12	Compression ring	Steel
13	Compression nut	Steel
14	Packing box	Steel P235GH
15	Pin	Spring steel
16	Handle	Steel

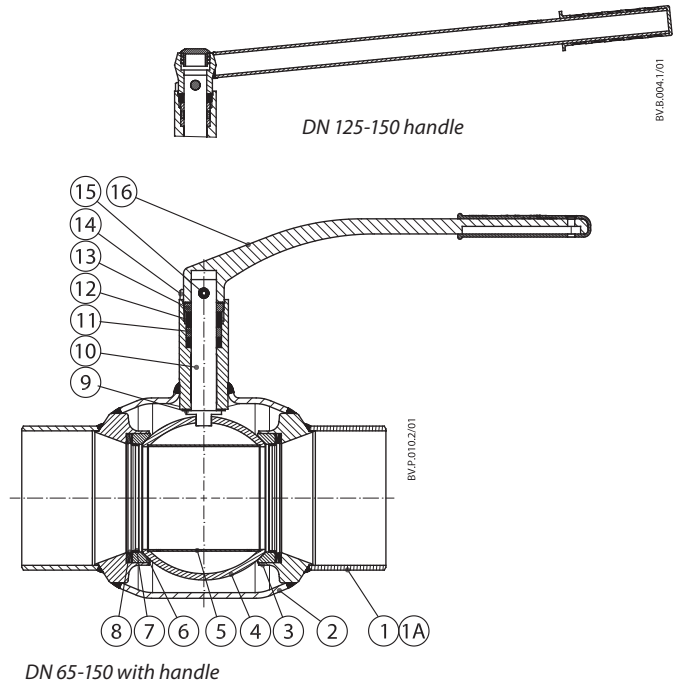

1	Welding end	Steel P235GH
1A	Flange	Steel P245GH
2	Guiding pipe	Steel P235
3	Shell	Steel P235GH
4	Ball seal retainer	Steel P235
5	Ball	Stainless steel
6	Pipe insert	Stainless steel
7	Ball seal	Carbon reinforced PTFE
8	Disc spring	Domex 650 MC
9	Stem	Stainless steel
10	Washer	Carbon reinforced PTFE
11	Packing box	Steel P245GH
12	Steam sealing rings	Carbon reinforced PTFE
13	Compression ring	Steel
14	Compression nut	Steel
15	Stopsector	Stainless steel
16	Handle	Steel

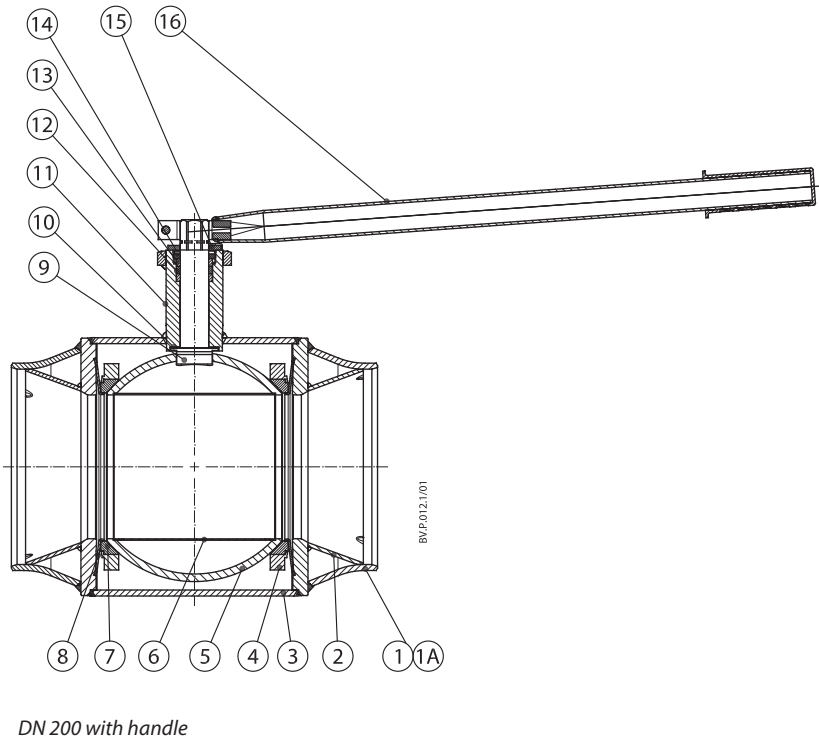

Design & Material

1	Welding end	Steel P235GH
1A	Flange	Steel P235GH
2	Guiding pipe	Steel P235GH
3	Shell	Steel P235GH
4	Ball seal retainer	Steel P235
5	Ball	Stainless steel
6	Guide pipe	Stainless steel
7	Ball seal	Carbon reinforced PTFE
8	Disc spring	Domex 650 MC
9	Stem	Stainless steel
10	Washer	Carbon reinforced PTFE
11	Packing box	Steel P245GH
12	Stem sealing rings	Carbon reinforced PTFE
13	Compression ring	Steel
14	Compression nut	Steel
15	Simmerring	Rubber
16	Key	Steel

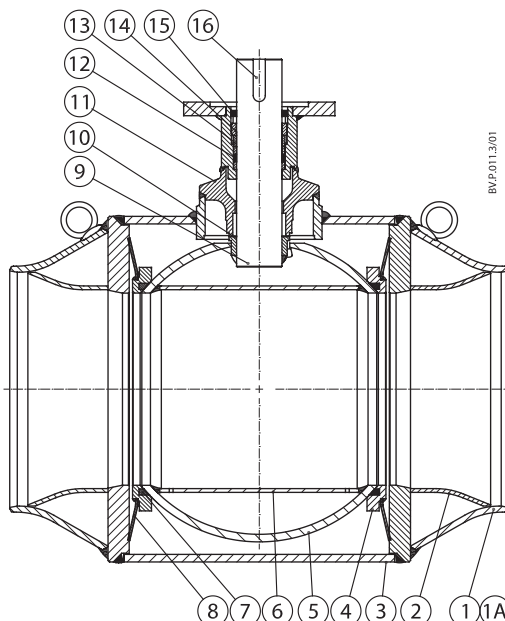

DN 65-600 with gear flange

Technical data

Pressure drop/velocity

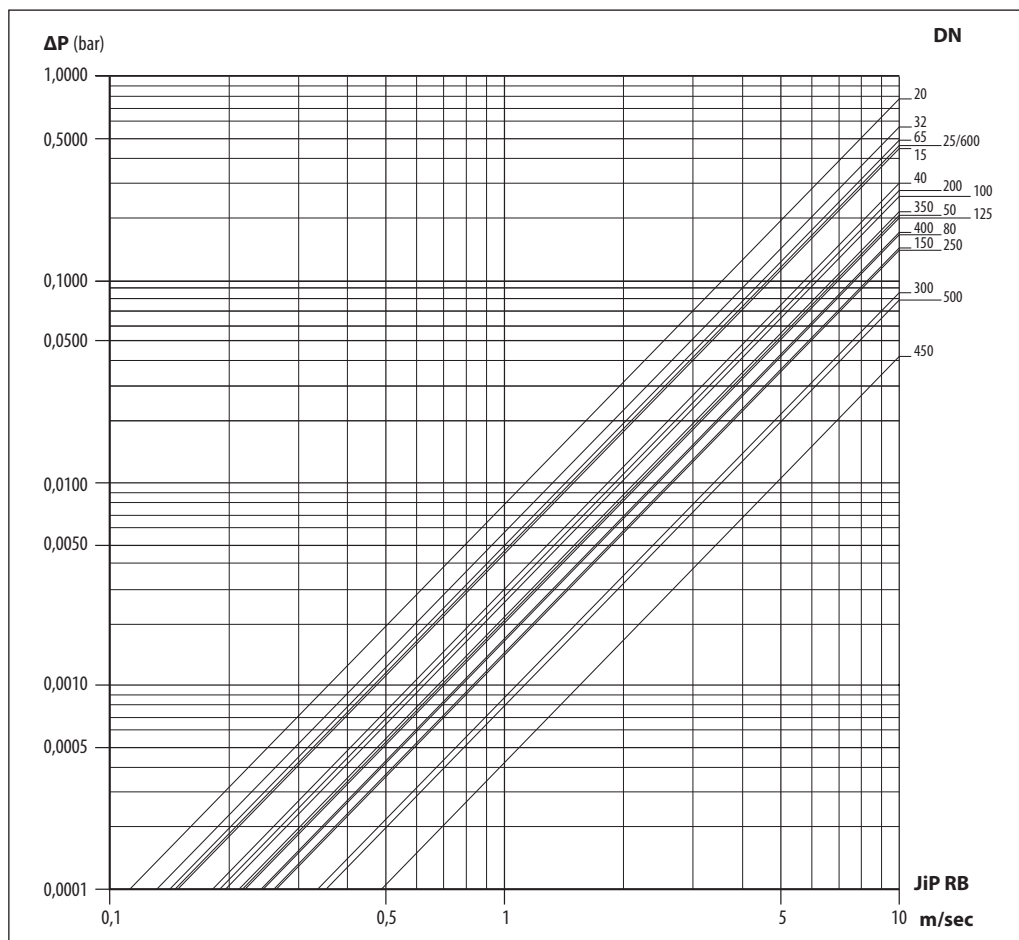

Technical data
Pressure drop/flow

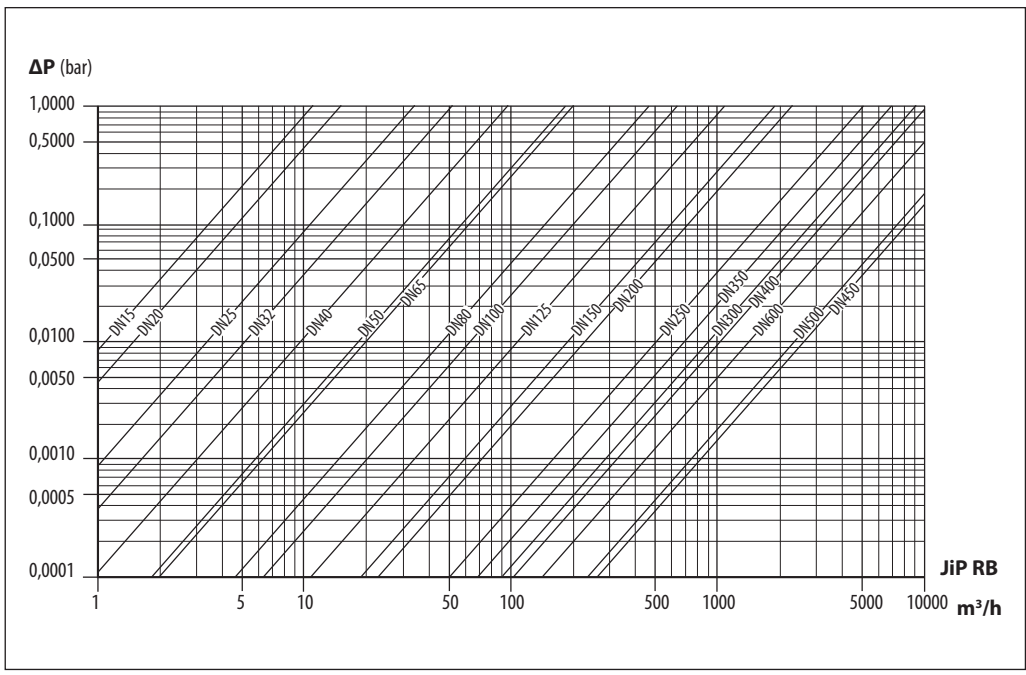

Pressure/temperature

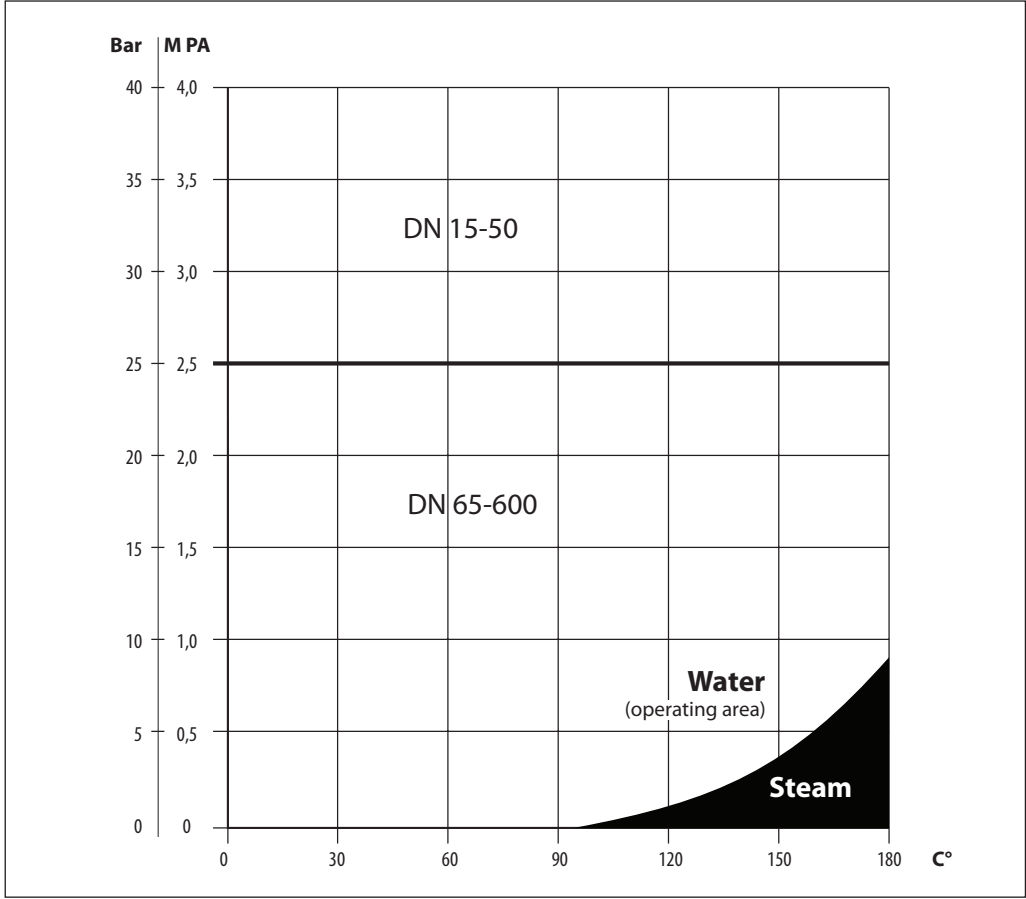

Dimensions

JIP-WW welding/
welding

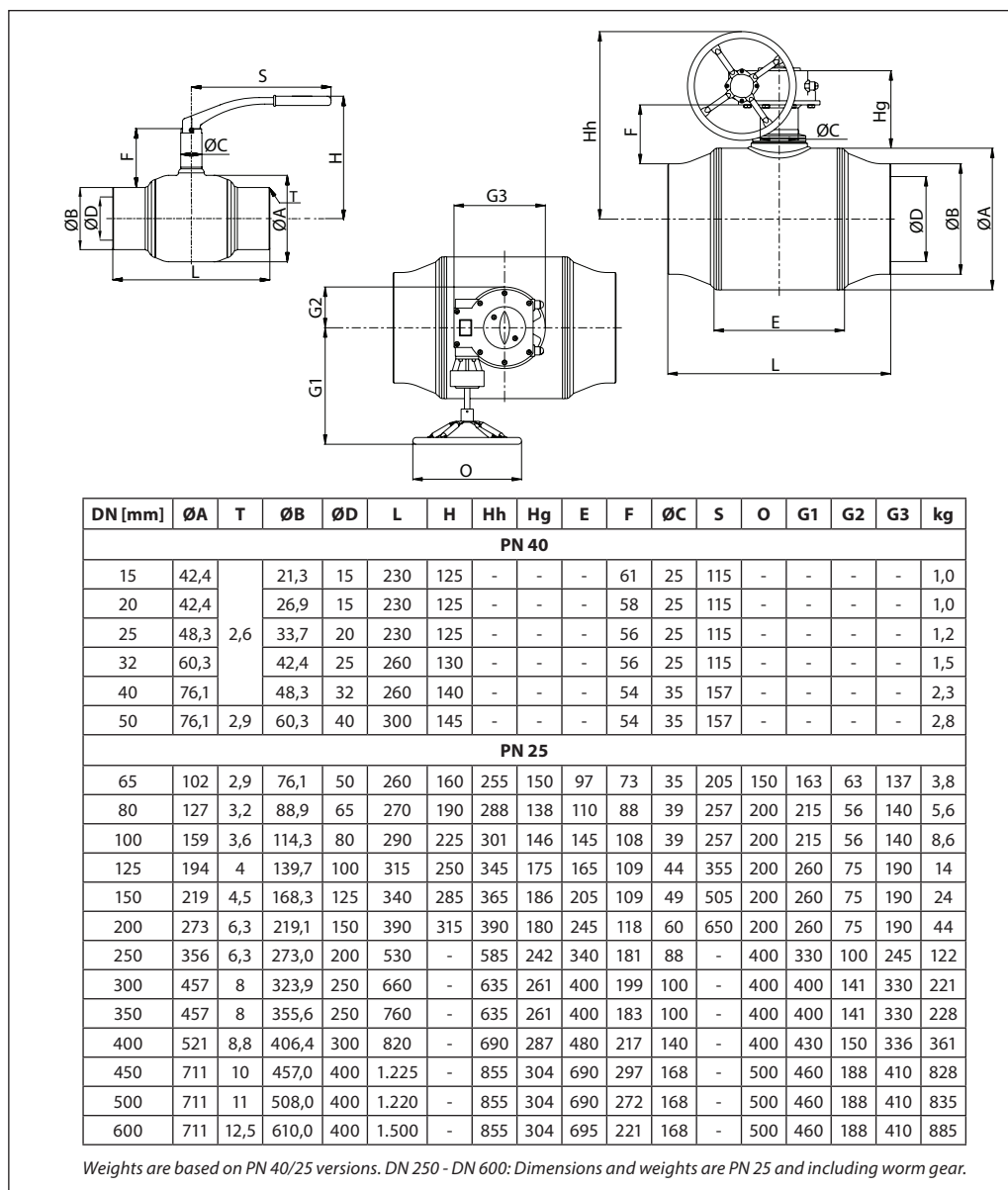

JIP-II internal thread

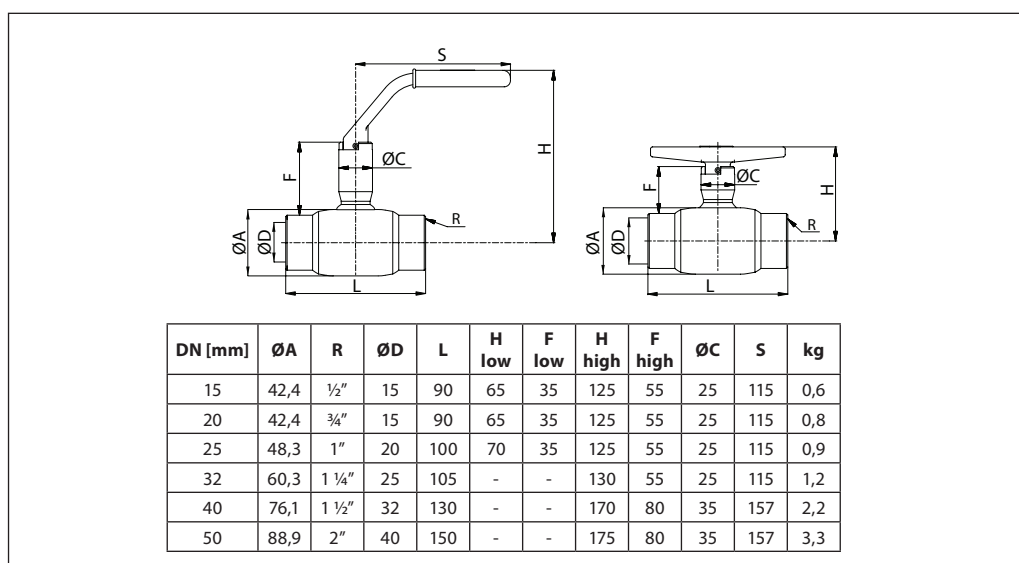

Dimensions
JIP-FF flange/flange

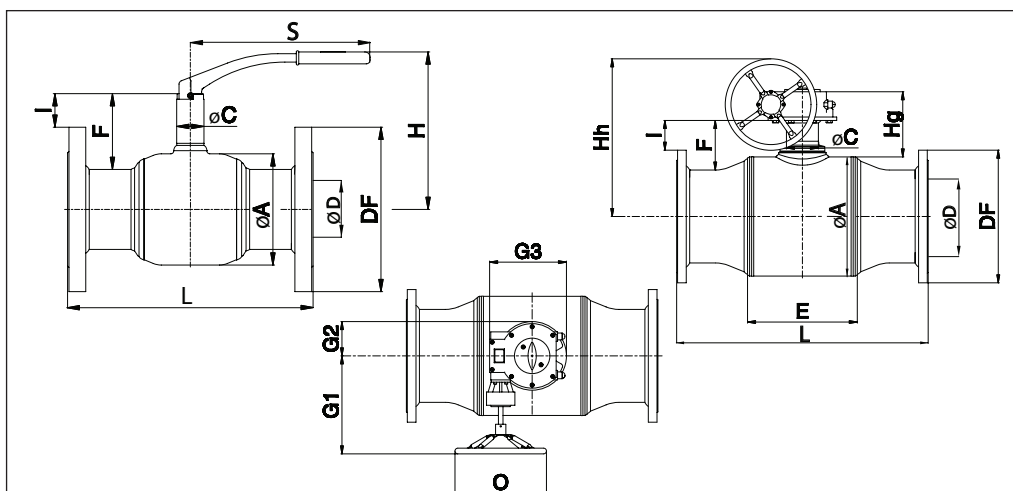

DN [mm]	ØA	ØD*	PN 16			PN 40			H	Hh	Hg	E	F	ØC	S	O	G1	G2	G3	kg	
			L	DF	I	L	DF	I													
15	42,4	15	See table PN 40 to the right			130	95	23	125	-	-	-	58	25	115	-	-	-	-	2,2	
20	42,4	15				150	105	19	125	-	-	-	58	25	115	-	-	-	-	-	2,9
25	48,3	20				160	115	15	125	-	-	-	57	25	115	-	-	-	-	-	3,5
32	60,3	25				180	140	10	130	-	-	-	59	25	115	-	-	-	-	-	4,8
40	76,1	32				200	150	35	170	-	-	-	86	35	157	-	-	-	-	-	6,5
50	76,1	40				230	165	35	175	-	-	-	86	35	157	-	-	-	-	-	8,7
			PN 16			PN 25															
65	102	50	270	185	18	290	185	18	160	255	150	100	73	35	205	150	163	63	137	10	
80	127	65	280	200	33	310	200	33	190	288	138	110	88	39	260	200	215	56	140	13	
100	159	80	300	220	56	350	235	48	225	301	146	135	108	39	260	200	215	56	140	21	
125	194	100	325	250	54	400	270	44	215	345	175	165	109	44	355	200	260	75	190	32	
150	219	125	350	285	51	480	300	43	235	365	186	205	109	49	505	200	260	75	190	46	
200	273	150	400	340	66	600	360	56	315	390	180	245	126	60	650	200	260	75	190	61	
250	356	200	650	405	115	730	425	105	-	585	242	340	181	88	-	400	330	100	245	170	
300	457	250	750	460	131	850	485	119	-	635	261	400	199	100	-	400	400	141	330	285	
350	457	250	850	520	101	980	555	84	-	635	261	400	183	100	-	400	400	141	330	322	
400	521	300	1.100	580	130	1.100	620	110	-	690	287	480	220	140	-	400	430	150	336	484	
450	711	400	1.400	640	206	1.400	670	191	-	855	304	690	297	168	-	500	460	188	410	988	
500	711	400	1.400	715	169	1.400	730	161	-	855	304	690	272	168	-	500	460	188	410	1.018	

Weights are based on PN 40/25 versions. DN 250 - DN 600: Dimensions and weights are PN 25 and including worm gear.
ØD* - internal nominal diameter

JIP-IW internal thread/welding

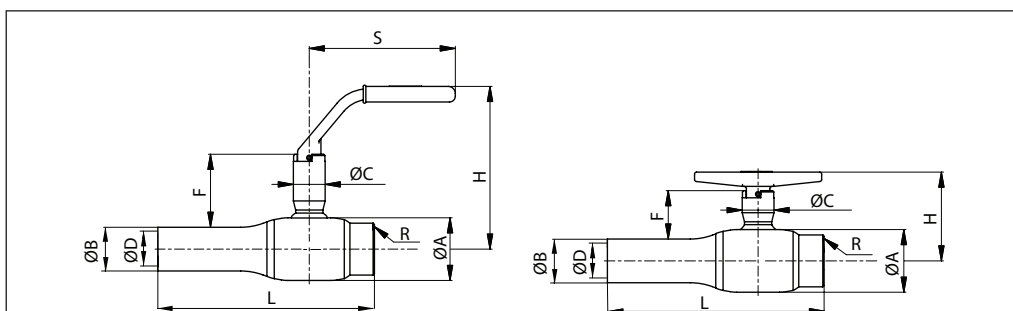

DN [mm]	ØA	ØB	R	ØD*	L	H low T	F low	H high L	F high	ØC	S	kg
15	42,4	21,3	½"	15	160	65	40	125	60	25	115	0,9
20	42,4	26,9	¾"	15	160	65	37	125	60	25	115	0,9
25	48,3	33,7	1"	20	165	70	37	125	55	25	115	1,0
32	60,3	42,4	1 ¼"	25	185	-	-	130	58	25	115	1,4
40	76,1	48,3	1 ½"	32	195	-	-	170	86	35	157	2,3
50	88,9	60,3	2"	40	225	-	-	175	86	35	157	3,3

ØD* - internal nominal diameter

Dimensions

JIP-FW flange/welding

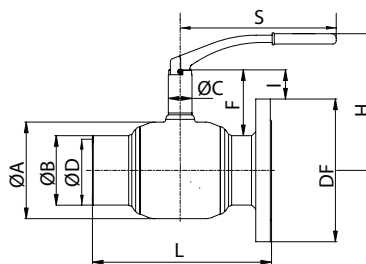

DN [mm]	ØA	ØB	ØD*	PN 16			PN 40			H	F	C	S	kg
				L	DF	I	L	DF	I					
15	42,4	21,3	15	-	-	-	180	95	23	125	58	25	115	1,7
20	42,4	26,9	15	-	-	-	190	105	19	125	58	25	115	2,0
25	48,3	33,7	20	-	-	-	195	115	15	125	57	25	115	2,4
32	60,3	42,4	25	-	-	-	220	140	10	130	59	25	115	3,4
40	76,1	48,3	32	-	-	-	230	150	35	170	86	35	157	4,3
50	88,9	60,3	40	-	-	-	265	165	35	180	86	35	157	5,9
				PN 16			PN 25							
65	102	76,1	50	265	185	18	265	185	18	160	73	35	205	7
80	127	88,9	65	275	200	33	275	200	33	190	88	39	260	9
100	159	114,3	80	295	220	56	295	235	48	225	108	39	260	15
125	194	139,7	100	320	250	54	320	270	44	250	109	44	355	23
150	219	168,3	125	345	285	51	345	300	43	285	109	49	505	35
200	273	219,1	150	395	340	66	395	360	56	315	126	60	650	65

Weights are based on PN 40/25 versions. DN 250 - DN 600: Dimensions and weights are PN 25 and including worm gear. ØD* - internal nominal diameter

Valve top and gear flange

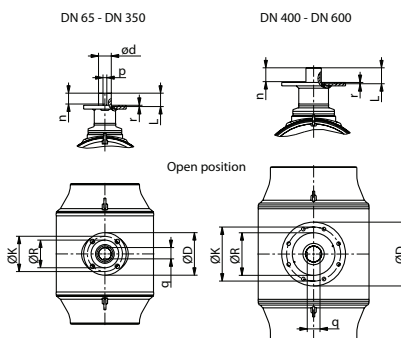

DN [mm]	Gear flange	mm					
		L	d	n	p	q	r
125	F10/F12	50	30	46	8	26	4
150		50	30				
200		50	30				
250	F16	60	50	48	14	44,5	5
300		65	60	51	18	53,2	6
350		65	60				
400	F25	75	75	60	20	60	
450		115	100	91	28	80	
500		115	100				
600		115	100				

Gear flange	No. of bolt holes	Diameter of bolt holes	D	K	R
			mm		
F10	4	11	125	102	70
F12		13	150	125	85
F16		21	210	165	130
F25	8	17	300	254	200
F30		21	350	298	230

Dimensions

House insertions

Single valve

JIP-CC copper

JIP-IC internal thread / copper

Max temp. 130°

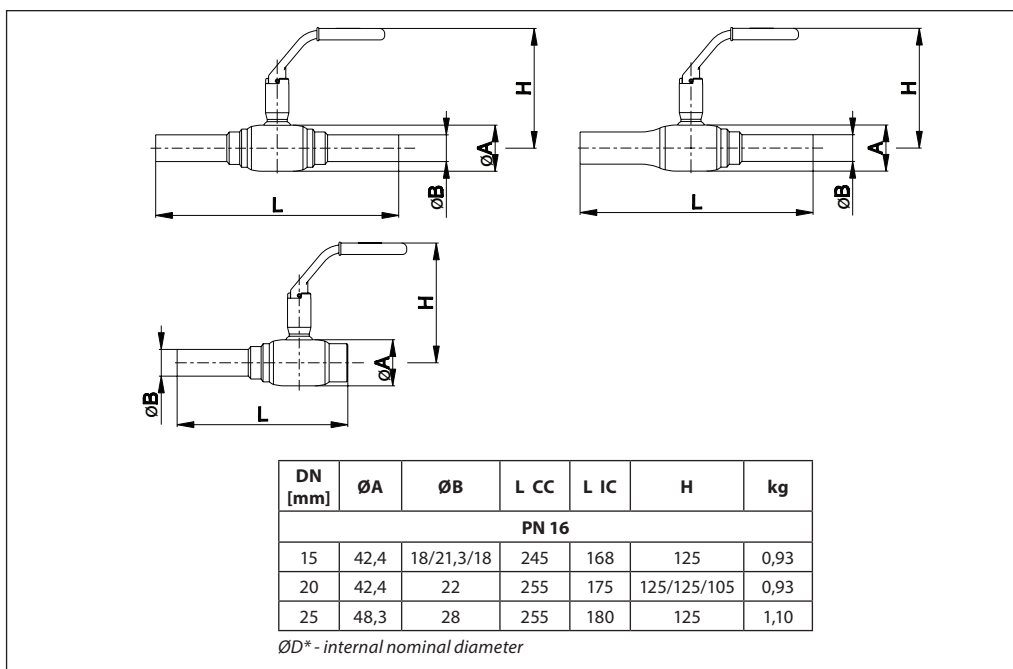

House insertions

Twin valve - single pipe

JIP-IC internal thread/copper

Max temp. 130°

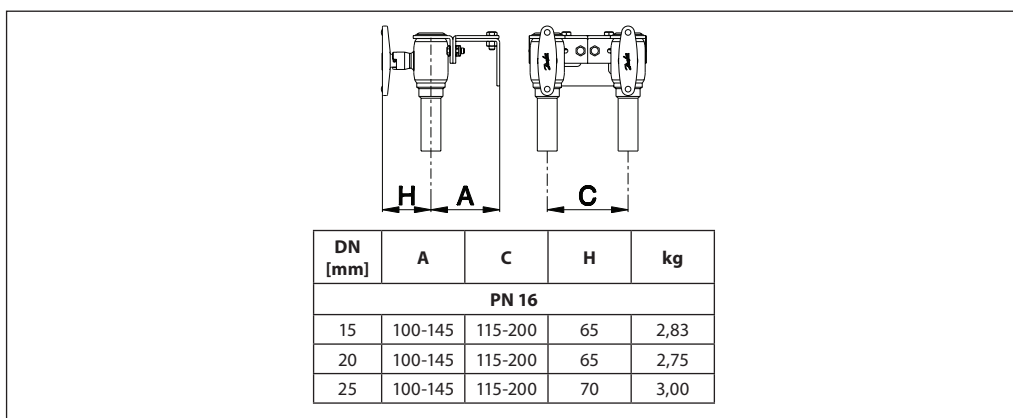

House insertions

Twin valves - single pipe

JIP-WW welding

JIP-II internal thread

JIP IW internal thread/welding

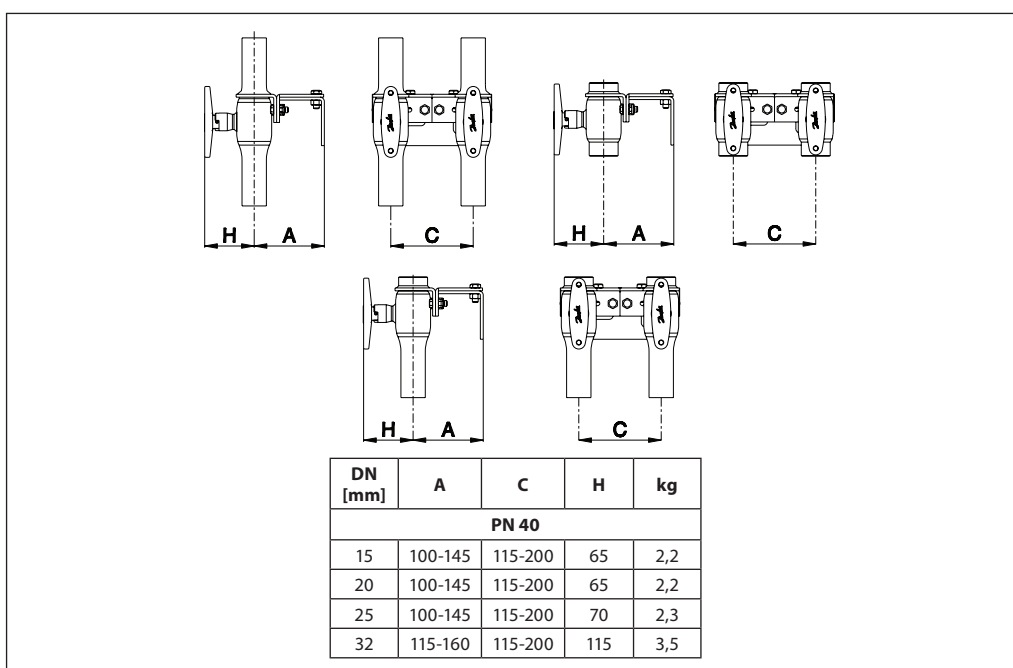

Dimensions

House insertions
Twin valves - double pipe
JIP-II/JIP-IW internal thread

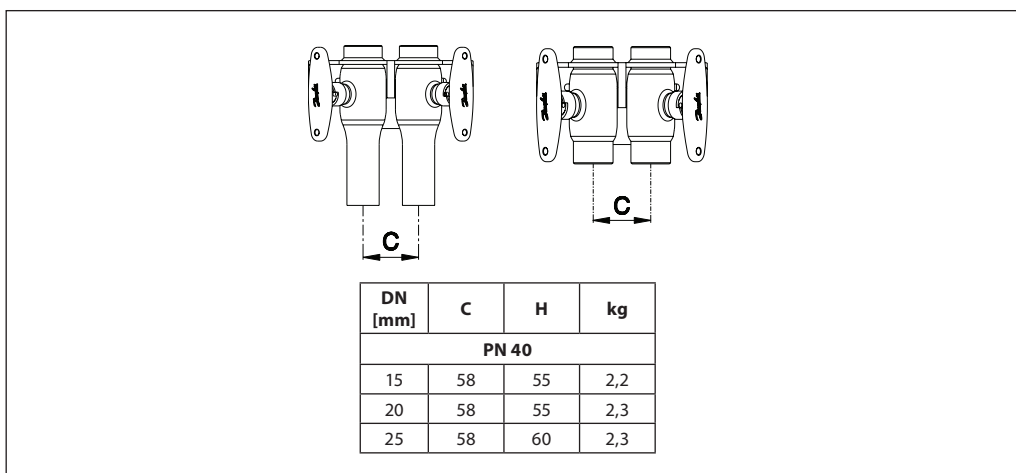

JIP-WE cc welding / external thread with closing cap

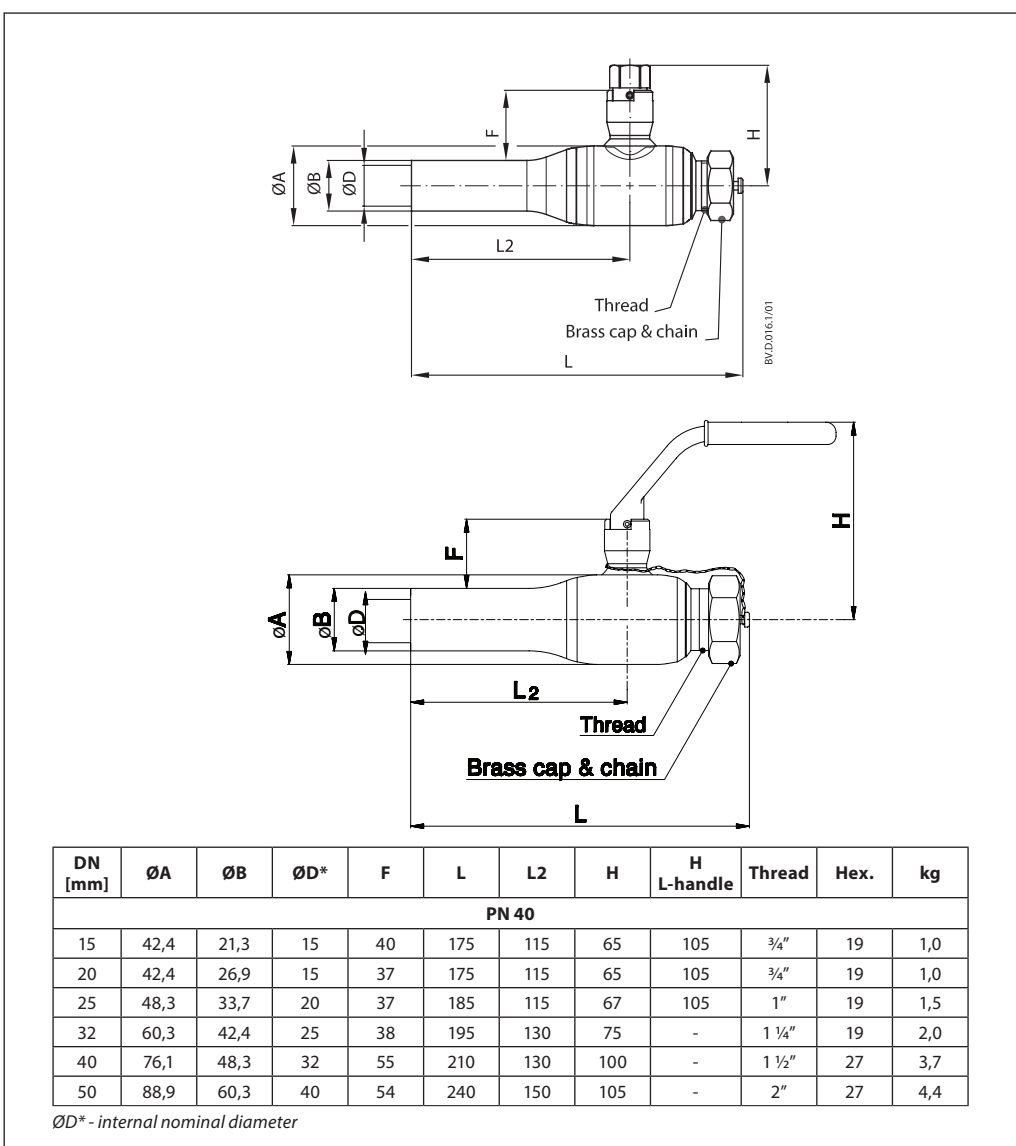

AUMA NORM electrical actuators for Danfoss ball valves

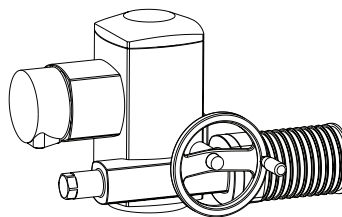

Danfoss ball valves	Auma Actuators	
DN [mm]	Type	Operating time for 90° turn [s]
65-80	SQ 05,2	16
100	SQ 07,2	32
125-150-200	SQ 10,2	32
250-350	SA 07,6+GS 100,3+VZ 4,3	142
400	SA 10,2+GS 125,3+VZ 4,3	142
450-500-600	SA 10,2+GS 160,3+GZ 160,3	207

The actuators can be equipped with various accessories.
Control and regulating unit AUMA Matic in the basis design can be supplied.
For other mains voltages than 3 × 400V/50Hz or additional questions please contact us.

When commissioning and under certain problematic system conditions, it can be necessary to choose slower actuators to avoid water hammering and oscillations.

Features:

- 2 limit switches – opening/closing
- 2 torque switches - opening/closing
- Heater
- Blinker switch for operating phase
- Manual operation with hand wheel
- Thermo switch

Main Data:

- Nominal voltage: 3 × 400 VAC, 50Hz
- Grade of enclosure: IP 68
- Wiring diagram: TPA 00R1AA-000

