

Data sheet

JIP™ hot tap ball valves

Description

**Application:**

Danfoss JIP™ hot tap ball valves are designed for extensions of district heating systems and other closed loop water systems, where the water is treated to avoid internal corrosion.

With Danfoss JIP™ hot tap ball valves new connections and maintenance of the district heating network can be done while the system is fully operational. This saves time and eliminates interruptions for the users.

Having a fully welded body, the valves meet the requirements for valves used in district heating and district cooling systems and offer the highest degree of security.

Features:

- External stem hexagon on all dimensions
- Position indicator of the ball on the stem
- 90 degree end stop
- New plug construction
- The valves are maintenance free

Main data:

- DN 15-100 mm
- k_v 11-2.300 m³/h
- PN 25/40 bar
- Temperature: 0 ... 180°C
- Medium: Circulation water / glycolic water up to 50%
- Min. storage and transport temperature: -40°C

Approvals and norms:

- 100% final inspection. Leak and shell tests as well as dimension and functionality tests are performed on each and every valve according to applicable standard (EN 12266 part 1 P10-P11-P12 & part 2 F20).
- PED 2014/68/EU module H1
- Danfoss A/S is certified according to ISO 9001, ISO 14001 and OHSAS 18001
- Hot tapping machine are TUV. A.366 – 16 approved.

Ordering

Hot tap JIP-WW and tool boxes
T = 0 ... 180 °C

Picture	DN (mm)	Hole saw diameter (mm)	PN (bar)	Code No.	Hot tapping machine (DN 15-100 mm)	Adapter Box	
	15/20	Ø 15	40	065N0050		065N1003	065N1002
	25	Ø 24		065N0051			
	32	Ø 24		065N0052			
	40	Ø 40		065N0053			
	50	Ø 40		065N0054			
	65	Ø 48	25	065N0055		065N1004	
	80	Ø 65	065N0056				
	100	Ø 79	065N0057				

Spare Parts for hot tap valves

Top plug for packing box

Picture	Valve size (mm)	Code No.
	15	065N0010
	25	
	20	
	25	
	32	065N0011
	40	
	50	
	40	
	65	065N0012
	80	
	80	
	100	

Spare parts for hot tap tool box

Picture	Description	Details	Code No.
	JIP-HTT Accessory box	"Shaft opening pin (5 pcs) Accessory box Pilot Drills (90 mm and 2 pcs 120 mm) Allen key 3, 4 and 5mm Extension socket Gear fastening screw Chip magnet Drill Holder for Hole Saws > 30 and < 32 mm"	065N1008
	JIP-HTT Sealing set (for machine)	"Ret.Ring for Upper/Lower Bearing Upper/Lower PTFE-Bearing Base sealing Lip and shaft sealings Jr. Thrust Bearing Jr. Thrust retaining ring O-ring upper bearing"	065N1007
	JIP-HTT Sealing adapters set DN 20-100	Sealing adapter DN20-100 mm (8 pcs)	065N1020
	JIP-HTT Pilot drill normal (120mm)	5 pieces set of drills 120 mm	065N1009
	JIP-HTT Pilot drill short (90mm)	5 pieces set of drills 90 mm	065N1010
	JIP-HTT Tool set	"Shaft opening pin (5 pcs) Allen keys - 3, 4 and 5 mm Special wrench (2 pccs) Chip Magnet Pipe wrench 13 mm"	065N1006

Drills, saws and adapters

Picture	Valve size	Hole saw diameter	Code No.
	DN 15/20	Ø15	065N8020
	DN 25/32	Ø24	065N8012
	DN 40/50	Ø40	065N8013
	DN 65	Ø48	065N8093
	DN 80	Ø65	065N8014
	DN 100	Ø79	065N8097

Data sheet

JIP™ hot tap ball valves

Technical data

Nominal diameter	DN	15/20	25	32	40	50	65	80	100	
Nominal pressure	PN	40						25		
Temp range	°C	0-180								
Medium		Circulation water / glycolic water up to 50 %								

Design and material:

JIP Hot tap

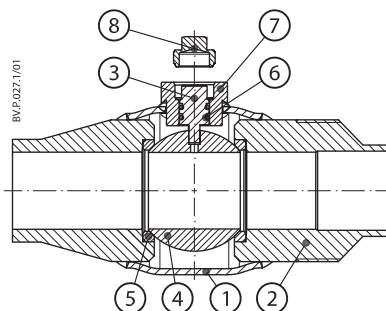

1	Valve body	Weldable mild steel P235GH / Mat. No. 1.0345 (~St. 37.0)
2	Welding ends	
3	Valve stem	Stainless steel X5CrNi18-10 (EN10088)/ W.nr. 1.4301 (~AISI 304)
4	Ball	
5	Seat rings	Carbon reinforced PTFE
6	O-rings	EPDM
7	Packing box	Weldable mild steel P235GH / Mat. No. 1.0345 (~St. 37.0)
8	Plug	

Hot tapping tool design

1. Metabo drilling machine with mounted reduction gear
2. Feeding wheel
3. Feed Extension Socket
4. Adjusting Handle
5. Tool body
6. Base Shaft
7. Shaft Extension
8. Drill holder
9. Hole Saw
10. Pilot Drill
11. Pressure Gauge
12. Shut off valve
13. Hot tap Ball valve

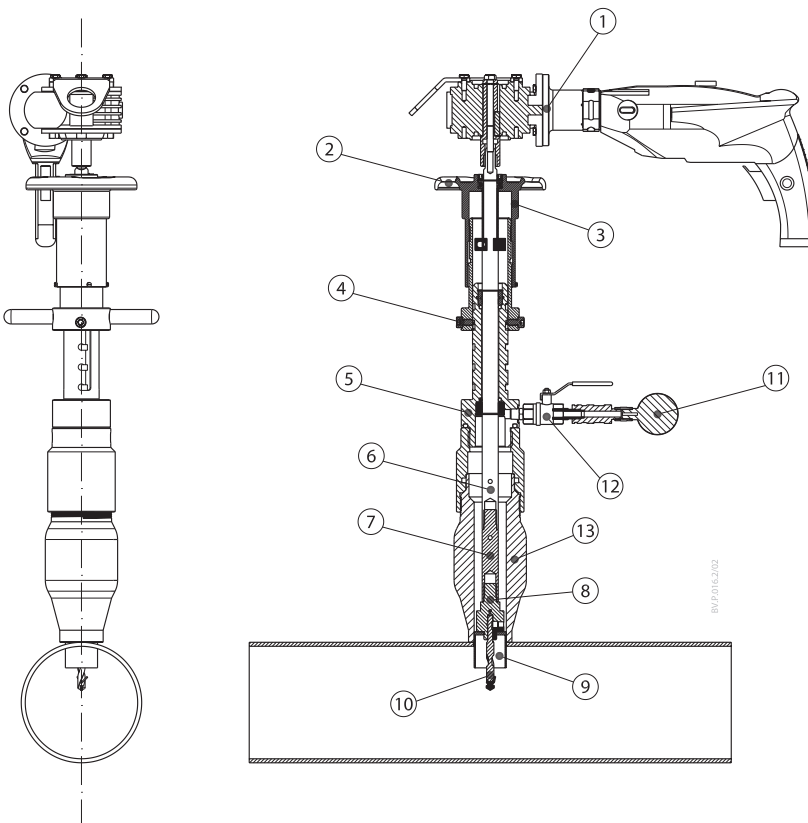

Toolbox design and parts

1. Metabo drilling machine with mounted reduction gear
2. Feed device
3. Base Shaft
4. Extension shaft
5. Special shaft DN 20
6. Pressure Monitoring Set 40 bar
7. Cutting paste
8. Sealant lubricant
9. Wrench
10. Accessory box
11. Pressure relief hose
12. Pipe wrench

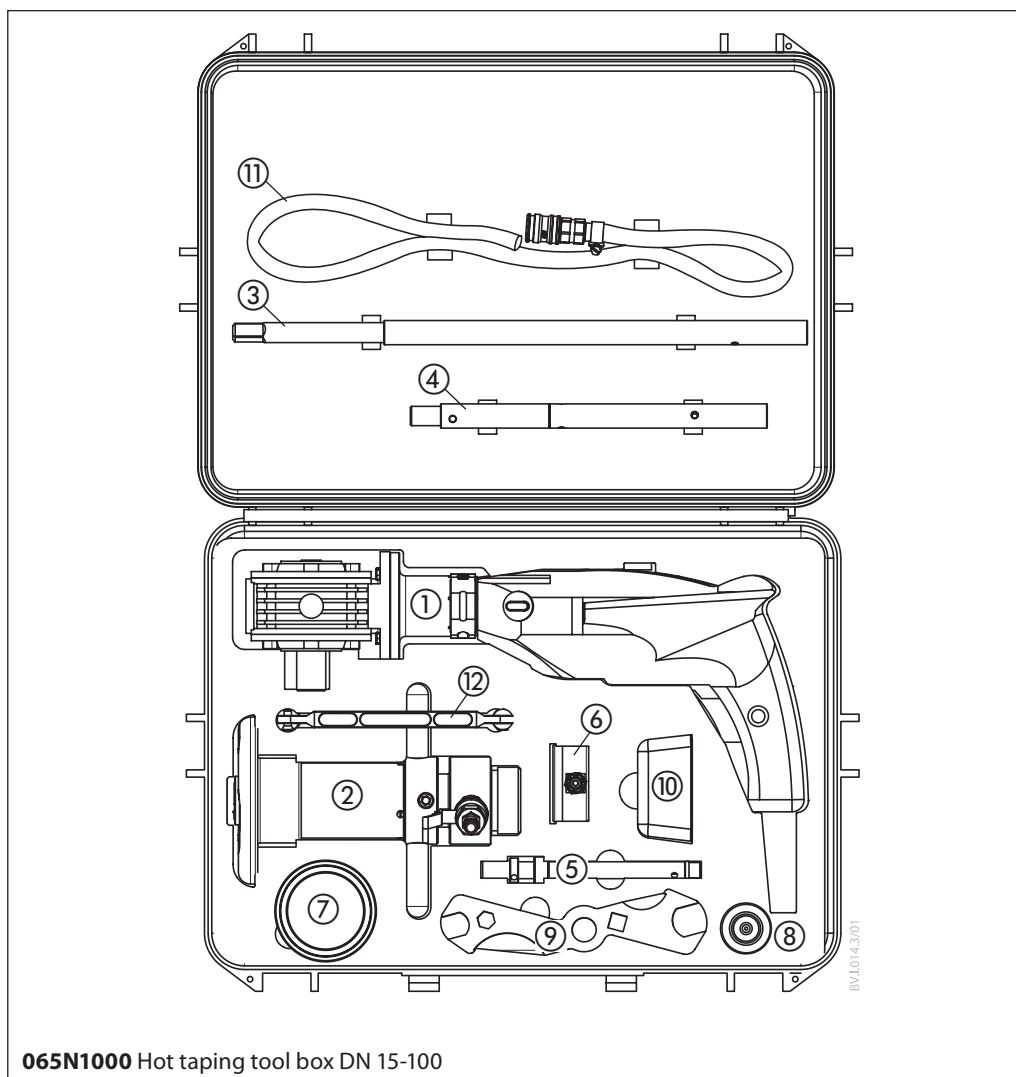

065N1000 Hot tapping tool box DN 15-100

Toolbox design and parts

1. Adapter socket DN 25/40
2. Allen key set
3. Adapter DN 15/20
4. Adapter DN 32
5. Allen key set
6. Spare sealing set
7. Pilot Drills
8. Adapter DN 100
9. Hole Saw HSS 15-100mm
10. Screwdriver 6mm
11. Adapters DN 50-80

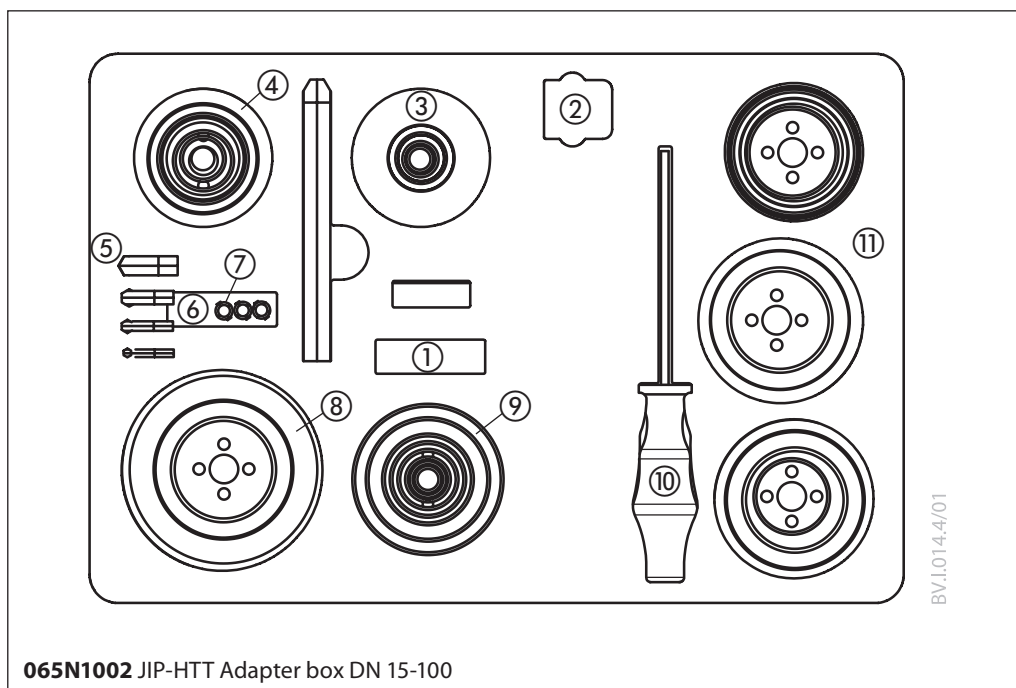

065N1002 JIP-HTT Adapter box DN 15-100

Toolbox design and parts

1. Adapter DN 15/20
2. Adapter socket DN 25
3. Adapter DN 32
4. Adapter socket DN 40
5. Adapter DN 50
6. Hole saws DN 15-DN 50
7. Screwdriver 6 mm
8. Spare sealing set
9. Pilot Drills HM normal and short
10. Allen key set 2.5-10 mm

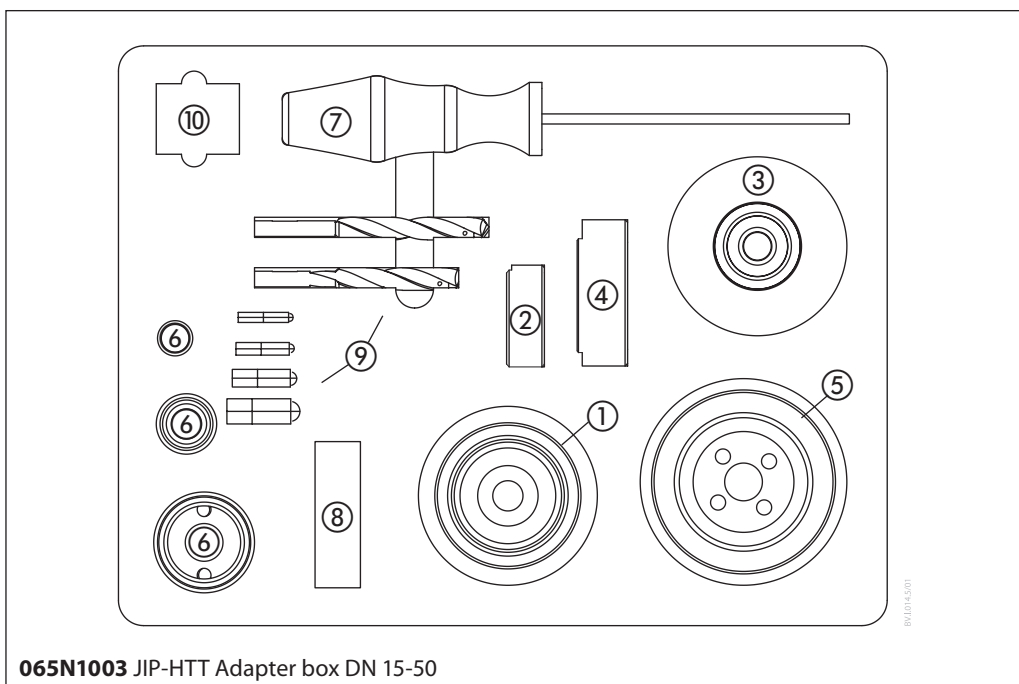

065N1003 JIP-HTT Adapter box DN 15-50

Toolbox design and parts

1. Adapter DN 65
2. Adapter DN 80
3. Adapter DN 100
4. Hole saws DN 65-DN 100
5. Spare sealing set
6. Allen key 14 mm
7. Allen key set 2.5-10 mm
8. Screwdriver 6 mm
9. Pilot Drills HM normal and short

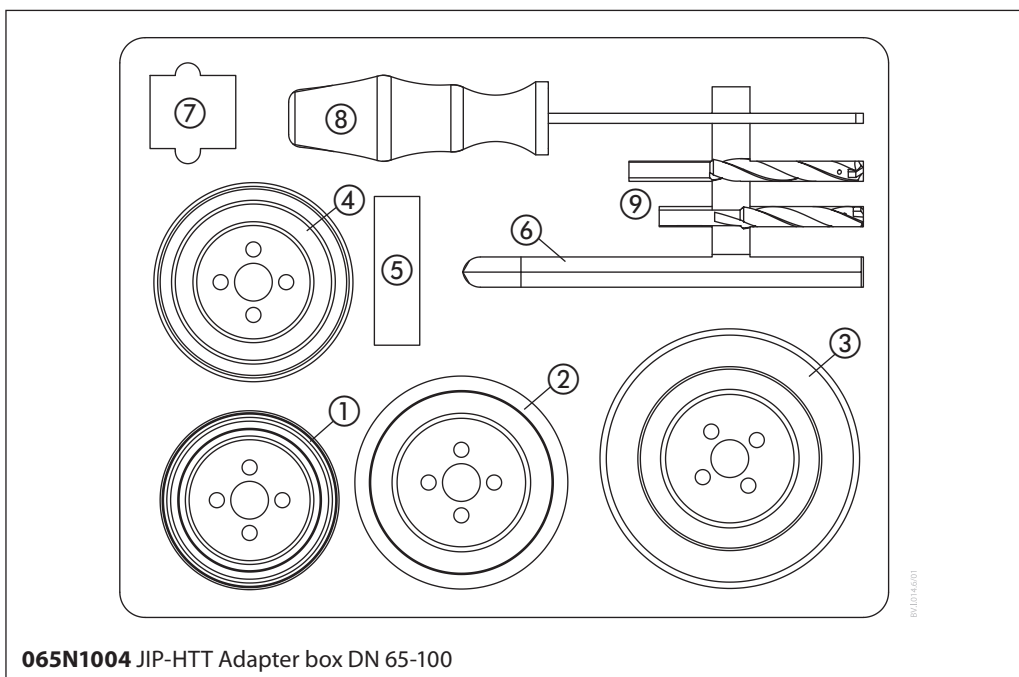

065N1004 JIP-HTT Adapter box DN 65-100

Pressure drop/flow diagram

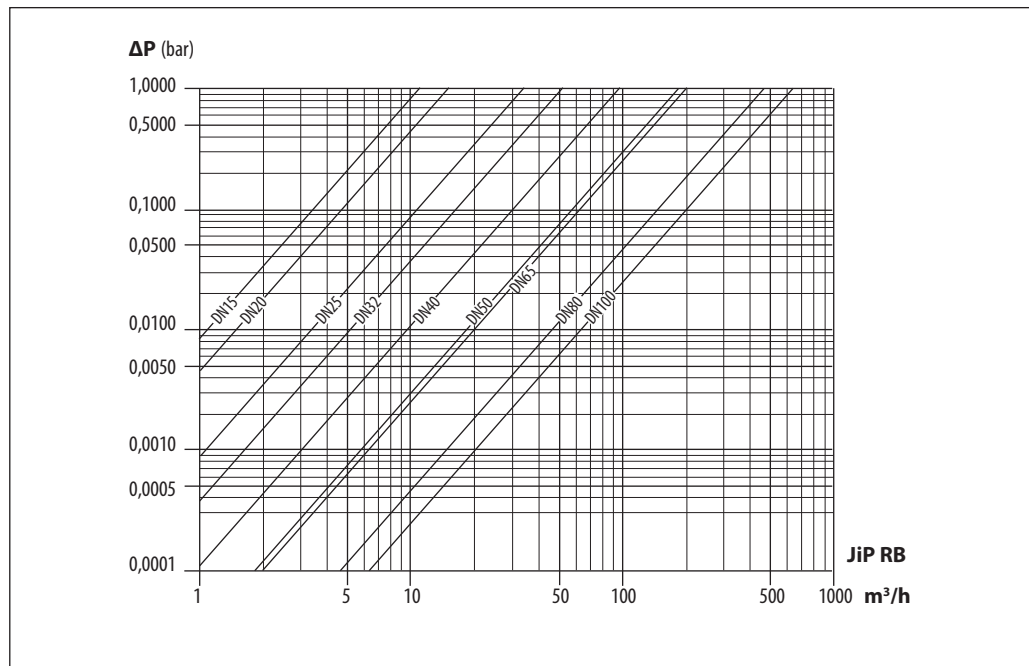

Pressure/temperature diagram

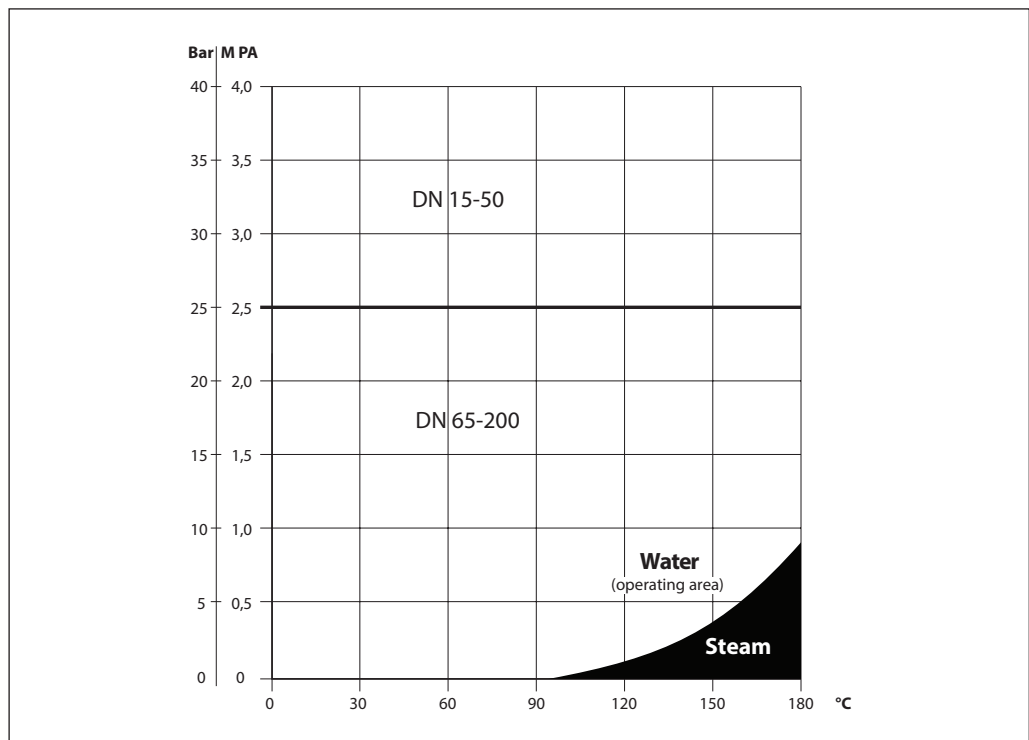

Dimensions

JIP hot tap

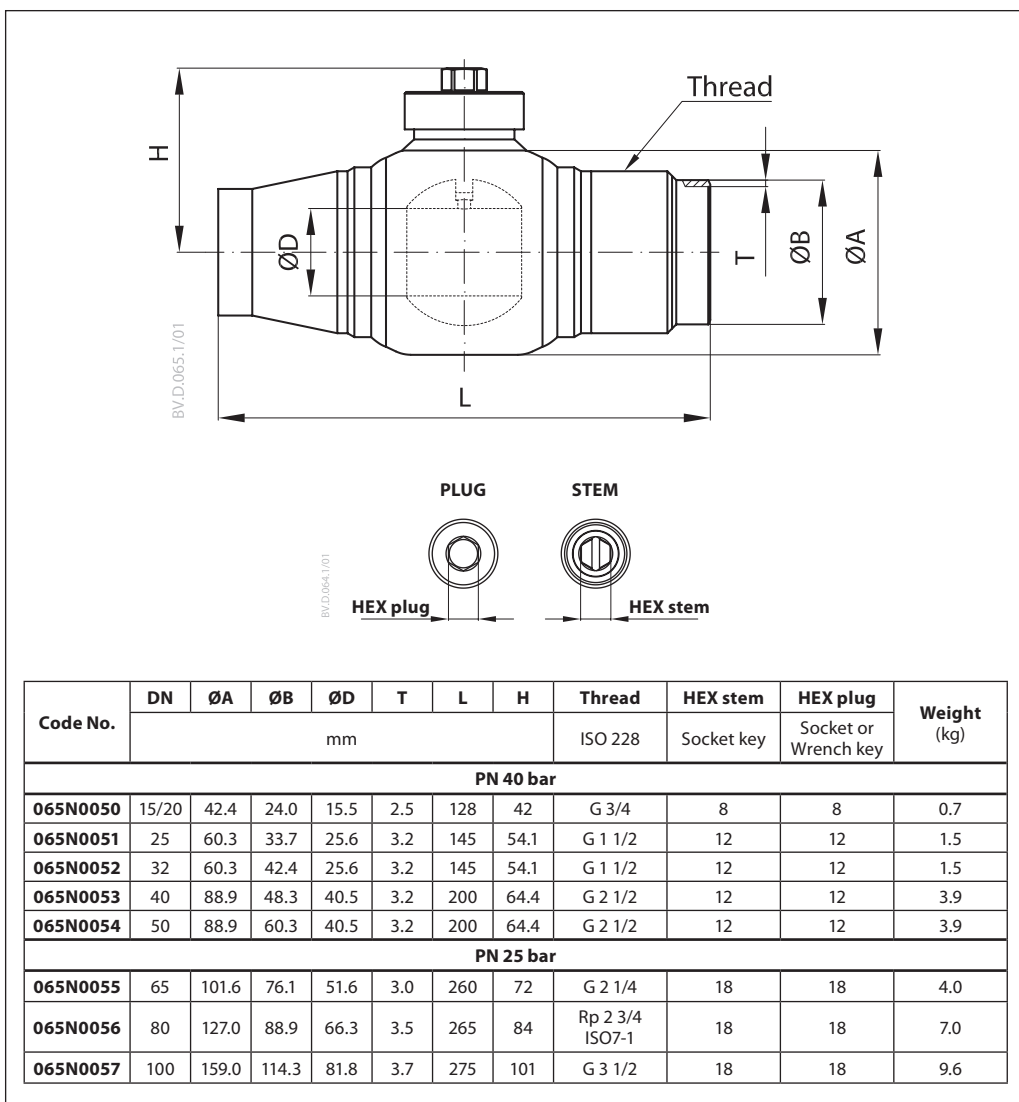



Danfoss A/S

Heating Segment • heating.danfoss.com • +45 7488 2222 • E-Mail: heating@danfoss.com

Danfoss can accept no responsibility for possible errors in catalogues, brochures and other printed material. Danfoss reserves the right to alter its products without notice. This also applies to products already on order provided that such alterations can be made without subsequential changes being necessary in specifications already agreed. All trademarks in this material are property of the respective companies. Danfoss and all Danfoss logotypes are trademarks of Danfoss A/S. All rights reserved.