

Fig. 4 DDG

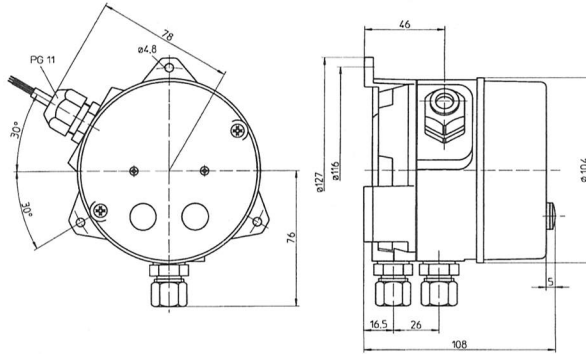

Fig. 5 DDG 2/100

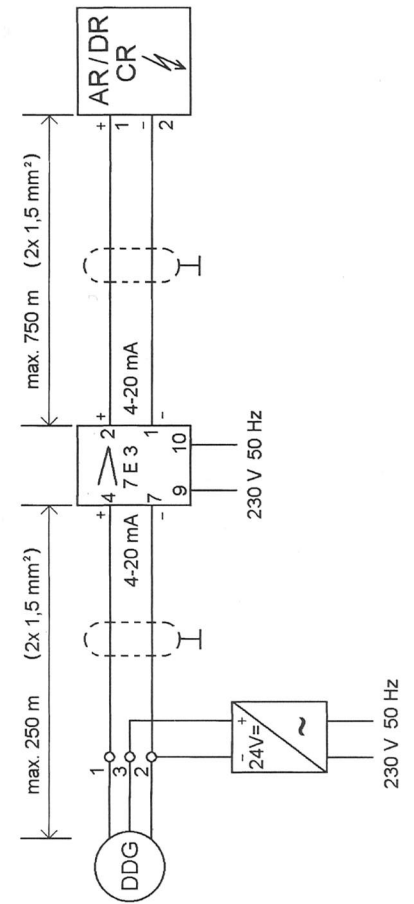

Fig. 6

1 General Information

Installation and service by qualified personnel only!

1.1 Uses

Via differential pressure measurements, signal transmitters provide the

switching signals for controlling the speed of circulating pumps and therefore for regulating the capacity of heating and similar systems.

The pressure difference indicator DDA has no signal transmitter function, but is only used for visual monitoring.

1.2 Connection and electrical data

	DDA	DDS	DDM	DDG
Output function	Display	1 x switching contact	2 x switching contact	Analog output 4-20 mA
Operating voltage / power consumption			250 V	15 - 30 V DC / 1.5 W
Max. contact rating		24 V/20 mA DC	250 V / 1 A AC	
Max. loading resistance				500 Ω
Power output				4 - 20 mA
System of protection		IP 54	IP 54	IP 54
Overpressure protection	25 bar	16 bar	16 bar	25 bar
Display / measurement range (Fig. no.)	6: 0 - 0.6 bar (1) 16: 0 - 1.6 bar (1)	6: 0 - 0.6 bar (2) 10: 0 - 1.0 bar (2) 16: 0 - 1.6 bar (2)	6: 0 - 0.6 bar (3) 10: 0 - 1.0 bar (3) 16: 0 - 1.6 bar (3) 25: 0 - 2.5 bar (3)	2: 0 - 0.2 bar (5) 10: 0 - 1.0 bar (4) 20: 0 - 2.0 bar (4) 40: 0 - 4.0 bar (4) 60: 0 - 6.0 bar (4) 100: 0 - 10.0 bar (5)
Media temperature	max. +85°C	0°C ... +80°C		0°C ... +70°C
Ambient temperature	-10°C ... +80°C	0°C ... +40°C		-10°C ... +50°C
Line length standard		5 m, 2 x 0.75 mm ²	5 m, 3 x 0.75 mm ²	5 m, 3 x 0.75 mm ² screened
Extension by customer		up to 100 m: 2 x 1.5 mm ²	up to 100 m: 3 x 1.5 mm ² up to 250 m: 3 x 2.5 mm ²	up to 25 m: 3 x 0.75 mm ² screened up to 100 m: 3 x 1.5 mm ² screened up to 250 m: 3 x 2.5 mm ² screened

2 Safety

The safety instructions are to be taken from the Installation and Operating Instructions of the connected switchgear / pumps and observed at all times.

3 Transport and storage

ATTENTION! This apparatus must be protected against moisture and mechanical damage.

It should not be exposed to temperatures outside the range -10 °C to +50°C.

4 Product and accessory description

4.1 Description of the transmitter or measuring devices

The transmitter is based on a robust diaphragm measuring device for measuring differential pressure. The diaphragm in a stable housing is subjected to a negative and positive pressure as prevails on the suction and pressure side of a pump. In the case of a difference in pressure the diaphragm bends towards the side of the lower pressure. The movement of the diaphragm is brought to the attention of a mechanic. At the same time, switching contacts are activated, or the movement is converted via a sensor into an electrical output signal.

The devices are protected against overloading. In response to extreme pressure differences the diaphragm pushes against the housing wall. The devices are fitted to the wall with fasteners to be provided by the customer. The connection of the device to the pressure measuring points is manufactured with copper pipes 6 mm in diameter. The connections are cutting ring screw connections. The installation of three-way manometer taps is recommended. The measuring lines are to be laid rising from the transmitter to the measuring points, so that air trapped in the lines can escape. Otherwise the device is to be fitted with a ventilation system.

4.1.1 Differential pressure indicator DDA (Fig. 1)

The DDA is suited to a great many measuring tasks in the fields of industrial and sanitary metrology.

4.1.2 Differential pressure switch DDS (Fig 2)

The DDS is essentially used as a two-state controller for Wilo AS controlling equipment.

The switching point can be infinitely varied using the adjusting knob between 15% and 100% of the full-scale value.

Where $\Delta p_{act} \geq \text{set value}$: contact closed,

where $\Delta p_{act} < \text{set value}$: contact open.

4.1.3 Differential pressure contact manometer DDM (Fig. 3)

The DDM is a 3-point controller for the universal assessment of differential pressure with the possibility of displaying 2 switching signals. They provide information on the area in which the differential pressure is occurring. The switch-over points can be set on the DDM.

The tappet of the diaphragm operates two micro-switches in different positions for higher or lower speed ranges. Both switches are designed as make contacts.

The switching threshold Δp_{min} for switching in higher speed ranges is set on the left knob of the DDM (Fig. 3, pos. 1).

If $\Delta p_{act} < \Delta p_{min}$, contact I, IV is closed. The switching threshold Δp_{max} for switching in lower speed ranges is set on the right knob (Fig. 3, pos. 2).

If $\Delta p_{act} > \Delta p_{max}$, contact I, II is closed. $\Delta p_{min} < \Delta p_{act} < \Delta p_{max}$: both contacts open.

Yellow flag	Lead no.
I	1
II	2
IV	3

4.1.4 Differential pressure transmitter DDG (Fig. 4/5)

The DDG is used as a signal transmitter for WILO controlling equipment (infinitely variable speed control). The line of motion of the tappet of the diaphragm is recorded by a measurement transformer and converted into electrical signals.

The electrical wiring is to be designed as follows:

	Terminals in DDG (Fig. 4, pos. 1)	Lead no.
+ 20 ... 30 V =	3	3
Mass \perp	2	2
4 ... 20 mA	A	1

If the zero-point position is not correct (recognisable by life-zero message at certain switching and regulating devices, e.g. CR system), a zero-point adjustment can be made.

- Differential pressure = 0 (if necessary unscrew pressure measuring lines),
- Measurement of voltage at the pins (Fig. 4, pos. 2),
- Set voltage to 0 V using potentiometer (Fig. 4, pos. 3).

In the case of line lengths greater than 250 m the DDG requires a measuring transducer (amplifier) to amplify the signal and a 24 V power supply unit for the power supply, which can be supplied as accessories (Fig. 6).

4.2 Products delivered

- Signal transmitter or indicator
- 2 cutting ring screw connections to DIN 3862, 6 mm diameter
- 2 Angle cutting ring screw connections R 1/8 x 6 mm diameter
- 5 m screened cable
- Installation and Operating Instructions

4.3 Accessories

Accessories must be ordered separately.

- 24 V = power supply unit for DDG
- Measuring transducer 7E3 (amplifier) for DDG, 230 V, 50 Hz

5 Maintenance

The devices are maintenance-free.

6 Problems, Causes and Solutions

If the fault cannot be remedied, please contact your plumbing and heating specialist or your nearest WILO customer services or representative.

Technical modifications reserved.