

Domo R wM-Bus Module 868 MHz

For single jet water meters DomoJet and multi jet water meters DomoMUK



Compact radio module with built-in bidirectional inductive sensor, designed for Sensus DomoJet and Domo MUK water meters. Domo R is also compatible with other models or meters from other brands that are suitable for use with the Modularis system.

Domo R is designed for reading remotely via radio the consumption data and alarms, ensuring ease and efficiency. It is ready for use and the factory settings enable both mobile (walk-by, drive-by) and fixed (AMR) reading. The factory settings can be changed later via radio with the configuration kit (optional).

FEATURES

- Bidirectional inductive sensor
- Direct mount, no cables needed, automatic activation of data transmission via radio
- 868 MHz, with open data protocol wM-Bus (EN 13757), OMS Certificate (DVGW cert OMS Group)
- Data transmitted: current volume, volume on the billing dates, meter's serial number, alarms.
- Mobile (walk-by, drive-by) or fixed (AMR) reading
- Battery lifetime 11 years + 1, replaceable
- Protection rating: IP67
- Compatible with Modularis

Based on the inductive principle, which ensures insensitivity to magnetic interference fields, the module's internal sensor detects the revolutions of the meter's pointer, calculates the volume (both directions) and manages the alarms.

The alarms managed are: overflow (threshold configurable, must be activated), backflow (threshold set, configurable), leak, meter blocked or non-used (days threshold set, configurable), magnetic and mechanical tampering (removal).

Domo R complies with the wM-Bus data communication protocol regulated at European level by the Standard EN 13757. This ensures large interoperability between different reading systems from other brands available on the market.

DomoJet with Domo R



Dimensions

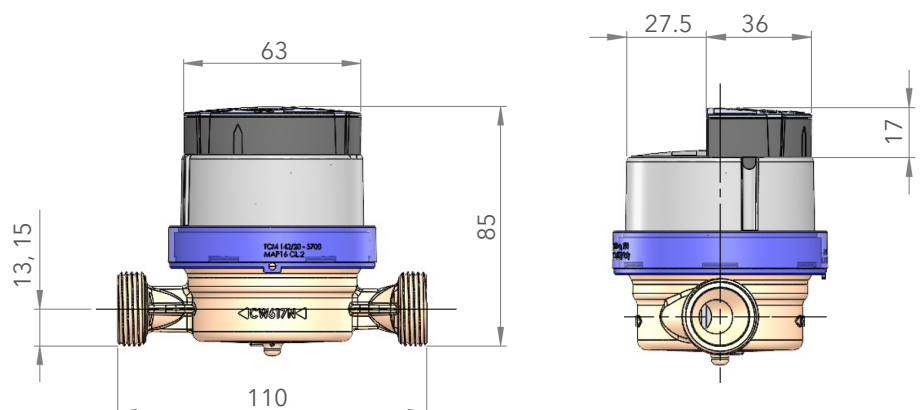

Domo R wM-Bus Module 868 MHz

For single jet water meters DomoJet and multi jet water meters DomoMUK

TECHNICAL SPECIFICATIONS

Sensor	Inductive, dual spool (bidirectional)	
Compatible Meters	DomoJet, DomoMUK	
Sensor Resolution	1 Litre	
Alarms	Tampering, magnetic fraud, backflow, suspected leak, meter blocked, maximum flow rate, meter inverted	
Configuration	Via radio	
Power Supply	Lithium-ion battery (replaceable), 11 years + 1 year storage*	
Approvals	CE in accordance with the European standards EMC: EN 61000-4-2, EN 61000-4-3, ETSI EN 301 489-1, ETSI EN 301 489-3, ETSI EN 300 220-2 ISO 4064-1 (in connection with DomoJet resp. DomoMUK)	
Radio	Standard	Wireless M-Bus, OMS*
	Modes	T1*, C1
	Frequency	868 MHz
	Transmission Distance	500 m in line of sight
	Reference Standards	EN 13757
	Data Transmitted	Short frame*: current volume, volume on the billing dates, meter's serial number, alarms Long frame: same as the short frame with the values of the previous 12 months
Environmental Conditions	Storage temperature: -20 °C ÷ +60 °C Operating temperature: -10 °C ÷ +55 °C	
Protection Rating	IP67	

* Factory settings, configurable

Data Collection Devices And Software

Sensus offers a full range of mobile (walk-by) and fixed (AMR) radio transceivers. They are both compatible with Sensus water meters with wM-Bus interface and with water meters from other brands compliant with the Standard EN 13757.

The main devices for mobile reading are described below.

SIRT Receiver (868 MHz)

Enables readout via radio from wM-Bus devices with OMS protocol. Also available as a variant with external antenna. Economical, user-friendly solution.

Evo Configurator

Windows Configuration Software for use in combination with USB transmitting and receiving devices. Available for download at www.sensus.com.

USB Transceiver 868 MHz

Powerful, fast wM-Bus radio receiver. Usable with wM-Bus devices and OMS protocol. Windows reading and configuration software.

DIAVASO

Mobile software readout via Android using the SIRT (Sensus Interface Radio Tool) radio modem. Further information are available on www.sensus.com



Xylem.com | Sensus.com

UK & Ireland Inquiries | Sensus UK Systems Ltd. | 3 Lindenwood Crockford Lane, Chineham Business Park | Basingstoke RG24 8QY UK | +44 1256 372800 | info.gb@xylem.com

International Inquiries | Sensus GmbH Hannover | Meineckestr. 10 | 30880 Laatzen | Germany | +49 5102 743177
info.int@xylem.com

©2020 Sensus. All products purchased and services performed are subject to Sensus' terms of sale, available at sensus.com. Sensus reserves the right to modify these terms and conditions in its own discretion. The Sensus logo and other Sensus products or services referenced are registered trademarks of Sensus.

This document is for informational purposes only, and SENSUS MAKES NO EXPRESS WARRANTIES IN THIS DOCUMENT. FURTHERMORE, THERE ARE NO IMPLIED WARRANTIES, INCLUDING WITHOUT LIMITATION, WARRANTIES AS TO FITNESS FOR A PARTICULAR PURPOSE AND MERCHANTABILITY. ANY USE OF THE PRODUCTS THAT IS NOT SPECIFICALLY PERMITTED HEREIN IS PROHIBITED.

