



Main characteristics

- Meter with MID pattern approval acc. to annex MI001
- Exchangeable metrological unit with MID pattern approval acc. to annex MI001
- Unique measuring range; $Q_3/Q_1 \geq 100$
- High overload capability
- No straight inlet length necessary (U0D0 acc. to OIML R49 and EN 14154)
- Installation position horizontal and vertical
- Meter body in short (WP) and long (WS) overall length acc. to DIN 19625 and ISO 4064-1:2014 available
- Meter can be submerged; protection class IP68
- Used materials are temperature resistant up to 70 °C
- Register prepared for HRI-Mei pick-up
- Use of optical pulsers type OD is still possible

Applications

- Measurement for billing of cold potable water up to 50 °C
- Measurement of high flowrates e.g. in pumped pipes
- Measurement of low flow e. g. in light load periods
- For leakage detection

Available options

- Encoder register with different data protocols (M-Bus, Sensus, IEC 1107)
- Version free of copper alloy for aggressive water (DN 40 ... 150)
- Register with 7 digits without multiplier (DN 150 ... 300)
- Version for high pressure up to PN 40 (DN 50 ... 150)
- Version for use in hazardous area
- HRI-Mei factory mounted
- 1/4" pressure monitoring port

Performance Data

Metrological Data acc. to Manufacturers Values

	Size	DN	40	50	65	80	100
Q_s	Max. Peak Flow	m ³ /h	60	90	120	200	300
Q_3'	Continuous Flow	m ³ /h	40	50	70	120	230
Q_{2h}	Transitional Flowrate horizontal	m ³ /h	0.32	0.4	0.63	0.51	0.81
Q_{1h}'	Minimum Flow horizontal	m ³ /h	0.2	0.15	0.2	0.2	0.3
Q_{2v}	Transitional Flowrate vertical	m ³ /h	0.4	0.51	0.81	0.8	1.28
Q_{1v}'	Minimum Flow vertical	m ³ /h	0.25	0.28	0.4	0.5	0.5
	Starting Flow	m ³ /h	0.05	0.05	0.07	0.1	0.11

	Size	DN	125	150	200	250	300
Q_s	Max. Peak Flow	m ³ /h	350	600	1200	1600	2000
Q_3'	Continuous Flow	m ³ /h	250	450	800	1250	1400
Q_{2h}	Transitional Flowrate horizontal	m ³ /h	1.02	1.6	4.0	6.3	16.0
Q_{1h}'	Minimum Flow horizontal	m ³ /h	0.5	0.8	2.0	3.5	9.0
Q_{2v}	Transitional Flowrate vertical	m ³ /h	1.6	3.2	4.0	10.1	25.4
Q_{1v}'	Minimum Flow vertical	m ³ /h	1	1.6	2.5	6.3	15.9
	Starting Flow	m ³ /h	0.15	0.3	1.5	3	8

Metrological Data acc. to 2014/32/EU (MID)

	Size	DN	40	50	65	80	100
Q_4	Overload Flowrate acc. to MID	m ³ /h	31.25	50	78.75	125	200
Q_3	Permanent Flowrate acc. to MID	m ³ /h	25	40	63	100	160
Q_{2h}	Transitional Flowrate horizontal acc. to MID	m ³ /h	0.32	0.4	0.63	0.51	0.81
Q_{1h}	Minimum Flowrate horizontal acc. to MID	m ³ /h	0.2	0.25	0.39	0.32	0.51
Q_{2v}	Transitional Flowrate vertical acc. to MID	m ³ /h	0.4	0.51	0.81	0.8	1.28
Q_{1v}	Minimum Flowrate vertical acc. to MID	m ³ /h	0.25	0.32	0.5	0.5	0.8
Q_3/Q_1 h	Max. Ratio horizontal		125	160	160	315	315
Q_3/Q_1 v	Max. Ratio vertical		63	100	100	125	160
Q_3/Q_1	Standard Marking		63	100	100	100	100
Δp	Headloss at Q_3 acc. to ISO 4064-1:2014	bar	0.1	0.16	0.32	0.16	0.34

	Size	DN	125	150	200	250	300
Q_4	Overload Flowrate acc. to MID	m ³ /h	200	500	787.5	787.5	1250
Q_3	Permanent Flowrate acc. to MID	m ³ /h	160	400	630	630	1000
Q_{2h}	Transitional Flowrate horizontal acc. to MID	m ³ /h	1.02	1.6	4.03	8.06	25.4
Q_{1h}	Minimum Flowrate horizontal acc. to MID	m ³ /h	0.64	1	2.52	5.04	15.9
Q_{2v}	Transitional Flowrate vertical acc. to MID	m ³ /h	1.6	3.2	4.03	10.1	25.4
Q_{1v}	Minimum Flowrate vertical acc. to MID	m ³ /h	1	2	2.52	6.3	15.9
Q_3/Q_1 h	Max. Ratio horizontal		250	400	250	125	63
Q_3/Q_1 v	Max. Ratio vertical		125	200	250	100	63
Q_3/Q_1	Standard Marking		100	100	100	100	63
Δp	Headloss at Q_3 acc. to ISO 4064-1:2014	bar	0.19	0.27	0.11	0.07	0.08

Typical Headloss

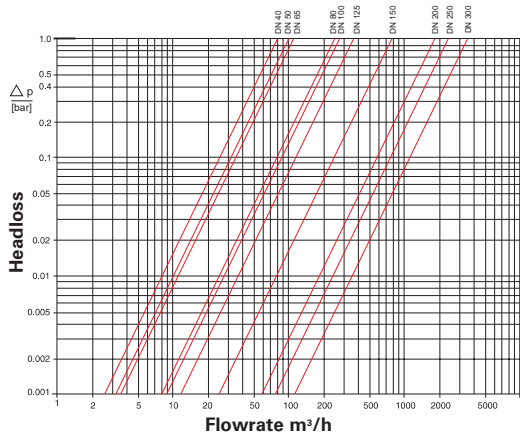

Typical Error Curve

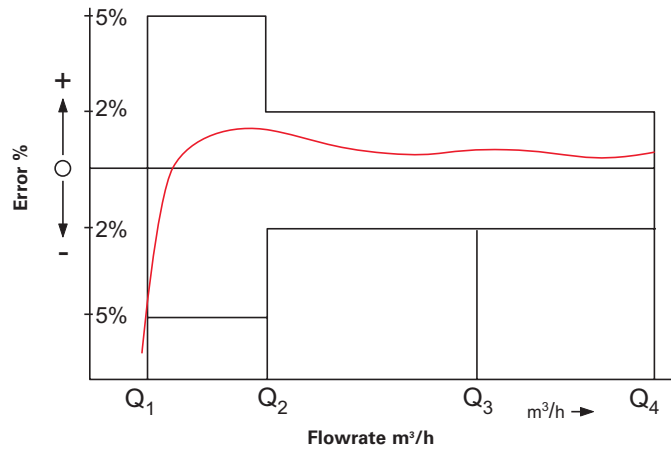

Dial

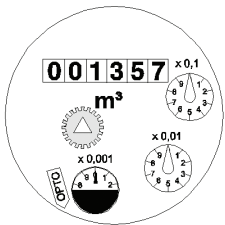

DN 40...125

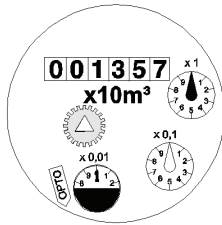

DN 150 ... 300

Nominal diameter DN	Smallest reading m³	Max. reading m³
40 ... 125	0.0005	999,999.999
150 ... 300	0.005	9,999,999.99

Pulse Values

Pulser Type	DN 40 ... 125	Pulse Value	DN 150 ... 300
OD 01 (Leaflet see LB 8300)	0.001 m³		0.01 m³
OD 03 (Leaflet see LB 8300)	0.01 m³		0.1 m³

Installation

Pipe	horizontal vertical	
Meter head	upwards sideways	

Installation Requirements

- Unrestricted straight pipe upstream 0 x DN
- No abrupt restrictions directly downstream of the meter

Materials

Body	Cast iron (PN16) Ductile iron (PN40)
Measuring element	Plastic
Rotor	Plastic
We also use the following materials	Brass Stainless steel

Available Lengths

Nominal diameter		40	50	65	80	100	125	150	200	250	300
Overall length L WS (DIN / ISO)	mm		270 / 300*	300	300 / 350*	360 / 350*		500			
Overall length L WP (DIN / ISO)	mm	220*	200	200*	225 / 200*	250	250*	300	350	450	500

* PN16 only

Approval Mark

Meter cpl. and exchangeable metrological unit

Marking CE M-XX* 0102

DN 40 ... 150: DE-09-MI001-PTB 010
DN 200 ... 300: DE-15-MI001-PTB 014

* year of production

Dimension Picture

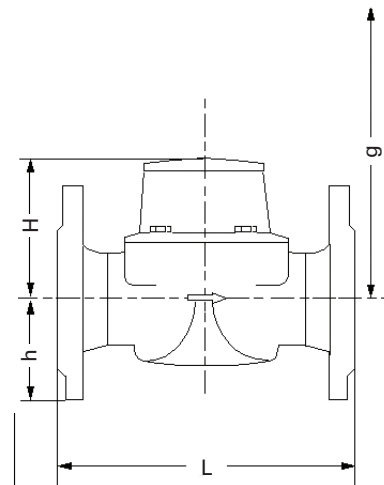

Order example

MeiStream, DN 50, T50, PN16	Type
Drilling EN 1092 PN16	Size
Length 270 mm	Max. medium temperature
mechanical register / m ³	Nominal pressure
with MID conformity	Drilling pattern
	Body length
	Register type / unit
	Approval standard

Dimensions and Weights

Dimensions

Nominal diameter		DN	40	50	50	50	65	65
Overall length	L	mm	220	200	270	300	200	300
Height	H	mm	120	120	120	120	120	120
	h	mm	69	73	73	73	85	85
Dismantling height	g	mm	200	200	200	200	200	200

Nominal diameter		DN	80	80	80	80	100	100	100
Overall length	L	mm	200	225	300	350	250	350	360
Height	H	mm	150	150	150	150	150	150	150
	h	mm	95	95	95	95	105	105	105
Dismantling height	g	mm	270	270	270	270	270	270	270

Nominal diameter		DN	125	150	150	200	250	300
Overall length	L	mm	250	300	500	350	450	500
Height	H	mm	160	177	177	214	238	264
	h	mm	118	135	135	162	194	226
Dismantling height	g	mm	280	356	356	449	474	499

Weight PN16

Nominal diameter		DN	40	50	50	50	65	65
Overall length	L	mm	220	200	270	300	200	300
Meter cpl.		kg	7.5	7.8	9.6	9.9	10.1	12.0
Measuring unit		kg	1.5	1.5	1.5	1.5	1.5	1.5
Body		kg	6.0	6.3	8.1	8.4	8.6	10.5

Nominal diameter		DN	80	80	80	80	100	100	100
Overall length	L	mm	200	225	300	350	250	350	360
Meter cpl.		kg	13.8	14.2	16.3	17.7	18.2	20.0	20.2
Measuring unit		kg	3.2	3.2	3.2	3.2	3.2	3.2	3.2
Body		kg	10.6	11.0	13.1	14.5	15.0	16.8	17.0

Nominal diameter		DN	125	150	150	200	250	300
Overall length	L	mm	250	300	500	350	450	500
Meter cpl.		kg	20.7	35.9	44.2	56.9	79.4	103.8
Measuring unit		kg	3.2	5.9	5.9	9.6	9.6	9.6
Body		kg	17.5	30.0	38.3	47.3	69.8	94.2

Weight PN40

Nominal diameter		DN	50	50	65	80	80	100	100	150	150
Overall length	L	mm	200	270	300	225	300	250	360	300	500
Meter cpl.		kg	9.7	10.7	13.1	17	18.6	20.4	22.9	44.6	52.9
Measuring unit		kg	1.7	1.7	1.7	4	4	4	4	9.3	9.3
Body		kg	8	9	11.4	14.6	14.6	16.4	18.9	35.3	43.6



qualityaustria
Succeed with Quality

Certified according to ISO 9001
Quality Management System Quality Austria Reg.no. 3496/0

UK & Ireland Enquiries

Sensus UK Systems Ltd, 3 Lindenwood Crockford Lane, Chineham Business Park
Basingstoke RG24 8QY UK
T: +44 (0) 1256 372800 F: +44 (0) 1256 707203 Email: info.gb@xyleminc.com www.sensus.com

International Enquiries

Sensus GmbH Hannover, Meineckestraße 10, D-30880 Laatzen Germany
T: +49 (0) 5102-74-0 F: +49 (0) 5102-74-3341 Email: info.int@xyleminc.com www.sensus.com