

Pioneering for You

- CIF-Modul Modbus RTU (2190368)
(type list)

wilo

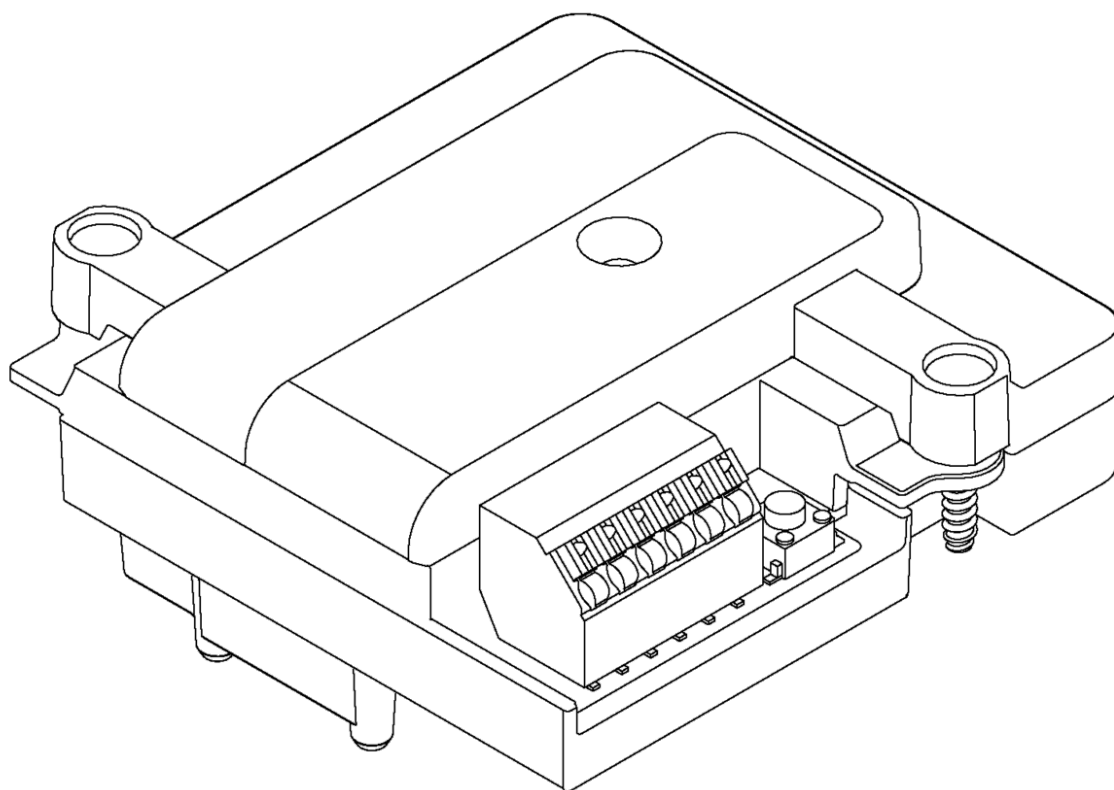

en Installation and operation instructions with functional description

1 General

1.1 About this document

The language of the original operating instructions is German. All other languages of these instructions are translations of the original operating instructions.

These installation and operating instructions are an integral part of the product. They must be kept readily available at the place where the product is installed. Strict adherence to these instructions is a precondition for the proper use and correct operation of the product.

These installation and operating instructions correspond to the relevant version of the product and the underlying safety standards valid at the time of going to print.

2 Safety

These operating instructions contain basic information which must be adhered to during installation and operation. For this reason, these operating instructions must, without fail, be read by the service technician and the responsible operator before installation and commissioning.

It is not only the general safety instructions listed under the main point "safety" that must be adhered to but also the special safety instructions with danger symbols included under the following main points.

2.1 Indication of instructions in the operating instructions

Symbols:



General danger symbol



Danger due to electrical voltage



Note

Signal words:

DANGER!

Acutely dangerous situation. Non-observance results in death or the most serious of injuries.

WARNING!

The user can suffer (serious) injuries. 'Warning' implies that (serious) injury to persons is probable if this information is disregarded.

CAUTION!

There is a risk of damage to the product/unit. 'Caution' implies that damage to the product is likely if this information is disregarded.

NOTE: Useful information on handling the product. It draws attention to possible problems.

2.2 Personnel qualifications

The installation, maintenance and repair personnel must have the necessary qualifications for this work.

2.3 Danger in the event of non-observance of the safety instructions

Non-observance of the safety instructions can result in risk of injury to persons and damage to product/unit. Non-observance of the safety instructions will result in the loss of any claims to damages.

In detail, non-observance can, for example, result in the following risks:

- Failure of important product/unit functions
- Failure of required maintenance and repair procedures
- Danger to persons from electrical, mechanical and bacteriological influences
- Property damage

2.4 Safety instructions for the operator

The existing directives for accident prevention must be adhered to. Danger from electrical current must be eliminated. Local directives or general directives [e.g. IEC, VDE etc.] and those of local power supply companies must be adhered to.

This device may be used by children with an age of 8 years or above as well as by persons with reduced corporal, sensorial or mental capacity or lack of experience and/or lack of knowledge, if they are supervised or instructed regarding the safe operation of the device and understand the resulting dangers. Children shall not play with the device. Cleaning or user maintenance shall not be performed by children without supervision.

2.5 Safety instructions for inspection and installation work

The operator must ensure that all inspection and installation work is carried out by authorised and qualified personnel, who are sufficiently informed from their own detailed study of the operating instructions.

Work on the product/unit should only be carried out when it has been brought to a standstill. It is mandatory that the procedure described in the installation and operating instructions for shutting down the product/unit be complied with.

2.6 Unauthorised modification and manufacture of spare parts

Modifications to the product are only permissible after consultation with the manufacturer. Original spare parts and accessories authorised by the manufacturer ensure safety. The use of other parts can nullify the liability from the results of their usage.

2.7 Improper use

The operating reliability of the supplied product is only guaranteed if the product/unit is used as intended in accordance with Section 4 of the operating instructions. The limit values must on no account fall under or exceed those specified in the catalogue/data sheet.

3 Transport and interim storage

3.1 Scope of delivery

- CIF-Module
- Installation and operating instructions
- cable gland(s) (M16x1.5)

3.1 Inspection after transport

Immediately check for any transit damage and/or completeness on arrival. Complain immediately if necessary.



CAUTION! Danger of damage to the CIF-Module! Danger of damage due to incorrect handling during transportation and storage.

The unit must be protected from moisture, frost and mechanical damage during transport and interim storage.

4 Intended Use

The CIF-Modules are designed for external control and operating status signalling of Wilo pumps. The CIF-Modules are not designed for safe deactivation of the pump.



DANGER! Risk of injury and material damage!

Never user the control inputs for safety functions.

Never mount the CIF-Module in a non compatible device.

4.1 Compatibility of firmware

This document is valid for a firmware version of up to 3.00 of the CIF-module.

To ensure the functionality of the module the following (or higher) firmware versions for the product where the CIF-module is mounted are necessary:

Pump	Version	Remark
WILO Stratos Maxo	1.00	

Fig. 4.1.1: product types

For compatibility with products not listed above, refer to www.wilo.com/automation (<http://www.wilo.com/automation>)

5 Product information

5.1 Type key

Example: CIF-Module Modbus RTU

Key	Description
CIF-Module	Communication Interface Module
Modbus	Model/function identifier: Modbus RTU= RS485 interface, Modbus RTU protocol BACnet MS/TP= RS485 interface, BACnet MS/TP protocol

Fig. 5.1.1: type key

5.2 Technical Specification

Technical Specification

General data

Terminal cross-section (finely stranded, no ferrules)	1.5 mm ² (max)
Electric circuit	SELV, galvanically isolated
Interface RS485 in accordance with TIA-485-A	
Load (unit load)	1/8
Input voltage	Max. 12 V (differential A-B)
Termination resistor	120 Ω (integrated, switchable)

Fig. 5.2.1: technical data

5.4 Standards

The CIF-Modules Modbus RTU comply to MODBUS APPLICATION PROTOCOL SPECIFICATION V1.1 and Modbus Serial line protocol V 1.02 in transmission mode RTU available at [modbus.org](http://www.modbus.org/specs.php) (<http://www.modbus.org/specs.php>).

6 Description and function

The CIF-modules expand the the device with communication capability for various standards.

Further information available at www.wilo.com/automation (<http://www.wilo.com/automation>)

6.1 Description

When registers are 32 Bits wide (including REAL), the the most significant part ist stored at the base address, the least significant part is stored at base address +1.

When registers are 64 Bits wide (including LREAL), the the most significant part ist stored at the base address, the least significant part is stored at base address +3.

6.1.1 Command priority

Beside the normal on/off control of the pump there are several methods to override this. The following list shows the priority of those commands. Lower numbers have higher priority

1. Override off

2. Override max
3. Override min
4. Override on

6.1.2 Compatibility

6.1.2.1 Function $\Delta p-c = F(T)$

For pumps from the Stratos series a simple fluid temperature dependent variation of the delivery head was available as control function. Via IF-module, IR-Monitor or even IR-Stick, adjustment of parameters T_{min} / T_{max} and $p(T_{min})$ / $p(T_{max})$ was possible.

Pumps with CIF-Modules support a full featured constant temperature control with a sensor mounted directly in the fluid. The datapoints for the legacy function are still existing but without any function.

For usage of this function, select the mode "T-const" from the basic control functions.

As setpoint source "internal setpoint" has to be selected.

A simple approach for adjustment may be to select the mean value of former T_{min} and T_{max} values as setpoint for the temperature control. There is no general recommendation for the settings. Also WILO does not guarantee full compatibility between $\Delta p-c = F(T)$ and T-const control.

6.1.2.4 CIF-Modules - details of Master and/or Slave

For CIF modules, the data of the master and slave pump are not available individually (even if defined on the interface for compatibility). Only data of the system is provided. To achieve maximum compatibility in existing applications, all datapoints with the scope "master" show values of the pump system while all datapoints with the scope "slave" deliver the error value (if applicable) or a static value. Nevertheless, the pump on signal is provided individually.

6.1.3 Scaling

When a scale is mentioned in the following sections, this is always a presentation scale. Read values have to be multiplied by this factor to get the result for presentation.

The setpoint (duty point (rel.)) is defined as a percentage. To scale to absolute values, you may use one of the values speed max-pres value / max pressure dp-c / max pressure dp-v which represent 100 % for the specific control function. A more generic approach is available for software versions 3.00 or higher. Here we provide a duty point 100% value indication the absolute value corresponding 100 %, the physical unit of this 100 % value (duty point (rel.) units) and additionally the relative limits of the duty point (duty point (rel.) min.-output / duty point (rel.) max.-output).

6.1.4 Datatypes

data type	Bit	min	max	encoding	description
BOOL	1	0	1		boolean (bit) - can be true or false
BYTE	8	0	255		used for e.g. bitsets, no error value
DATE	32				date
DINT	32	-2147483648	2147483647		signed numeric value
DWORD	32	0	4294967295		used for e.g. bitsets, no error value
INT	16	-32768	32767		signed numeric value
LINT	64				signed numeric value
LREAL	64				floating point value according IEEE754
LWORD	64				used for e.g. bitsets, no error value
REAL	32	-3.4028234663852886e38	3.4028234663852886e38		floating point value according IEEE754
SINT	8	-128	127		signed numeric value
STRING				US-ASCII	string with variable length up to declared maximum size
TIME	32				time of day up to 24 hours (resolution 1 ms)
TIME_OF_DAY	32				time of day
UDINT	32	0	4294967295		unsigned numeric value
UINT	16	0	65535		unsigned numeric value
ULINT	64				used for e.g. bitsets, no error value
USINT	8	0	255		unsigned numeric value
WORD	16	0	65535		used for e.g. bitsets, no error value
WSTRING				UNICODE	string with variable length up to declared maximum size

6.1.5 Error Values

In the subsequent sections, the keyword "error value " appears in the functional description. If a read value is identical to the error value, it indicates that the reading is not available or invalid. Sometimes error values are also indicated for write values. In this case, writing the error value may invalidate the functionality of this datapoint.

6.2 Function

This Modbus implementation supports the function codes 03, 04, 06 and 16.



NOTE: All register addresses are raw addresses as they are transferred over the trunk. Sometimes an offset of 1 applies.

6.2.7.3 Holding Registers

address	name
1	duty point (rel.)
40	Pump Command
42	Control Function
44	$\Delta p-c = f(T)$ Regulation Tmin
45	$\Delta p-c = f(T)$ Regulation Tmax
46	$\Delta p-c = f(T)$ Regulation $\Delta p(Tmin)$
47	$\Delta p-c = f(T)$ Regulation $\Delta p(Tmax)$
300	Bus Command Timer
302	temperature reference T1
304	temperature reference T2
400	Bus Command Timer Timeout
401	Setpoint Signal Source
402	duty point (rel.) preset
403	Control Function preset
404	Pump Command preset
405	Setpoint Signal Source preset
408	PID Kp
409	PID Ti
410	PID Td

6.2.7.3.1 duty point (rel.)

property	value
address	1
scope	pump system
function	input value
data type	INT
unit	%
scale	0.5
range low	-32768
range high	32766
error value	32767
Module versions	CIF-Module Modbus RTU (1.00...99.99)

(signal-ID: 1)

This is the base signal. It contains the relative duty point of the device. The valid range is not necessarily 0...100 %. a duty point of 0 % is not necessarily linked to the OFF state of the device.

Support reference: CIF-/IF-Module mapped; Stratos; IL_E, ...; MVIE, ...;

6.2.7.3.40 Pump Command

property	value
address	40
scope	pump system
function	input value
data type	BYTE
Module versions	CIF-Module Modbus RTU (1.00...99.99)

(signal-ID:)

bit	Name	description	support	version
0	Pump on	This is the base signal. This signal represents the normal "ON" command. This signal is effective, if no override functions are active.	GLANDLESS, GLANDED_SINGLE, GLANDED_MULTI, STRATOS_MAXO	CIF-Module Modbus RTU (1.00... 99.99), IF-Module Modbus Stratos (1.13... 99.99), IF-Module Modbus (1.13... 99.99)
1	Override min	This is the base signal. This signal overrides the pump (system) command with "MIN" command.	GLANDLESS, GLANDED_SINGLE, GLANDED_MULTI, STRATOS_MAXO	CIF-Module Modbus RTU (1.00... 99.99), IF-Module Modbus Stratos (1.13... 99.99), IF-Module Modbus (1.13... 99.99)
2	Override max	This is the base signal. This signal overrides the pump (system) command with "MAX" command.	GLANDLESS, GLANDED_SINGLE, GLANDED_MULTI, STRATOS_MAXO	CIF-Module Modbus RTU (1.00... 99.99), IF-Module Modbus Stratos (1.13... 99.99), IF-Module Modbus (1.13... 99.99)
3	TRUE	This is the base signal. This signal represents a static '1' bit, typically for compatibility purpose. For write acces, this bit shall always be '1'.	PLC_INT	CIF-Module Modbus RTU (1.00... 99.99), IF-Module Modbus Stratos (1.13... 99.99), IF-Module Modbus (1.13... 99.99)

bit	Name	description	support	version
4	Override off	This is the base signal. This signal overrides the pump (system) command with "OFF" command.	GLANDLESS, GLANDED_SINGLE, GLANDED_MULTI, STRATOS_MAXO	CIF-Module Modbus RTU (3.00... 99.99), IF-Module Modbus Stratos (3.00... 99.99), IF-Module Modbus (3.00... 99.99)
5	Override on	This is the base signal. This signal overrides the pump (system) command with "ON" command.	GLANDLESS, GLANDED_SINGLE, GLANDED_MULTI, PLC_INT	CIF-Module Modbus RTU (3.00... 99.99), IF-Module Modbus Stratos (3.00... 99.99), IF-Module Modbus (3.00... 99.99)
6	FALSE	This is the base signal. This signal represens a static '0' bit, typically for compatibility purpose. For write acces, this bit shall always be '0'.	PLC_INT	CIF-Module Modbus RTU (1.00... 99.99), IF-Module Modbus Stratos (1.13... 99.99), IF-Module Modbus (1.13... 99.99)
7	FALSE	This is the base signal. This signal represens a static '0' bit, typically for compatibility purpose. For write acces, this bit shall always be '0'.	PLC_INT	CIF-Module Modbus RTU (1.00... 99.99), IF-Module Modbus Stratos (1.13... 99.99), IF-Module Modbus (1.13... 99.99)

This is the base signal. This register controls the pump. It can be switched on or off. furthermore, the on/off command can be overridden with min or max values.

6.2.7.3.42 Control Function

property	value
address	42
scope	pump system
function	input value
data type	WORD
Module versions	CIF-Module Modbus RTU (1.00...99.99)

(signal-ID: 56)

value	Name	description	support
1	Gen_Spd	This control mode operates the device with constant speed.	Stratos MAXO; Stratos; IL_E, ...; MVIE, ...;
2	CONST_FREQ	reserved	-
3	Gen_PHdConst	This control mode operates the device with constant differential pressure.	Stratos MAXO; Stratos; IL_E, ...;
4	Gen_PHdVar	This control mode operates the device with a differential pressure which varies with the flow.	Stratos MAXO; Stratos; IL_E, ...;
5	CONST_PRESSURE	This control mode operates the device with constant discharge pressure.	MVIE, ...;
6	TEMP_VARIABLE	This control mode operates the device with a differential pressure which varies with the fluid temperature.	CIF-/IF-Module internal; Stratos;
6	CONST_POWER	reserved	-
7	CONST_HEAD	reserved	-
8	CONST_FLOW	reserved	-
9	Gen_T	This control mode operates the device with constant temperature for generic application.	Stratos MAXO;
10	Gen_TDiff	This control mode operates the device with constant differential temperature for generic application.	Stratos MAXO;
11	CONST_LEV	reserved	-
15	INVALID	Invalid value	CIF-/IF-Module internal;
16	HeatRadiator_PHd	This control mode operates the device with a differential pressure which varies with the flow for heating radiator applications.	Stratos MAXO;
17	HeatRadiator_DA	This control mode operates the device with automatic setpoint adjustment (dynamic adapt) for heating radiator applications.	Stratos MAXO;
18	HeatRadiator_T	This control mode operates the device with constant temperature for heating radiator application.	Stratos MAXO;
19	HeatFloor_PHd	This control mode operates the device with a differential pressure which varies with the flow for floor heating applications.	Stratos MAXO;
20	HeatFloor_DA	This control mode operates the device with automatic setpoint adjustment (dynamic adapt) for floor heating applications.	Stratos MAXO;
21	HeatFloor_T	This control mode operates the device with constant temperature for floor heating application.	Stratos MAXO;
22	HeatCeiling_PHd	This control mode operates the device with constant differential pressure for ceiling heating applications.	Stratos MAXO;
23	HeatCeiling_DA	This control mode operates the device with automatic setpoint adjustment (dynamic adapt) for ceiling heating applications.	Stratos MAXO;
24	HeatCeiling_T	This control mode operates the device with constant temperature for ceiling heating applications.	Stratos MAXO;
25	HeatFan_PHd	This control mode operates the device with a differential pressure which varies with the flow for fan coil heating applications.	Stratos MAXO;
26	HeatFan_DA	This control mode operates the device with automatic setpoint adjustment (dynamic adapt) for fan coil heating applications.	Stratos MAXO;
27	HeatFan_T	This control mode operates the device with constant temperature for fan coil heating applications.	Stratos MAXO;
28	HeatB._T	This control mode operates the device with constant temperature for heating applications with hydraulic separator.	Stratos MAXO;
29	HeatB._TDiff	This control mode operates the device with constant differential temperature for heating applications with hydraulic separator.	Stratos MAXO;
30	HeatB._Acc.Flow	This control mode operates the device with a setpoint depending on the volume flow of other pumps for heating applications with hydraulic separator.	Stratos MAXO;
31	HeatE._T	This control mode operates the device with constant temperature for heating applications with heat exchanger.	Stratos MAXO;
32	HeatE._TDiff	This control mode operates the device with constant differential temperature for heating applications with heat exchanger.	Stratos MAXO;
33	HeatE._Acc.Flow	This control mode operates the device with a setpoint depending on the volume flow of other pumps for heating applications with heat exchanger.	Stratos MAXO;
34	Heat_PHdConst	This control mode operates the device with constant differential pressure for heating applications.	Stratos MAXO;
35	Heat_PHdVar	This control mode operates the device with a differential pressure which varies with the flow for heating applications.	Stratos MAXO;

value	Name	description	support
36	Heat_PHdExt	This control mode operates the device with constant differential pressure for heating applications with external differential pressure sensor.	Stratos MAXO;
37	Heat_DA	This control mode operates the device with automatic setpoint adjustment (dynamic adapt) for heating applications.	Stratos MAXO;
38	Heat_VolFlow	This control mode operates the device with constant volume flow for heating applications.	Stratos MAXO;
39	Heat_Acc.Flow	This control mode operates the device with a setpoint depending on the volume flow of other pumps for heating applications.	Stratos MAXO;
40	Heat_T	This control mode operates the device with constant temperature for heating application.	Stratos MAXO;
41	Heat_TDiff	This control mode operates the device with constant differential temperature for heating application.	Stratos MAXO;
42	Heat_Spd	This control mode operates the device with constant speed for heating applications.	Stratos MAXO;
43	CoolCeiling_PHd	This control mode operates the device with constant differential pressure for ceiling cooling applications.	Stratos MAXO;
44	CoolCeiling_DA	This control mode operates the device with automatic setpoint adjustment (dynamic adapt) for ceiling cooling applications.	Stratos MAXO;
45	CoolCeiling_T	This control mode operates the device with constant temperature for ceiling cooling application.	Stratos MAXO;
46	CoolFloor_PHd	This control mode operates the device with constant differential pressure for floor cooling applications.	Stratos MAXO;
47	CoolFloor_DA	This control mode operates the device with automatic setpoint adjustment (dynamic adapt) for floor cooling applications.	Stratos MAXO;
48	CoolFloor_T	This control mode operates the device with constant temperature mode for floor cooling applications.	Stratos MAXO;
49	CoolFan_PHd	This control mode operates the device with a differential pressure which varies with the flow for fan coil cooling applications.	Stratos MAXO;
50	CoolFan_DA	This control mode operates the device with automatic setpoint adjustment (dynamic adapt) for fan coil cooling applications.	Stratos MAXO;
51	CoolFan_T	This control mode operates the device with constant temperature mode for fan coil cooling application.	Stratos MAXO;
52	CoolB._T	This control mode operates the device with constant temperature for cooling applications with hydraulic separator.	Stratos MAXO;
53	CoolB._TDiff	This control mode operates the device with constant differential temperature for cooling applications with hydraulic separator.	Stratos MAXO;
54	CoolB._Acc.Flow	This control mode operates the device with a setpoint depending on the volume flow of other pumps for cooling applications with hydraulic separator.	Stratos MAXO;
55	CoolE._T	This control mode operates the device with constant temperature mode for cooling application with heat exchanger.	Stratos MAXO;
56	CoolE._TDiff	This control mode operates the device with constant differential temperature for cooling applications with heat exchanger.	Stratos MAXO;
57	CoolE._Acc.Flow	This control mode operates the device with a setpoint depending on the volume flow of other pumps for cooling applications with heat exchanger.	Stratos MAXO;
58	Cool_PHdConst	This control mode operates the device with constant differential pressure for cooling applications.	Stratos MAXO;
59	Cool_PHdVar	This control mode operates the device with a differential pressure which varies with the flow for cooling applications.	Stratos MAXO;
60	Cool_PHdExt	This control mode operates the device with constant differential pressure for cooling application with external differential pressure sensor.	Stratos MAXO;
61	Cool_DA	This control mode operates the device with automatic setpoint adjustment (dynamic adapt) for cooling applications.	Stratos MAXO;
62	Cool_VolFlow	This control mode operates the device with constant volume flow for cooling applications.	Stratos MAXO;
63	Cool_Acc.Flow	This control mode operates the device with a setpoint depending on the volume flow of other pumps for cooling applications.	Stratos MAXO;
64	Cool_T	This control mode operates the device with constant temperature mode for cooling application.	Stratos MAXO;
65	Cool_TDiff	This control mode operates the device with constant differential temperature for cooling application.	Stratos MAXO;

value	Name	description	support
66	Cool_Spd	This control mode operates the motor with constant speed for cooling applications.	Stratos MAXO;
67	San_Circ._T	This control mode operates the device with constant temperature for sanitary hot water circulation.	Stratos MAXO;
68	SanW.Heat._TDiff	This control mode operates the device with constant differential temperature for sanitary hot water application with heat exchanger in the storage tank.	Stratos MAXO;
69	SanL.S._T	reserved	Stratos MAXO;
70	SanL.S._Acc.Flow	reserved	Stratos MAXO;
71	San_PHdConst	This control mode operates the device with constant differential pressure for sanitary hot water applications.	Stratos MAXO;
72	San_PHdVar	This control mode operates the device with a differential pressure which varies with the flow for sanitary hot water applications.	Stratos MAXO;
73	San_PHdExternal	This control mode operates the device with constant differential pressure for sanitary hot water applications with external differential pressure sensor.	Stratos MAXO;
74	San_VolFlow	This control mode operates the device with constant volume flow for sanitary hot water applications.	Stratos MAXO;
75	San_Acc.Flow	This control mode operates the device with a setpoint depending on the volume flow of other pumps for sanitary hot water applications.	Stratos MAXO;
76	San_T	This control mode operates the device with constant temperature for sanitary hot water application.	Stratos MAXO;
77	San_TDiff	This control mode operates the device with constant differential temperature for sanitary hot water application.	Stratos MAXO;
78	San_Spd	This control mode operates the motor with constant speed for sanitary hot water applications.	Stratos MAXO;
79	Gen_PHdExt	This control mode operates the device with constant differential pressure for generic applications with external differential pressure sensor.	Stratos MAXO;
80	Gen_DA	This control mode operates the device with automatic setpoint adjustment (dynamic adapt) for generic applications.	Stratos MAXO;
81	Gen_VolFlow	This control mode operates the device with constant volume flow for generic applications.	Stratos MAXO;
82	Gen_Acc.Flow	This control mode operates the device with a setpoint depending on the volume flow of other pumps for generic applications.	Stratos MAXO;
83	ScndPHdConst	This control mode operates the device with constant differential pressure. A special parameter set which is stored in the device is used.	Stratos MAXO;
84	ScndPHdVar	This control mode operates the device with a differential pressure which varies with the flow. A special parameter set which is stored in the device is used.	Stratos MAXO;
85	ScndFlow	This control mode operates the device with constant volume flow. A special parameter set which is stored in the device is used.	Stratos MAXO;
86	ScndSpd	This control mode operates the motor with constant speed. A special parameter set which is stored in the device is used.	Stratos MAXO;
139	VAR_PRESSURE	This control mode operates the device with a discharge pressure that varies with the flow.	MVIE, ...;
140	Gen_UsrDfd	This control mode operates the device with user configurable PID controller.	Stratos MAXO; IL_E, ...; MVIE, ...;

This is the base signal. This signal represents the control mode for the device. In case a selected mode is not supported, the device will stay in the previously selected mode.

Support reference: Stratos MAXO; Stratos; IL_E, ...; MVIE, ...;

6.2.7.3.44 $\Delta p-c = f(T)$ Regulation Tmin

property	value
address	44
scope	pump system
function	input value / active value
data type	UINT
unit	K
scale	0.1
range low	0
range high	65534
error value	65535
Module versions	CIF-Module Modbus RTU (1.00...99.99)

(signal-ID: 12)

This is the base signal. This Parameter sets the lower temperature limit for temperature dependent pressure control. Below this temperature, the head is always constant. Since this value must always be at least 10 K smaller than Tmax, the value Tmax is always set to 10 K higher than this value with every write access.

Support reference: CIF-/IF-Module internal; Stratos;

6.2.7.3.45 $\Delta p-c = f(T)$ Regulation Tmax

property	value
address	45
scope	pump system
function	input value / active value
data type	UINT
unit	K
scale	0.1
range low	0
range high	65534
error value	65535
Module versions	CIF-Module Modbus RTU (1.00...99.99)

(signal-ID: 11)

This is the base signal. This Parameter sets the upper limit for temperature dependent pressure head control. The head above this temperature is constant. Since this value must always be at least 10 K higher than Tmin, the value Tmin is always set to at least 10 K lower than this value.

Support reference: CIF-/IF-Module internal; Stratos;

6.2.7.3.46 $\Delta p-c = f(T)$ Regulation $\Delta p(T_{min})$

property	value
address	46
scope	pump system
function	input value / active value
data type	UINT
unit	cm H ₂ O
scale	10
range low	0
range high	65534
error value	65535
Module versions	CIF-Module Modbus RTU (1.00...99.99)

(signal-ID: 10)

This is the base signal. This parameter belongs to the operation mode $\Delta p-c = f(T)$. It sets the pressure at and below the temperature Tmin. This value can be higher or lower than the value of Tmax.

Support reference: CIF-/IF-Module internal; Stratos;

6.2.7.3.47 $\Delta p-c = f(T)$ Regulation $\Delta p(T_{max})$

property	value
address	47
scope	pump system
function	input value / active value
data type	UINT
unit	cm H ₂ O
scale	10
range low	0
range high	65534
error value	65535
Module versions	CIF-Module Modbus RTU (1.00...99.99)

(signal-ID: 9)

This is the base signal. This parameter belongs to the operation mode $\Delta p-c = f(T)$. It sets the pressure at and above the temperature T_{max} . This value can be higher or lower than the value of $\Delta p(T_{min})$.

Support reference: CIF-/IF-Module internal; Stratos;

6.2.7.3.300 Bus Command Timer

property	value
address	300
scope	pump system
function	input value / active value
data type	BYTE
range low	1
range high	10
Module versions	CIF-Module Modbus RTU (1.00...99.99)

(signal-ID: 81)

value	Name	description	support
1	OFF	The functionality Bus Command timer is deactivated. The local operation is blocked permanently.	CIF-/IF-Module internal;
2	SET	This value starts a lockout time for the local pump operation. The lockout time may be adjustable.	CIF-/IF-Module internal;
3	ACTIVE	This value indicates that the lockout time is active.	CIF-/IF-Module internal;
4	RESET	This value indicates that the lockout time which was started with the signal "Bus Command Timer SET" has elapsed. Local operation of the device is possible, the write to the device over the communication interface is blocked.	CIF-/IF-Module internal;
5	MANUAL	This value indicates that the local as well as the remote operation is possible. The commands are accepted according "last write wins".	CIF-/IF-Module internal;
6	SET_PRESET	This value starts a lockout time for the local pump operation. After the lockout time has elapsed, PRESET values are used for operation. The lockout time may be adjustable.	CIF-/IF-Module internal;
7	ACTIVE_PRESET	This value indicates that the lockout time which was started with the signal "Bus Command Timer SET_PRESET" is currently active. After the lockout time has elapsed, PRESET values are used for operation.	CIF-/IF-Module internal;
8	RESET_PRESET	This value indicates that the lockout time which was started with the signal "Bus Command Timer SET" has elapsed. Local operation of the device is possible, the write to the device over the communication link is blocked. When this signal becomes active, PRESET values are set once for operation.	CIF-/IF-Module internal;
9	MANUAL_PRESET	This value indicates that the local as well as the remote operation is possible. The commands are accepted according "last write wins". When this signal becomes active, PRESET values are loaded once.	CIF-/IF-Module internal;
10	INVALID	Invalid value	CIF-/IF-Module internal;

This is the base signal. When using an IF-Module the local menu may be disabled by factory setting. The local menu can be enabled permanently by writing the value MANUAL. To use the local menu only when the BAS system fails, repeat writing the value SET at least before the optional Bus Command Timer timeout time (default or fixed value 300 s). The

activation is stored and survives a power on reset. When the mechanism is no longer needed, write OFF to reset to factory setting. If the BAS fails, then the menu can be entered to adjust the settings. E54 may be displayed at the pump. If it is desired to load fallback values when the bus failure event occurs, then use SET_PRESET instead of SET to trigger the bus command timer. This functionality is available with Modbus and BACnet in IF-modules starting with firmware SW > 2.00. For CIF-modules, there is no restriction.

Support reference: CIF-/IF-Module internal;

6.2.7.3.302 temperature reference T1

property	value
address	302
scope	pump system
function	input value
data type	REAL
unit	K
scale	1
Module versions	CIF-Module Modbus RTU (3.00...99.99)

(signal-ID: 9003)

This is the base signal. This signal represents the first fluid reference temperature (T1) of the hydronic circuit for control purposes.

Support reference: Stratos MAXO;

6.2.7.3.304 temperature reference T2

property	value
address	304
scope	pump system
function	input value
data type	REAL
unit	K
scale	1
Module versions	CIF-Module Modbus RTU (3.00...99.99)

(signal-ID: 9004)

This is the base signal. This signal represents the second fluid reference temperature (T2) of the hydronic circuit for control purposes.

Support reference: Stratos MAXO;

6.2.7.3.400 Bus Command Timer Timeout

property	value
address	400
scope	pump system
function	input value / active value
data type	UINT
unit	s
scale	1
range low	0
range high	65534
error value	65535
Module versions	CIF-Module Modbus RTU (3.00...99.99)

(signal-ID: 119)

This is the base signal. This value sets the timeout for the Bus Command Timer.

Support reference: CIF-/IF-Module internal;

6.2.7.3.401 Setpoint Signal Source

property	value
address	401
scope	pump system
function	input value
data type	BYTE
Module versions	CIF-Module Modbus RTU (1.00...99.99)

(signal-ID: 92)

value	Name	description	support
1	IF-Module	Signal source for setpoint: IF-Module	Stratos MAXO; Stratos; IL_E, ...; MVIE, ...;
2	0...10 V	Signal source for setpoint: IN2 mode 0...10 V	CIF-/IF-Module mapped; Stratos; IL_E, ...; MVIE, ...;
3	2...10 V	Signal source for setpoint: IN2 mode 2...10 V	CIF-/IF-Module mapped; IL_E, ...; MVIE, ...;
4	0...20 mA	Signal source for setpoint: IN2 mode 0...20 mA	CIF-/IF-Module mapped; IL_E, ...; MVIE, ...;
5	4...20 mA	Signal source for setpoint: IN2 mode 4...20 mA	CIF-/IF-Module mapped; IL_E, ...; MVIE, ...;
6	Internal	Signal source for setpoint: internal	Stratos MAXO;
7	EXT 1	Signal source for setpoint: EXT 1	Stratos MAXO;
8	EXT 2	Signal source for setpoint: EXT 2	Stratos MAXO;
9	INVALID	Invalid value	CIF-/IF-Module internal;

This is the base signal. This signal represents the source for the setpoint for the current control function.

Support reference: Stratos MAXO; Stratos; IL_E, ...; MVIE, ...;

6.2.7.3.402 duty point (rel.) preset

property	value
address	402
scope	pump system
function	input value / active value
data type	INT
unit	%
scale	0.5
range low	-32768
range high	32766
Module versions	CIF-Module Modbus RTU (1.00...99.99)

(signal-ID: 1)

This incorporates a preset or fallback function for the following signal. It contains the relative duty point of the device. The valid range is not necessarily 0...100 %. a duty point of 0 % is not necessarily linked to the OFF state of the device.

Support reference: CIF-/IF-Module mapped; Stratos; IL_E, ...; MVIE, ...;

6.2.7.3.403 Control Function preset

property	value
address	403
scope	pump system
function	input value / active value
data type	WORD
range low	0
range high	140
Module versions	CIF-Module Modbus RTU (1.00...99.99)

(signal-ID: 56)

value	Name	description	support
1	Gen_Spd	This control mode operates the device with constant speed.	Stratos MAXO; Stratos; IL_E, ...; MVIE, ...;
2	CONST_FREQ	reserved	-
3	Gen_PHdConst	This control mode operates the device with constant differential pressure.	Stratos MAXO; Stratos; IL_E, ...;
4	Gen_PHdVar	This control mode operates the device with a differential pressure which varies with the flow.	Stratos MAXO; Stratos; IL_E, ...;
5	CONST_PRESSURE	This control mode operates the device with constant discharge pressure.	MVIE, ...;
6	TEMP_VARIABLE	This control mode operates the device with a differential pressure which varies with the fluid temperature.	CIF-/IF-Module internal; Stratos;
6	CONST_POWER	reserved	-
7	CONST_HEAD	reserved	-
8	CONST_FLOW	reserved	-
9	Gen_T	This control mode operates the device with constant temperature for generic application.	Stratos MAXO;
10	Gen_TDiff	This control mode operates the device with constant differential temperature for generic application.	Stratos MAXO;
11	CONST_LEV	reserved	-
15	INVALID	Invalid value	CIF-/IF-Module internal;
16	HeatRadiator_PHd	This control mode operates the device with a differential pressure which varies with the flow for heating radiator applications.	Stratos MAXO;
17	HeatRadiator_DA	This control mode operates the device with automatic setpoint adjustment (dynamic adapt) for heating radiator applications.	Stratos MAXO;
18	HeatRadiator_T	This control mode operates the device with constant temperature for heating radiator application.	Stratos MAXO;
19	HeatFloor_PHd	This control mode operates the device with a differential pressure which varies with the flow for floor heating applications.	Stratos MAXO;
20	HeatFloor_DA	This control mode operates the device with automatic setpoint adjustment (dynamic adapt) for floor heating applications.	Stratos MAXO;
21	HeatFloor_T	This control mode operates the device with constant temperature for floor heating application.	Stratos MAXO;
22	HeatCeiling_PHd	This control mode operates the device with constant differential pressure for ceiling heating applications.	Stratos MAXO;
23	HeatCeiling_DA	This control mode operates the device with automatic setpoint adjustment (dynamic adapt) for ceiling heating applications.	Stratos MAXO;
24	HeatCeiling_T	This control mode operates the device with constant temperature for ceiling heating applications.	Stratos MAXO;
25	HeatFan_PHd	This control mode operates the device with a differential pressure which varies with the flow for fan coil heating applications.	Stratos MAXO;
26	HeatFan_DA	This control mode operates the device with automatic setpoint adjustment (dynamic adapt) for fan coil heating applications.	Stratos MAXO;
27	HeatFan_T	This control mode operates the device with constant temperature for fan coil heating applications.	Stratos MAXO;
28	HeatB._T	This control mode operates the device with constant temperature for heating applications with hydraulic separator.	Stratos MAXO;
29	HeatB._TDiff	This control mode operates the device with constant differential temperature for heating applications with hydraulic separator.	Stratos MAXO;
30	HeatB._Acc.Flow	This control mode operates the device with a setpoint depending on the volume flow of other pumps for heating applications with hydraulic separator.	Stratos MAXO;
31	HeatE._T	This control mode operates the device with constant temperature for heating applications with heat exchanger.	Stratos MAXO;
32	HeatE._TDiff	This control mode operates the device with constant differential temperature for heating applications with heat exchanger.	Stratos MAXO;
33	HeatE._Acc.Flow	This control mode operates the device with a setpoint depending on the volume flow of other pumps for heating applications with heat exchanger.	Stratos MAXO;
34	Heat_PHdConst	This control mode operates the device with constant differential pressure for heating applications.	Stratos MAXO;
35	Heat_PHdVar	This control mode operates the device with a differential pressure which varies with the flow for heating applications.	Stratos MAXO;

value	Name	description	support
36	Heat_PHdExt	This control mode operates the device with constant differential pressure for heating applications with external differential pressure sensor.	Stratos MAXO;
37	Heat_DA	This control mode operates the device with automatic setpoint adjustment (dynamic adapt) for heating applications.	Stratos MAXO;
38	Heat_VolFlow	This control mode operates the device with constant volume flow for heating applications.	Stratos MAXO;
39	Heat_Acc.Flow	This control mode operates the device with a setpoint depending on the volume flow of other pumps for heating applications.	Stratos MAXO;
40	Heat_T	This control mode operates the device with constant temperature for heating application.	Stratos MAXO;
41	Heat_TDiff	This control mode operates the device with constant differential temperature for heating application.	Stratos MAXO;
42	Heat_Spd	This control mode operates the device with constant speed for heating applications.	Stratos MAXO;
43	CoolCeiling_PHd	This control mode operates the device with constant differential pressure for ceiling cooling applications.	Stratos MAXO;
44	CoolCeiling_DA	This control mode operates the device with automatic setpoint adjustment (dynamic adapt) for ceiling cooling applications.	Stratos MAXO;
45	CoolCeiling_T	This control mode operates the device with constant temperature for ceiling cooling application.	Stratos MAXO;
46	CoolFloor_PHd	This control mode operates the device with constant differential pressure for floor cooling applications.	Stratos MAXO;
47	CoolFloor_DA	This control mode operates the device with automatic setpoint adjustment (dynamic adapt) for floor cooling applications.	Stratos MAXO;
48	CoolFloor_T	This control mode operates the device with constant temperature mode for floor cooling applications.	Stratos MAXO;
49	CoolFan_PHd	This control mode operates the device with a differential pressure which varies with the flow for fan coil cooling applications.	Stratos MAXO;
50	CoolFan_DA	This control mode operates the device with automatic setpoint adjustment (dynamic adapt) for fan coil cooling applications.	Stratos MAXO;
51	CoolFan_T	This control mode operates the device with constant temperature mode for fan coil cooling application.	Stratos MAXO;
52	CoolB._T	This control mode operates the device with constant temperature for cooling applications with hydraulic separator.	Stratos MAXO;
53	CoolB._TDiff	This control mode operates the device with constant differential temperature for cooling applications with hydraulic separator.	Stratos MAXO;
54	CoolB._Acc.Flow	This control mode operates the device with a setpoint depending on the volume flow of other pumps for cooling applications with hydraulic separator.	Stratos MAXO;
55	CoolE._T	This control mode operates the device with constant temperature mode for cooling application with heat exchanger.	Stratos MAXO;
56	CoolE._TDiff	This control mode operates the device with constant differential temperature for cooling applications with heat exchanger.	Stratos MAXO;
57	CoolE._Acc.Flow	This control mode operates the device with a setpoint depending on the volume flow of other pumps for cooling applications with heat exchanger.	Stratos MAXO;
58	Cool_PHdConst	This control mode operates the device with constant differential pressure for cooling applications.	Stratos MAXO;
59	Cool_PHdVar	This control mode operates the device with a differential pressure which varies with the flow for cooling applications.	Stratos MAXO;
60	Cool_PHdExt	This control mode operates the device with constant differential pressure for cooling application with external differential pressure sensor.	Stratos MAXO;
61	Cool_DA	This control mode operates the device with automatic setpoint adjustment (dynamic adapt) for cooling applications.	Stratos MAXO;
62	Cool_VolFlow	This control mode operates the device with constant volume flow for cooling applications.	Stratos MAXO;
63	Cool_Acc.Flow	This control mode operates the device with a setpoint depending on the volume flow of other pumps for cooling applications.	Stratos MAXO;
64	Cool_T	This control mode operates the device with constant temperature mode for cooling application.	Stratos MAXO;
65	Cool_TDiff	This control mode operates the device with constant differential temperature for cooling application.	Stratos MAXO;

value	Name	description	support
66	Cool_Spd	This control mode operates the motor with constant speed for cooling applications.	Stratos MAXO;
67	San_Circ._T	This control mode operates the device with constant temperature for sanitary hot water circulation.	Stratos MAXO;
68	SanW.Heat._TDiff	This control mode operates the device with constant differential temperature for sanitary hot water application with heat exchanger in the storage tank.	Stratos MAXO;
69	SanL.S._T	reserved	Stratos MAXO;
70	SanL.S._Acc.Flow	reserved	Stratos MAXO;
71	San_PHdConst	This control mode operates the device with constant differential pressure for sanitary hot water applications.	Stratos MAXO;
72	San_PHdVar	This control mode operates the device with a differential pressure which varies with the flow for sanitary hot water applications.	Stratos MAXO;
73	San_PHdExternal	This control mode operates the device with constant differential pressure for sanitary hot water applications with external differential pressure sensor.	Stratos MAXO;
74	San_VolFlow	This control mode operates the device with constant volume flow for sanitary hot water applications.	Stratos MAXO;
75	San_Acc.Flow	This control mode operates the device with a setpoint depending on the volume flow of other pumps for sanitary hot water applications.	Stratos MAXO;
76	San_T	This control mode operates the device with constant temperature for sanitary hot water application.	Stratos MAXO;
77	San_TDiff	This control mode operates the device with constant differential temperature for sanitary hot water application.	Stratos MAXO;
78	San_Spd	This control mode operates the motor with constant speed for sanitary hot water applications.	Stratos MAXO;
79	Gen_PHdExt	This control mode operates the device with constant differential pressure for generic applications with external differential pressure sensor.	Stratos MAXO;
80	Gen_DA	This control mode operates the device with automatic setpoint adjustment (dynamic adapt) for generic applications.	Stratos MAXO;
81	Gen_VolFlow	This control mode operates the device with constant volume flow for generic applications.	Stratos MAXO;
82	Gen_Acc.Flow	This control mode operates the device with a setpoint depending on the volume flow of other pumps for generic applications.	Stratos MAXO;
83	ScndPHdConst	This control mode operates the device with constant differential pressure. A special parameter set which is stored in the device is used.	Stratos MAXO;
84	ScndPHdVar	This control mode operates the device with a differential pressure which varies with the flow. A special parameter set which is stored in the device is used.	Stratos MAXO;
85	ScndFlow	This control mode operates the device with constant volume flow. A special parameter set which is stored in the device is used.	Stratos MAXO;
86	ScndSpd	This control mode operates the motor with constant speed. A special parameter set which is stored in the device is used.	Stratos MAXO;
139	VAR_PRESSURE	This control mode operates the device with a discharge pressure that varies with the flow.	MVIE, ...;
140	Gen_UsrDfd	This control mode operates the device with user configurable PID controller.	Stratos MAXO; IL_E, ...; MVIE, ...;

This incorporates a preset or fallback function for the following signal. This signal represents the control mode for the device. In case a selected mode is not supported, the device will stay in the previously selected mode.

Support reference: Stratos MAXO; Stratos; IL_E, ...; MVIE, ...;

6.2.7.3.404 Pump Command preset

property	value
address	404
scope	pump system
function	input value
data type	BYTE
Module versions	CIF-Module Modbus RTU (1.00...99.99)
(signal-ID:)	

bit	Name	description	support	version
0	Pump on preset	This incorporates a preset or fallback function for the following signal. This signal represents the normal "ON" command. This signal is effective, if no override functions are active.	GLANDLESS, GLANDED_SINGLE, GLANDED_MULTI, STRATOS_MAXO	CIF-Module Modbus RTU (1.00...99.99), IF-Module Modbus Stratos (3.00...99.99), IF-Module Modbus (3.00...99.99)

This is the base signal.

6.2.7.3.405 Setpoint Signal Source preset

property	value
address	405
scope	pump system
function	input value / active value
data type	BYTE
Module versions	CIF-Module Modbus RTU (1.00...99.99)

(signal-ID: 92)

value	Name	description	support
1	IF-Module	Signal source for setpoint: IF-Module	Stratos MAXO; Stratos; IL_E, ...; MVIE, ...;
2	0...10 V	Signal source for setpoint: IN2 mode 0...10 V	CIF-/IF-Module mapped; Stratos; IL_E, ...; MVIE, ...;
3	2...10 V	Signal source for setpoint: IN2 mode 2...10 V	CIF-/IF-Module mapped; IL_E, ...; MVIE, ...;
4	0...20 mA	Signal source for setpoint: IN2 mode 0...20 mA	CIF-/IF-Module mapped; IL_E, ...; MVIE, ...;
5	4...20 mA	Signal source for setpoint: IN2 mode 4...20 mA	CIF-/IF-Module mapped; IL_E, ...; MVIE, ...;
6	Internal	Signal source for setpoint: internal	Stratos MAXO;
7	EXT 1	Signal source for setpoint: EXT 1	Stratos MAXO;
8	EXT 2	Signal source for setpoint: EXT 2	Stratos MAXO;
9	INVALID	Invalid value	CIF-/IF-Module internal;

This incorporates a preset or fallback function for the following signal. This signal represents the source for the setpoint for the current control function.

Support reference: Stratos MAXO; Stratos; IL_E, ...; MVIE, ...;

6.2.7.3.408 PID Kp

property	value
address	408
scope	pump system
function	input value / active value
data type	INT
unit	-
scale	0.01
range low	-32768
range high	32766
error value	32767
Module versions	CIF-Module Modbus RTU (1.00...99.99)

(signal-ID: 19)

This is the base signal. The parameter Kp controls the gain of the PID closed loop controller.

Support reference: Stratos MAXO; IL_E, ...; MVIE, ...;

6.2.7.3.409 PID Ti

property	value
address	409
scope	pump system
function	input value / active value
data type	INT
unit	s
scale	0.01
range low	-32768
range high	32766
error value	32767
Module versions	CIF-Module Modbus RTU (1.00...99.99)

(signal-ID: 21)

This is the base signal. The parameter Ti represent the integral time for the PID closed loop controller.

Support reference: CIF-/IF-Module mapped; IL_E, ...; MVIE, ...;

6.2.7.3.410 PID Td

property	value
address	410
scope	pump system
function	input value / active value
data type	INT
unit	s
scale	0.01
range low	-32768
range high	32766
error value	32767
Module versions	CIF-Module Modbus RTU (1.00...99.99)

(signal-ID: 20)

This is the base signal. The Td parameter represents the derivative time for the PID closed loop controller.

Support reference: CIF-/IF-Module mapped; IL_E, ...; MVIE, ...;

6.2.7.4 Input Registers

address	name
1	Pressure
2	Flow (estimated)
3	Energy Consumption
4	power input
5	Operation Time
6	Electrical Current
7	Speed
8	temperature fluid @ device
9	Operating Hours DP
10	Control Function
16	Pump Module
17	Pump Type
18	Speed max-pres-value
19	Speed min-pres-value
20	Pressure Max Δp -c
21	Pressure Min Δp -c
22	Pressure Max Δp -v
23	Pressure Min Δp -v
24	Flow (estimated) max-pres-value
25	Flow (estimated) min-pres-value
26	Supported Errors
27	Supported Service Messages
28	power input max-pres-value
35	Service Message
36	Error Type
37	Error Message
38	Pump Status
39	State Diagnostics
65	Pressure
66	Flow (estimated)
67	Energy Consumption
68	power input
69	Operation Time
70	Electrical Current
71	Speed
80	Pump Module (Slave)
81	Pump Type (Slave)
100	Error Type (Slave)
102	Pump Status (Slave)
200	duty point (rel.)
202	duty point (rel.) maximum-output
204	duty point (rel.) minimum-output
206	duty point 100 % value
208	duty point (rel.) units
210	Setpoint Signal Source
300	power heating
302	power refrigeration
304	Energy heating resettable
308	Energy refrigeration resettable
312	Energy heating total
314	Energy refrigeration total
316	temperature fluid forward
318	temperature fluid return
320	Voltage Input
324	Analog In 1 Measured Value
326	Analog In 2 Measured Value
400	duty point (rel.)
402	Effective Pump Command
404	Operation Status
500	Heartbeat Count

address	name
502	System Time
700	Application Version
702	Vendor ID
740	pump type CAN
750	pump type CAN
901	User Trouble Code
940	Warning/Error Message
950	Warning/Error Message

6.2.7.4.1 Pressure

property	value
address	1
scope	pump system
function	output value
data type	UINT
unit	cm H ₂ O
scale	10
range low	0
range high	65534
error value	65535
Module versions	CIF-Module Modbus RTU (1.00...99.99)

(signal-ID: 32)

This is the base signal. This signal represents the current pressure at the pump system. Depending on the sensor arrangement, this value is an absolute or a differential pressure. It can also be a signal of a remote sensor. Some pump type operate without a pressure sensor. In this case, the value is calculated.

Support reference: Stratos MAXO; Stratos; IL_E, ...; MVIE, ...;

6.2.7.4.2 Flow (estimated)

property	value
address	2
scope	pump system
function	output value
data type	UINT
unit	m ³ /h
scale	0.1
range low	0
range high	9998
error value	9999
Module versions	CIF-Module Modbus RTU (1.00...99.99)

(signal-ID: 29)

This is the base signal. This signal represents the (calculated) flow. Calculated values are not suitable for closed loop control applications due to restricted availability and precision over the range of operation.

Support reference: Stratos MAXO; Stratos; IL_E, ...;

6.2.7.4.3 Energy Consumption

property	value
address	3
scope	pump system
function	output value
data type	UINT
unit	kWh
scale	1
range low	0
range high	65534
error value	65535
Module versions	CIF-Module Modbus RTU (1.00...99.99)

(signal-ID: 26)

This is the base signal. This value represent the totally consumed electrical energy. This value is suitable for an energy performance evaluation.

Support reference: Stratos MAXO; Stratos; IL_E, ...; MVIE, ...;

6.2.7.4.4 power input

property	value
address	4
scope	pump system
function	output value
data type	UINT
unit	W
scale	1
range low	0
range high	65534
error value	65535
Module versions	CIF-Module Modbus RTU (1.00...99.99)

(signal-ID: 4)

This is the base signal. This signal represents the current electrical input power.

Support reference: Stratos MAXO; Stratos; IL_E, ...; MVIE, ...;

6.2.7.4.5 Operation Time

property	value
address	5
scope	master pump
function	output value
data type	UINT
unit	h
scale	10
range low	0
range high	65534
error value	65535
Module versions	CIF-Module Modbus RTU (1.00...99.99)

(signal-ID: 139)

This is the base signal. This value represents the total time where the device was running (motor turning).

Support reference: Stratos MAXO; Stratos; IL_E, ...; MVIE, ...;

6.2.7.4.6 Electrical Current

property	value
address	6
scope	master pump
function	output value
data type	UINT
unit	A
scale	0.1
range low	0
range high	65534
error value	65535
Module versions	CIF-Module Modbus RTU (1.00...99.99)

(signal-ID: 3)

This is the base signal. This signal represents the electrical input current.

Support reference: Stratos; IL_E, ... MVIE, ...(0.55...7.5 kW);

6.2.7.4.7 Speed

property	value
address	7
scope	master pump
function	output value
data type	UINT
unit	1/min
scale	1
range low	0
range high	65534
error value	65535
Module versions	CIF-Module Modbus RTU (1.00...99.99)

(signal-ID: 31)

This is the base signal. This signal shows the rotational speed of the pump.

Support reference: Stratos MAXO; Stratos; IL_E, ...; MVIE, ...;

6.2.7.4.8 temperature fluid @ device

property	value
address	8
scope	pump system
function	output value
data type	UINT
unit	K
scale	0.1
range low	0
range high	65534
error value	65535
Module versions	CIF-Module Modbus RTU (1.00...99.99)

(signal-ID: 5)

This is the base signal. This signal shows the measurement value of the fluid temperature sensor. It can also be a remote sensor signal.

Support reference: Stratos MAXO; Stratos;

6.2.7.4.9 Operating Hours DP

property	value
address	9
scope	pump system
function	output value
data type	UINT
unit	h
scale	10
range low	0
range high	65534
error value	65535
Module versions	CIF-Module Modbus RTU (1.00...99.99)

(signal-ID: 139)

This is the base signal. This value represents the total time where the device was running (motor turning). This Input register returns the operating time of the double pump system.

Support reference: Stratos MAXO; Stratos; IL_E, ...; MVIE, ...;

6.2.7.4.10 Control Function

property	value
address	10
scope	pump system
function	active value
data type	WORD
Module versions	CIF-Module Modbus RTU (1.00...99.99)

(signal-ID: 56)

value	Name	description	support
1	Gen_Spd	This control mode operates the device with constant speed.	Stratos MAXO; Stratos; IL_E, ...; MVIE, ...;
2	CONST_FREQ	reserved	-
3	Gen_PHdConst	This control mode operates the device with constant differential pressure.	Stratos MAXO; Stratos; IL_E, ...;
4	Gen_PHdVar	This control mode operates the device with a differential pressure which varies with the flow.	Stratos MAXO; Stratos; IL_E, ...;
5	CONST_PRESSURE	This control mode operates the device with constant discharge pressure.	MVIE, ...;
6	TEMP_VARIABLE	This control mode operates the device with a differential pressure which varies with the fluid temperature.	CIF-/IF-Module internal; Stratos;
6	CONST_POWER	reserved	-
7	CONST_HEAD	reserved	-
8	CONST_FLOW	reserved	-
9	Gen_T	This control mode operates the device with constant temperature for generic application.	Stratos MAXO;
10	Gen_TDiff	This control mode operates the device with constant differential temperature for generic application.	Stratos MAXO;
11	CONST_LEV	reserved	-
15	INVALID	Invalid value	CIF-/IF-Module internal;
16	HeatRadiator_PHd	This control mode operates the device with a differential pressure which varies with the flow for heating radiator applications.	Stratos MAXO;
17	HeatRadiator_DA	This control mode operates the device with automatic setpoint adjustment (dynamic adapt) for heating radiator applications.	Stratos MAXO;
18	HeatRadiator_T	This control mode operates the device with constant temperature for heating radiator application.	Stratos MAXO;
19	HeatFloor_PHd	This control mode operates the device with a differential pressure which varies with the flow for floor heating applications.	Stratos MAXO;
20	HeatFloor_DA	This control mode operates the device with automatic setpoint adjustment (dynamic adapt) for floor heating applications.	Stratos MAXO;
21	HeatFloor_T	This control mode operates the device with constant temperature for floor heating application.	Stratos MAXO;
22	HeatCeiling_PHd	This control mode operates the device with constant differential pressure for ceiling heating applications.	Stratos MAXO;
23	HeatCeiling_DA	This control mode operates the device with automatic setpoint adjustment (dynamic adapt) for ceiling heating applications.	Stratos MAXO;
24	HeatCeiling_T	This control mode operates the device with constant temperature for ceiling heating applications.	Stratos MAXO;
25	HeatFan_PHd	This control mode operates the device with a differential pressure which varies with the flow for fan coil heating applications.	Stratos MAXO;
26	HeatFan_DA	This control mode operates the device with automatic setpoint adjustment (dynamic adapt) for fan coil heating applications.	Stratos MAXO;
27	HeatFan_T	This control mode operates the device with constant temperature for fan coil heating applications.	Stratos MAXO;
28	HeatB._T	This control mode operates the device with constant temperature for heating applications with hydraulic separator.	Stratos MAXO;
29	HeatB._TDiff	This control mode operates the device with constant differential temperature for heating applications with hydraulic separator.	Stratos MAXO;
30	HeatB._Acc.Flow	This control mode operates the device with a setpoint depending on the volume flow of other pumps for heating applications with hydraulic separator.	Stratos MAXO;
31	HeatE._T	This control mode operates the device with constant temperature for heating applications with heat exchanger.	Stratos MAXO;
32	HeatE._TDiff	This control mode operates the device with constant differential temperature for heating applications with heat exchanger.	Stratos MAXO;
33	HeatE._Acc.Flow	This control mode operates the device with a setpoint depending on the volume flow of other pumps for heating applications with heat exchanger.	Stratos MAXO;
34	Heat_PHdConst	This control mode operates the device with constant differential pressure for heating applications.	Stratos MAXO;
35	Heat_PHdVar	This control mode operates the device with a differential pressure which varies with the flow for heating applications.	Stratos MAXO;

value	Name	description	support
36	Heat_PHdExt	This control mode operates the device with constant differential pressure for heating applications with external differential pressure sensor.	Stratos MAXO;
37	Heat_DA	This control mode operates the device with automatic setpoint adjustment (dynamic adapt) for heating applications.	Stratos MAXO;
38	Heat_VolFlow	This control mode operates the device with constant volume flow for heating applications.	Stratos MAXO;
39	Heat_Acc.Flow	This control mode operates the device with a setpoint depending on the volume flow of other pumps for heating applications.	Stratos MAXO;
40	Heat_T	This control mode operates the device with constant temperature for heating application.	Stratos MAXO;
41	Heat_TDiff	This control mode operates the device with constant differential temperature for heating application.	Stratos MAXO;
42	Heat_Spd	This control mode operates the device with constant speed for heating applications.	Stratos MAXO;
43	CoolCeiling_PHd	This control mode operates the device with constant differential pressure for ceiling cooling applications.	Stratos MAXO;
44	CoolCeiling_DA	This control mode operates the device with automatic setpoint adjustment (dynamic adapt) for ceiling cooling applications.	Stratos MAXO;
45	CoolCeiling_T	This control mode operates the device with constant temperature for ceiling cooling application.	Stratos MAXO;
46	CoolFloor_PHd	This control mode operates the device with constant differential pressure for floor cooling applications.	Stratos MAXO;
47	CoolFloor_DA	This control mode operates the device with automatic setpoint adjustment (dynamic adapt) for floor cooling applications.	Stratos MAXO;
48	CoolFloor_T	This control mode operates the device with constant temperature mode for floor cooling applications.	Stratos MAXO;
49	CoolFan_PHd	This control mode operates the device with a differential pressure which varies with the flow for fan coil cooling applications.	Stratos MAXO;
50	CoolFan_DA	This control mode operates the device with automatic setpoint adjustment (dynamic adapt) for fan coil cooling applications.	Stratos MAXO;
51	CoolFan_T	This control mode operates the device with constant temperature mode for fan coil cooling application.	Stratos MAXO;
52	CoolB._T	This control mode operates the device with constant temperature for cooling applications with hydraulic separator.	Stratos MAXO;
53	CoolB._TDiff	This control mode operates the device with constant differential temperature for cooling applications with hydraulic separator.	Stratos MAXO;
54	CoolB._Acc.Flow	This control mode operates the device with a setpoint depending on the volume flow of other pumps for cooling applications with hydraulic separator.	Stratos MAXO;
55	CoolE._T	This control mode operates the device with constant temperature mode for cooling application with heat exchanger.	Stratos MAXO;
56	CoolE._TDiff	This control mode operates the device with constant differential temperature for cooling applications with heat exchanger.	Stratos MAXO;
57	CoolE._Acc.Flow	This control mode operates the device with a setpoint depending on the volume flow of other pumps for cooling applications with heat exchanger.	Stratos MAXO;
58	Cool_PHdConst	This control mode operates the device with constant differential pressure for cooling applications.	Stratos MAXO;
59	Cool_PHdVar	This control mode operates the device with a differential pressure which varies with the flow for cooling applications.	Stratos MAXO;
60	Cool_PHdExt	This control mode operates the device with constant differential pressure for cooling application with external differential pressure sensor.	Stratos MAXO;
61	Cool_DA	This control mode operates the device with automatic setpoint adjustment (dynamic adapt) for cooling applications.	Stratos MAXO;
62	Cool_VolFlow	This control mode operates the device with constant volume flow for cooling applications.	Stratos MAXO;
63	Cool_Acc.Flow	This control mode operates the device with a setpoint depending on the volume flow of other pumps for cooling applications.	Stratos MAXO;
64	Cool_T	This control mode operates the device with constant temperature mode for cooling application.	Stratos MAXO;
65	Cool_TDiff	This control mode operates the device with constant differential temperature for cooling application.	Stratos MAXO;

value	Name	description	support
66	Cool_Spd	This control mode operates the motor with constant speed for cooling applications.	Stratos MAXO;
67	San_Circ._T	This control mode operates the device with constant temperature for sanitary hot water circulation.	Stratos MAXO;
68	SanW.Heat._TDiff	This control mode operates the device with constant differential temperature for sanitary hot water application with heat exchanger in the storage tank.	Stratos MAXO;
69	SanL.S._T	reserved	Stratos MAXO;
70	SanL.S._Acc.Flow	reserved	Stratos MAXO;
71	San_PHdConst	This control mode operates the device with constant differential pressure for sanitary hot water applications.	Stratos MAXO;
72	San_PHdVar	This control mode operates the device with a differential pressure which varies with the flow for sanitary hot water applications.	Stratos MAXO;
73	San_PHdExternal	This control mode operates the device with constant differential pressure for sanitary hot water applications with external differential pressure sensor.	Stratos MAXO;
74	San_VolFlow	This control mode operates the device with constant volume flow for sanitary hot water applications.	Stratos MAXO;
75	San_Acc.Flow	This control mode operates the device with a setpoint depending on the volume flow of other pumps for sanitary hot water applications.	Stratos MAXO;
76	San_T	This control mode operates the device with constant temperature for sanitary hot water application.	Stratos MAXO;
77	San_TDiff	This control mode operates the device with constant differential temperature for sanitary hot water application.	Stratos MAXO;
78	San_Spd	This control mode operates the motor with constant speed for sanitary hot water applications.	Stratos MAXO;
79	Gen_PHdExt	This control mode operates the device with constant differential pressure for generic applications with external differential pressure sensor.	Stratos MAXO;
80	Gen_DA	This control mode operates the device with automatic setpoint adjustment (dynamic adapt) for generic applications.	Stratos MAXO;
81	Gen_VolFlow	This control mode operates the device with constant volume flow for generic applications.	Stratos MAXO;
82	Gen_Acc.Flow	This control mode operates the device with a setpoint depending on the volume flow of other pumps for generic applications.	Stratos MAXO;
83	ScndPHdConst	This control mode operates the device with constant differential pressure. A special parameter set which is stored in the device is used.	Stratos MAXO;
84	ScndPHdVar	This control mode operates the device with a differential pressure which varies with the flow. A special parameter set which is stored in the device is used.	Stratos MAXO;
85	ScndFlow	This control mode operates the device with constant volume flow. A special parameter set which is stored in the device is used.	Stratos MAXO;
86	ScndSpd	This control mode operates the motor with constant speed. A special parameter set which is stored in the device is used.	Stratos MAXO;
139	VAR_PRESSURE	This control mode operates the device with a discharge pressure that varies with the flow.	MVIE, ...;
140	Gen_UsrDfd	This control mode operates the device with user configurable PID controller.	Stratos MAXO; IL_E, ...; MVIE, ...;

This is the base signal. This signal represents the control mode for the device. In case a selected mode is not supported, the device will stay in the previously selected mode.

Support reference: Stratos MAXO; Stratos; IL_E, ...; MVIE, ...;

6.2.7.4.16 Pump Module

property	value
address	16
scope	pump system
function	output value
data type	WORD
Module versions	CIF-Module Modbus RTU (1.00...99.99)
(signal-ID:)	

bit	Name	description	support	version
0	TRUE	This is the base signal. This signal represents a static '1' bit, typically for compatibility purpose. For write acces, this bit shall always be '1'.	PLC_INT	CIF-Module Modbus RTU (1.00...99.99), IF-Module Modbus Stratos (1.13...99.99), IF-Module Modbus (1.13...99.99)

This is the base signal. This register returns if the pump module is controlled by a frequency converter or not.

6.2.7.4.17 Pump Type

property	value
address	17
scope	pump system
function	output value
data type	BYTE
Module versions	CIF-Module Modbus RTU (1.00...99.99)

(signal-ID: 65)

value	Name	description	support
254	EXTENDED	This value is valid, but not covered by this enumeration.	CIF-/IF-Module internal;
255	INVALID	This value is invalid (error value).	CIF-/IF-Module internal;

This is the base signal. This signal shows the pump type in PLR notation. This signal is presented for compatibility reason. If this pump has no PLR pump type, the value EXTENDED will be returned.

Support reference: CIF-/IF-Module mapped;

6.2.7.4.18 Speed max-pres-value

property	value
address	18
scope	pump system
function	active value
data type	UINT
unit	1/min
scale	1
range low	0
range high	65534
error value	65535
Module versions	CIF-Module Modbus RTU (1.00...99.99)

(signal-ID: 31)

This is the base signal. This signal shows the rotational speed of the pump.

Support reference: Stratos MAXO; Stratos; IL_E, ...; MVIE, ...;

6.2.7.4.19 Speed min-pres-value

property	value
address	19
scope	pump system
function	active value
data type	UINT
unit	1/min
scale	1
range low	0
range high	65534
error value	65535
Module versions	CIF-Module Modbus RTU (1.00...99.99)

(signal-ID: 31)

This is the base signal. This signal shows the rotational speed of the pump.

Support reference: Stratos MAXO; Stratos; IL_E, ...; MVIE, ...;

6.2.7.4.20 Pressure Max Δp -c

property	value
address	20
scope	pump system
function	active value
data type	UINT
unit	cm H ₂ O
scale	10
range low	0
range high	65534
error value	65535
Module versions	CIF-Module Modbus RTU (1.00...99.99)

(signal-ID: 7)

This is the base signal. This signal shows the maximum possible pressure setpoint for the operation mode Δ p-c. It can be used to scale a setpoint in percent back to the physical unit. For multistage pumps, this value is not the maximum head of the pump, but the measurement range of the sensor.

Support reference: Stratos MAXO; Stratos; IL_E, ...; MVIE, ...;

6.2.7.4.21 Pressure Min Δ p-c

property	value
address	21
scope	pump system
function	active value
data type	UINT
unit	cm H ₂ O
scale	10
range low	0
range high	65534
error value	65535
Module versions	CIF-Module Modbus RTU (1.00...99.99)

(signal-ID: 16)

This is the base signal. This signal shows the minimum possible pressure setpoint in the operation mode Δ p-c.

Support reference: Stratos MAXO; Stratos; IL_E, ...; MVIE, ...;

6.2.7.4.22 Pressure Max Δ p-v

property	value
address	22
scope	pump system
function	active value
data type	UINT
unit	cm H ₂ O
scale	10
range low	0
range high	65534
error value	65535
Module versions	CIF-Module Modbus RTU (1.00...99.99)

(signal-ID: 13)

This is the base signal. This signal shows the maximum possible pressure setpoint for the operation mode Δ p-v. It can be used to scale a setpoint in percent back to the physical unit. For multistage pumps, this value is not the maximum head of the pump, but the measurement range of the sensor.

Support reference: Stratos MAXO; Stratos; IL_E, ...;

6.2.7.4.23 Pressure Min Δ p-v

property	value
address	23
scope	pump system
function	active value
data type	UINT
unit	cm H ₂ O
scale	10
range low	0
range high	65534
error value	65535
Module versions	CIF-Module Modbus RTU (1.00...99.99)

(signal-ID: 17)

This is the base signal. This signal shows the minimum possible pressure setpoint in the operation mode Δ p-v.

Support reference: Stratos MAXO; Stratos; IL_E, ...;

6.2.7.4.24 Flow (estimated) max-pres-value

property	value
address	24
scope	pump system
function	output value
data type	UINT
unit	m ³ /h
scale	0.1
range low	0
range high	65534
error value	65535
Module versions	CIF-Module Modbus RTU (1.00...99.99)

(signal-ID: 29)

This is the base signal. This signal represents the (calculated) flow. Calculated values are not suitable for closed loop control applications due to restricted availability and precision over the range of operation.

Support reference: Stratos MAXO; Stratos; IL_E, ...;

6.2.7.4.25 Flow (estimated) min-pres-value

property	value
address	25
scope	pump system
function	output value
data type	UINT
unit	m ³ /h
scale	0.1
range low	0
range high	65534
error value	65535
Module versions	CIF-Module Modbus RTU (1.00...99.99)

(signal-ID: 29)

This is the base signal. This signal represents the (calculated) flow. Calculated values are not suitable for closed loop control applications due to restricted availability and precision over the range of operation.

Support reference: Stratos MAXO; Stratos; IL_E, ...;

6.2.7.4.26 Supported Errors

property	value
address	26
scope	pump system
function	output value
data type	WORD
range low	0
range high	65535
Module versions	CIF-Module Modbus RTU (1.00...99.99)

(signal-ID:)

This is the base signal. This register returns the supported errors that can be read in Input Register 37. Notice: This register is available for compatibility reasons and will be removed in future software versions. Therefore it indicates the support of all errors (value 0xFFFF).

6.2.7.4.27 Supported Service Messages

property	value
address	27
scope	pump system
function	output value
data type	WORD
range low	0
range high	65535
Module versions	CIF-Module Modbus RTU (1.00...99.99)

(signal-ID:)

This is the base signal. This Input register returns the supported service messages that can be read in the Input register address 35 (Service Message). Notice: This register is available for compatibility reasons and will be removed in future software versions. Therefore it indicates the support of all service messages (value 0xFFFF).

6.2.7.4.28 power input max-pres-value

property	value
address	28
scope	pump system
function	output value
data type	UINT
unit	W
scale	1
range low	0
range high	65534
error value	65535
Module versions	CIF-Module Modbus RTU (1.00...99.99)

(signal-ID: 4)

This is the base signal. This signal represents the current electrical input power.

Support reference: Stratos MAXO; Stratos; IL_E, ...; MVIE, ...;

6.2.7.4.35 Service Message

property	value
address	35
scope	pump system
function	output value
data type	WORD
Module versions	CIF-Module Modbus RTU (1.00...99.99)

(signal-ID:)

bit	Name	description	support	version
0	Service Required	This is the base signal. This signal shows a required service action for the device. It does not mean any current insufficiency for the operation.	GLANDLESS, GLANDED_SINGLE, GLANDED_MULTI, PLC_MAP	CIF-Module Modbus RTU (1.00... 99.99), IF-Module Modbus Stratos (1.13... 99.99), IF-Module Modbus (1.13... 99.99)
1	FALSE	This is the base signal. This signal represens a static '0' bit, typically for compatibility purpose. For write acces, this bit shall always be '0'.	PLC_INT	CIF-Module Modbus RTU (1.00... 99.99), IF-Module Modbus Stratos (1.13... 99.99), IF-Module Modbus (1.13... 99.99)
2	FALSE	This is the base signal. This signal represens a static '0' bit, typically for compatibility purpose. For write acces, this bit shall always be '0'.	PLC_INT	CIF-Module Modbus RTU (1.00... 99.99), IF-Module Modbus Stratos (1.13... 99.99), IF-Module Modbus (1.13... 99.99)
3	FALSE	This is the base signal. This signal represens a static '0' bit, typically for compatibility purpose. For write acces, this bit shall always be '0'.	PLC_INT	CIF-Module Modbus RTU (1.00... 99.99), IF-Module Modbus Stratos (1.13... 99.99), IF-Module Modbus (1.13... 99.99)

This is the base signal. This Input register returns the current service actions needed.

6.2.7.4.36 Error Type

property	value
address	36
scope	pump system
function	output value
data type	WORD
Module versions	CIF-Module Modbus RTU (1.00...99.99)
(signal-ID:)	

bit	Name	description	support	version
0	Status Module error	This is the base signal. This signal shows an error inside the electronic module.	PLC_MAP	CIF-Module Modbus RTU (1.00... 99.99), IF-Module Modbus Stratos (1.13... 99.99), IF-Module Modbus (1.13... 99.99)
1	Status Motor error	This is the base signal. This signal is set, if the motor has a failure.	PLC_MAP	CIF-Module Modbus RTU (1.00... 99.99), IF-Module Modbus Stratos (1.13... 99.99), IF-Module Modbus (1.13... 99.99)
3	Error Present	This is the base signal. This signal shows an error of the pump. It means that the motor is currently stopped. A start retry will be performed.	GLANDLESS, GLANDED_SINGLE, GLANDED_MULTI, PLC_MAP	CIF-Module Modbus RTU (1.00... 99.99), IF-Module Modbus Stratos (1.13... 99.99), IF-Module Modbus (1.13... 99.99)
4	Status supply voltage error	This is the base signal. This signal is set if the supply voltage is not adequate for operation.	PLC_MAP	CIF-Module Modbus RTU (1.00... 99.99), IF-Module Modbus Stratos (1.13... 99.99), IF-Module Modbus (1.13... 99.99)

This is the base signal. This Input register returns the pump error. If one bit is active an error is present. A possible list of errors is located in the pump manual.

6.2.7.4.37 Error Message

property	value
address	37
scope	pump system
function	output value
data type	WORD
Module versions	CIF-Module Modbus RTU (1.00...99.99)

(signal-ID:)

bit	Name	description	support	version
0	Status Undervoltage	This is the base signal. This signal shows that the supply voltage for the device is insufficient.	PLC_MAP	CIF-Module Modbus RTU (1.00...99.99), IF-Module Modbus Stratos (1.13...99.99), IF-Module Modbus (1.13...99.99)
1	Status Overvoltage	This is the base signal. This signal shows that the supply voltage for the device is too high.	PLC_MAP	CIF-Module Modbus RTU (1.00...99.99), IF-Module Modbus Stratos (1.13...99.99), IF-Module Modbus (1.13...99.99)
2	Status Phase fault	This is the base signal. This signal shows that the supply has a phase fault. At least the supply via one phase is insufficient.	PLC_MAP	CIF-Module Modbus RTU (1.00...99.99), IF-Module Modbus Stratos (1.13...99.99), IF-Module Modbus (1.13...99.99)
3	Status Idle running	This is the base signal. This signal shows an idling state of the pump. The minimum load for the current speed is not reached (due to e.g. air in in the system).	PLC_MAP	CIF-Module Modbus RTU (1.00...99.99), IF-Module Modbus Stratos (1.13...99.99), IF-Module Modbus (1.13...99.99)
8	Status Motor overheated	This is the base signal. This signal is set, if the motor temperature is too high.	PLC_MAP	CIF-Module Modbus RTU (1.00...99.99), IF-Module Modbus Stratos (1.13...99.99), IF-Module Modbus (1.13...99.99)
9	Status Motor error	This is the base signal. This signal is set, if the motor has a failure.	PLC_MAP	CIF-Module Modbus RTU (1.00...99.99), IF-Module Modbus Stratos (1.13...99.99), IF-Module Modbus (1.13...99.99)
10	Status Pump blocked	This is the base signal. This signal is set, if the shaft of the motor is blocked. This may occur due to a blocked impeller or corrosion.	PLC_MAP	CIF-Module Modbus RTU (1.00...99.99), IF-Module Modbus Stratos (1.13...99.99), IF-Module Modbus (1.13...99.99)
11	Status Module overheated	This is the base signal. This signal is set, if the temperature of the electronic module is too high.	PLC_MAP	CIF-Module Modbus RTU (1.00...99.99), IF-Module Modbus Stratos (1.13...99.99), IF-Module Modbus (1.13...99.99)
12	Status Module warning	This is the base signal. This signal is set as a warning from the electronic module that performance may become insufficient.	PLC_MAP	CIF-Module Modbus RTU (1.00...99.99), IF-Module Modbus Stratos (1.13...99.99), IF-Module Modbus (1.13...99.99)
13	Status Module error	This is the base signal. This signal shows an error inside the electronic module.	PLC_MAP	CIF-Module Modbus RTU (1.00...99.99), IF-Module Modbus Stratos (1.13...99.99), IF-Module Modbus (1.13...99.99)
14	Status sensor malfunction	This is the base signal. This signal shows an error of an internal or external sensor.	PLC_MAP	CIF-Module Modbus RTU (1.00...99.99), IF-Module Modbus Stratos (1.13...99.99), IF-Module Modbus (1.13...99.99)

This is the base signal. This Input register returns the error as a bitset . No warnings are transmitted over the bus, only Errors (when the SSM relay becomes active in the Pump). Notice: This register is available for compatibility reasons and will be removed in future software versions, for new projects please use register 940/950. They represent the Wilo error code.

6.2.7.4.38 Pump Status

property	value
address	38
scope	pump system
function	output value
data type	WORD
Module versions	CIF-Module Modbus RTU (1.00...99.99)

(signal-ID:)

bit	Name	description	support	version
0	Pump on	This is the base signal. This signal represents the normal "ON" command. This signal is effective, if no override functions are active.	GLANDLESS,GLANDED_SINGLE,GLANDED_MULTI,STRATOS_MAXO	CIF-Module Modbus RTU (1.00...99.99), IF-Module Modbus Stratos (1.13...99.99), IF-Module Modbus (1.13...99.99)
1	FALSE	This is the base signal. This signal represents a static '0' bit, typically for compatibility purpose. For write acces, this bit shall always be '0'.	PLC_INT	CIF-Module Modbus RTU (1.00...99.99), IF-Module Modbus Stratos (1.13...99.99), IF-Module Modbus (1.13...99.99)
2	Status setpoint difference	This is the base signal. This signal shows that the setpoint is not reached. Possible causes are an insufficient pump size or a setpoint which is lower than the minimal setpoint.	GLANDLESS,GLANDED_SINGLE,GLANDED_MULTI	CIF-Module Modbus RTU (1.00...99.99), IF-Module Modbus Stratos (1.13...99.99), IF-Module Modbus (1.13...99.99)
3	Override off	This is the base signal. This signal overrides the pump (system) command with "OFF" command.	GLANDLESS,GLANDED_SINGLE,GLANDED_MULTI,STRATOS_MAXO	CIF-Module Modbus RTU (1.00...99.99), IF-Module Modbus Stratos (1.13...99.99), IF-Module Modbus (1.13...99.99)

bit	Name	description	support	version
4	Pump configuration double pump	This is the base signal. This signal shows that the pump system is a double pump.	GLANDLESS, GLANDED_SINGLE, STRATOS_MAXO	CIF-Module Modbus RTU (1.00...99.99), IF-Module Modbus Stratos (1.13...99.99), IF-Module Modbus (1.13...99.99)
5	Status local operation active	This is the base signal. This signal shows that the control via this communication channel is overridden by a local action at the device.	GLANDLESS, GLANDED_SINGLE, GLANDED_MULTI, STRATOS_MAXO	CIF-Module Modbus RTU (1.00...99.99), IF-Module Modbus Stratos (1.13...99.99), IF-Module Modbus (1.13...99.99)
6	Status Q/H values invalid	This is the base signal. This signal shows that the values for flow (Q) and/or (differential) pressure are invalid.	GLANDLESS, GLANDED_SINGLE, GLANDED_MULTI, PLC_MAP	CIF-Module Modbus RTU (1.00...99.99), IF-Module Modbus Stratos (1.13...99.99), IF-Module Modbus (1.13...99.99)
7	Override min	This is the base signal. This signal overrides the pump (system) command with "MIN" command.	GLANDLESS, GLANDED_SINGLE, GLANDED_MULTI, STRATOS_MAXO	CIF-Module Modbus RTU (1.00...99.99), IF-Module Modbus Stratos (1.13...99.99), IF-Module Modbus (1.13...99.99)

bit	Name	description	support	version
13	Wink Service	This is the base signal. If the menuitem "ID" in the device menu is activated, this signal is activated for a few seconds.	GLANDLESS, GLANDED_SINGLE, GLANDED_MULTI, STRATOS_MAXO	CIF-Module Modbus RTU (1.00...99.99), IF-Module Modbus Stratos (1.13...99.99), IF-Module Modbus (1.13...99.99)

This is the base signal. This Input register returns the current pump status. It contains detailed information about the controller.

6.2.7.4.39 State Diagnostics

property	value
address	39
scope	pump system
function	output value
data type	WORD
Module versions	CIF-Module Modbus RTU (1.00...99.99)

(signal-ID:)

bit	Name	description	support	version
0	Error Present	This is the base signal. This signal shows an error of the pump. It means that the motor is currently stopped. A start retry will be performed.	GLANDLESS, GLANDED_SINGLE, GLANDED_MULTI, PLC_MAP	CIF-Module Modbus RTU (1.00... 99.99), IF-Module Modbus Stratos (1.13... 99.99), IF-Module Modbus (1.13... 99.99)
1	Status supply voltage error	This is the base signal. This signal is set if the supply voltage is not adequate for operation.	PLC_MAP	CIF-Module Modbus RTU (1.00... 99.99), IF-Module Modbus Stratos (1.13... 99.99), IF-Module Modbus (1.13... 99.99)
3	Status lower regulation limit	This is the base signal. This signal shows that the control output for the pump speed is at it's low limit. The pump (system) cannot follow the control signal in this direction.	GLANDLESS, GLANDED_SINGLE, GLANDED_MULTI, STRATOS_MAXO	CIF-Module Modbus RTU (1.00... 99.99), IF-Module Modbus Stratos (1.13... 99.99), IF-Module Modbus (1.13... 99.99)
4	Status high regulation limit	This is the base signal. This signal shows that the control output for the pump speed is as it's high limit. The pump (system) cannot follow the control signal in this direction.	GLANDLESS, GLANDED_SINGLE, GLANDED_MULTI, STRATOS_MAXO	CIF-Module Modbus RTU (1.00... 99.99), IF-Module Modbus Stratos (1.13... 99.99), IF-Module Modbus (1.13... 99.99)

bit	Name	description	support	version
6	Status setpoint out of range	This is the base signal. This signal shows that the setpoint is out of the possible range. The pump (system) will not perform according the setpoint.	GLANDLESS, GLANDED_SINGLE, GLANDED_MULTI, PLC_MAP	CIF-Module Modbus RTU (1.00... 99.99), IF-Module Modbus Stratos (1.13... 99.99), IF-Module Modbus (1.13... 99.99)
8	Status local operation active	This is the base signal. This signal shows that the control via this communication channel is overridden by a local action at the device.	GLANDLESS, GLANDED_SINGLE, GLANDED_MULTI, STRATOS_MAXO	CIF-Module Modbus RTU (1.00... 99.99), IF-Module Modbus Stratos (1.13... 99.99), IF-Module Modbus (1.13... 99.99)
10	Pump on	This is the base signal. This signal represents the normal "ON" command. This signal is effektive, if no override functions are active.	GLANDLESS, GLANDED_SINGLE, GLANDED_MULTI, STRATOS_MAXO	CIF-Module Modbus RTU (1.00... 99.99), IF-Module Modbus Stratos (1.13... 99.99), IF-Module Modbus (1.13... 99.99)

This is the base signal. This Input register returns some status information about the pump.

6.2.7.4.65 Pressure

property	value
address	65
scope	slave pump
function	output value
data type	UINT
unit	cm H ₂ O
scale	10
range low	0
range high	65534
error value	65535
Module versions	CIF-Module Modbus RTU (1.00...99.99)

(signal-ID: 32)

This is the base signal. This signal represents the current pressure at the pump system. Depending on the sensor arrangement, this value is an absolute or a differential pressure. It can also be a signal of a remote sensor. Some pump type operate without a pressure sensor. In this case, the value is calculated.

Support reference: Stratos MAXO; Stratos; IL_E, ...; MVIE, ...;

6.2.7.4.66 Flow (estimated)

property	value
address	66
scope	slave pump
function	output value
data type	UINT
unit	m ³ /h
scale	0.1
range low	0
range high	65534
error value	65535
Module versions	CIF-Module Modbus RTU (1.00...99.99)

(signal-ID: 29)

This is the base signal. This signal represents the (calculated) flow. Calculated values are not suitable for closed loop control applications due to restricted availability and precision over the range of operation.

Support reference: Stratos MAXO; Stratos; IL_E, ...;

6.2.7.4.67 Energy Consumption

property	value
address	67
scope	slave pump
function	output value
data type	UINT
unit	kWh
scale	1
range low	0
range high	65534
error value	65535
Module versions	CIF-Module Modbus RTU (1.00...99.99)

(signal-ID: 26)

This is the base signal. This value represent the totally consumed electrical energy. This value is suitable for an energy performance evaluation.

Support reference: Stratos MAXO; Stratos; IL_E, ...; MVIE, ...;

6.2.7.4.68 power input

property	value
address	68
scope	slave pump
function	output value
data type	UINT
unit	W
scale	1
range low	0
range high	65534
error value	65535
Module versions	CIF-Module Modbus RTU (1.00...99.99)

(signal-ID: 4)

This is the base signal. This signal represents the current electrical input power.

Support reference: Stratos MAXO; Stratos; IL_E, ...; MVIE, ...;

6.2.7.4.69 Operation Time

property	value
address	69
scope	slave pump
function	output value
data type	UINT
unit	h
scale	10
range low	0
range high	65534
error value	65535
Module versions	CIF-Module Modbus RTU (1.00...99.99)

(signal-ID: 139)

This is the base signal. This value represents the total time where the device was running (motor turning).

Support reference: Stratos MAXO; Stratos; IL_E, ...; MVIE, ...;

6.2.7.4.70 Electrical Current

property	value
address	70
scope	slave pump
function	output value
data type	UINT
unit	A
scale	0.1
range low	0
range high	65534
error value	65535
Module versions	CIF-Module Modbus RTU (1.00...99.99)

(signal-ID: 3)

This is the base signal. This signal represents the electrical input current.

Support reference: Stratos; IL_E, ... MVIE, ...(0.55...7.5 kW);

6.2.7.4.71 Speed

property	value
address	71
scope	slave pump
function	output value
data type	UINT
unit	1/min
scale	1
range low	0
range high	65534
error value	65535
Module versions	CIF-Module Modbus RTU (1.00...99.99)

(signal-ID: 31)

This is the base signal. This signal shows the rotational speed of the pump.

Support reference: Stratos MAXO; Stratos; IL_E, ...; MVIE, ...;

6.2.7.4.80 Pump Module (Slave)

property	value
address	80
scope	slave pump
function	output value
data type	BYTE
Module versions	CIF-Module Modbus RTU (1.00...99.99)

(signal-ID:)

bit	Name	description	support	version
0	TRUE	This is the base signal. This signal represens a static '1' bit, typically for compatibility purpose. For write acces, this bit shall always be '1'.	PLC_INT	CIF-Module Modbus RTU (1.00...99.99), IF-Module Modbus Stratos (1.13...99.99), IF-Module Modbus (1.13...99.99)

This is the base signal. This Input register returns the module type of the Slave in a double pump.

6.2.7.4.81 Pump Type (Slave)

property	value
address	81
scope	slave pump
function	output value
data type	BYTE
Module versions	CIF-Module Modbus RTU (1.00...99.99)

(signal-ID: 65)

value	Name	description	support
254	EXTENDED	This value is valid, but not covered by this enumeration.	CIF-/IF-Module internal;
255	INVALID	This value is invaid (error value).	CIF-/IF-Module internal;

This is the base signal. This signal shows the pump type in PLR notation. This signal is presented for compatibility reason. If this pump has no PLR pump type, the value EXTENDED will be returned.

Support reference: CIF-/IF-Module mapped;

6.2.7.4.100 Error Type (Slave)

property	value
address	100
scope	slave pump
function	output value
data type	WORD
Module versions	CIF-Module Modbus RTU (1.00...99.99)

(signal-ID:)

bit	Name	description	support	version
0	Status Module error	This is the base signal. This signal shows an error inside the electronic module.	PLC_MAP	CIF-Module Modbus RTU (1.00...99.99), IF-Module Modbus Stratos (1.13...99.99), IF-Module Modbus (1.13...99.99)
1	Status Motor error	This is the base signal. This signal is set, if the motor has a failure.	PLC_MAP	CIF-Module Modbus RTU (1.00...99.99), IF-Module Modbus Stratos (1.13...99.99), IF-Module Modbus (1.13...99.99)
3	Status supply voltage error	This is the base signal. This signal is set if the supply voltage is not adequate for operation.	PLC_MAP	CIF-Module Modbus RTU (1.00...99.99), IF-Module Modbus Stratos (1.13...99.99), IF-Module Modbus (1.13...99.99)
4	Status supply voltage error	This is the base signal. This signal is set if the supply voltage is not adequate for operation.	PLC_MAP	CIF-Module Modbus RTU (1.00...99.99), IF-Module Modbus Stratos (1.13...99.99), IF-Module Modbus (1.13...99.99)

This is the base signal. This Input register returns the error type of the Slave in a double pump.

6.2.7.4.102 Pump Status (Slave)

property	value
address	102
scope	slave pump
function	output value
data type	WORD
Module versions	CIF-Module Modbus RTU (1.00...99.99)

(signal-ID:)

bit	Name	description	support	version
0	Pump on	This is the base signal. This signal represents the normal "ON" command. This signal is effective, if no override functions are active.	GLANDLESS,GLANDED_SINGLE,GLANDED_MULTI,STRATOS_MAXO	CIF- Module Modbus RTU (1.00... 99.99), IF- Module Modbus Stratos (1.13... 99.99), IF- Module Modbus (1.13... 99.99)
1	FALSE	This is the base signal. This signal represents a static '0' bit, typically for compatibility purpose. For write access, this bit shall always be '0'.	PLC_INT	CIF- Module Modbus RTU (1.00... 99.99), IF- Module Modbus Stratos (1.13... 99.99), IF- Module Modbus (1.13... 99.99)
2	Status setpoint difference	This is the base signal. This signal shows that the setpoint is not reached. Possible causes are an insufficient pump size or a setpoint which is lower than the minimal setpoint.	GLANDLESS,GLANDED_SINGLE,GLANDED_MULTI	CIF- Module Modbus RTU (1.00... 99.99), IF- Module Modbus Stratos (1.13... 99.99), IF- Module Modbus (1.13... 99.99)
3	Override off	This is the base signal. This signal overrides the pump (system) command with "OFF" command.	GLANDLESS,GLANDED_SINGLE,GLANDED_MULTI,STRATOS_MAXO	CIF- Module Modbus RTU (1.00... 99.99), IF- Module Modbus Stratos (1.13... 99.99), IF- Module Modbus (1.13... 99.99)

bit	Name	description	support	version
4	Pump configuration double pump	This is the base signal. This signal shows that the pump system is a double pump.	GLANDLESS, GLANDED_SINGLE, STRATOS_MAXO	CIF-Module Modbus RTU (1.00...99.99), IF-Module Modbus Stratos (1.13...99.99), IF-Module Modbus (1.13...99.99)
5	Status local operation active	This is the base signal. This signal shows that the control via this communication channel is overridden by a local action at the device.	GLANDLESS, GLANDED_SINGLE, GLANDED_MULTI, STRATOS_MAXO	CIF-Module Modbus RTU (1.00...99.99), IF-Module Modbus Stratos (1.13...99.99), IF-Module Modbus (1.13...99.99)
6	Status Q/H values invalid	This is the base signal. This signal shows that the values for flow (Q) and/or (differential) pressure are invalid.	GLANDLESS, GLANDED_SINGLE, GLANDED_MULTI, PLC_MAP	CIF-Module Modbus RTU (1.00...99.99), IF-Module Modbus Stratos (1.13...99.99), IF-Module Modbus (1.13...99.99)
7	Override min	This is the base signal. This signal overrides the pump (system) command with "MIN" command.	GLANDLESS, GLANDED_SINGLE, GLANDED_MULTI, STRATOS_MAXO	CIF-Module Modbus RTU (1.00...99.99), IF-Module Modbus Stratos (1.13...99.99), IF-Module Modbus (1.13...99.99)

bit	Name	description	support	version
13	Wink Service	This is the base signal. If the menuitem "ID" in the device menu is activated, this signal is activated for a few seconds.	GLANDLESS, GLANDED_SINGLE, GLANDED_MULTI, STRATOS_MAXO	CIF-Module Modbus RTU (1.00...99.99), IF-Module Modbus Stratos (1.13...99.99), IF-Module Modbus (1.13...99.99)

This is the base signal. This Input register returns the pump status of the Slave in a double pump.

6.2.7.4.200 duty point (rel.)

property	value
address	200
scope	pump system
function	active value
data type	INT
unit	%
scale	0.5
range low	-32768
range high	32766
error value	32767
Module versions	CIF-Module Modbus RTU (3.00...99.99)

(signal-ID: 1)

This is the base signal. It contains the relative duty point of the device. The valid range is not necessarily 0...100 %. a duty point of 0 % is not necessarily linked to the OFF state of the device.

Support reference: CIF-/IF-Module mapped; Stratos; IL_E, ...; MVIE, ...;

6.2.7.4.202 duty point (rel.) maximum-output

property	value
address	202
scope	pump system
function	active value
data type	INT
unit	%
scale	0.5
range low	-32768
range high	32766
error value	32767
Module versions	CIF-Module Modbus RTU (3.00...99.99)

(signal-ID: 1)

This is the base signal. It contains the relative duty point of the device. The valid range is not necessarily 0...100 %. a duty point of 0 % is not necessarily linked to the OFF state of the device.

Support reference: CIF-/IF-Module mapped; Stratos; IL_E, ...; MVIE, ...;

6.2.7.4.204 duty point (rel.) minimum-output

property	value
address	204
scope	pump system
function	active value
data type	INT
unit	%
scale	0.5
range low	-32768
range high	32766
error value	32767
Module versions	CIF-Module Modbus RTU (3.00...99.99)

(signal-ID: 1)

This is the base signal. It contains the relative duty point of the device. The valid range is not necessarily 0...100 %. a duty point of 0 % is not necessarily linked to the OFF state of the device.

Support reference: CIF-/IF-Module mapped; Stratos; IL_E, ...; MVIE, ...;

6.2.7.4.206 duty point 100 % value

property	value
address	206
scope	pump system
function	active value
data type	REAL
unit	-
scale	1
Module versions	CIF-Module Modbus RTU (3.00...99.99)

(signal-ID: 186)

This is the base signal. This signal represent the 100 % reference value for the duty point in the current control function.

Support reference: CIF-/IF-Module mapped;

6.2.7.4.208 duty point (rel.) units

property	value
address	208
scope	pump system
function	active value
data type	UINT
Module versions	CIF-Module Modbus RTU (3.00...99.99)

(signal-ID: 1)

This is the base signal. It contains the relative duty point of the device. The valid range is not necessarily 0...100 %. a duty point of 0 % is not necessarily linked to the OFF state of the device.

Support reference: CIF-/IF-Module mapped; Stratos; IL_E, ...; MVIE, ...;

6.2.7.4.210 Setpoint Signal Source

property	value
address	210
scope	pump system
function	active value
data type	BYTE
Module versions	CIF-Module Modbus RTU (3.00...99.99)

(signal-ID: 92)

value	Name	description	support
1	IF-Module	Signal source for setpoint: IF-Module	Stratos MAXO; Stratos; IL_E, ...; MVIE, ...;
2	0...10 V	Signal source for setpoint: IN2 mode 0...10 V	CIF-/IF-Module mapped; Stratos; IL_E, ...; MVIE, ...;
3	2...10 V	Signal source for setpoint: IN2 mode 2...10 V	CIF-/IF-Module mapped; IL_E, ...; MVIE, ...;
4	0...20 mA	Signal source for setpoint: IN2 mode 0...20 mA	CIF-/IF-Module mapped; IL_E, ...; MVIE, ...;
5	4...20 mA	Signal source for setpoint: IN2 mode 4...20 mA	CIF-/IF-Module mapped; IL_E, ...; MVIE, ...;
6	Internal	Signal source for setpoint: internal	Stratos MAXO;
7	EXT 1	Signal source for setpoint: EXT 1	Stratos MAXO;
8	EXT 2	Signal source for setpoint: EXT 2	Stratos MAXO;
9	INVALID	Invalid value	CIF-/IF-Module internal;

This is the base signal. This signal represents the source for the setpoint for the current control function.

Support reference: Stratos MAXO; Stratos; IL_E, ...; MVIE, ...;

6.2.7.4.300 power heating

property	value
address	300
scope	pump system
function	output value
data type	REAL
unit	W
scale	1
Module versions	CIF-Module Modbus RTU (3.00...99.99)

(signal-ID: 179)

This is the base signal. This signal shows the heating power in the measured hydronic circuit.

Support reference: Stratos MAXO;

6.2.7.4.302 power refrigeration

property	value
address	302
scope	pump system
function	output value
data type	REAL
unit	W
scale	1
Module versions	CIF-Module Modbus RTU (3.00...99.99)

(signal-ID: 180)

This is the base signal. This signal shows the refrigeration power in the measured hydronic circuit.

Support reference: Stratos MAXO;

6.2.7.4.304 Energy heating resettable

property	value
address	304
scope	pump system
function	output value
data type	REAL
unit	kWh
scale	1
Module versions	CIF-Module Modbus RTU (3.00...99.99)

(signal-ID: 176)

This is the base signal. This signal shows the accumulated heating energy in the measured hydronic circuit. This value can be resetted. N.B.: Reset is not necessarily possible on this interface

Support reference: Stratos MAXO;

6.2.7.4.308 Energy refrigeration resettable

property	value
address	308
scope	pump system
function	output value
data type	REAL
unit	kWh
scale	1
Module versions	CIF-Module Modbus RTU (3.00...99.99)

(signal-ID: 178)

This is the base signal. This signal shows the accumulated refrigeration energy in the measured hydronic circuit. This value can be resetted. N.B.: Reset is not necessarily possible on this interface

Support reference: Stratos MAXO;

6.2.7.4.312 Energy heating total

property	value
address	312
scope	pump system
function	output value
data type	REAL
unit	kWh
scale	1
Module versions	CIF-Module Modbus RTU (3.00...99.99)

(signal-ID: 9006)

This is the base signal. This signal shows the accumulated heating energy in the measured hydronic circuit. This value can be resetted. N.B.: Reset is not necessarily possible on this interface

Support reference: Stratos MAXO;

6.2.7.4.314 Energy refrigeration total

property	value
address	314
scope	pump system
function	output value
data type	REAL
unit	kWh
scale	1
Module versions	CIF-Module Modbus RTU (3.00...99.99)

(signal-ID: 9007)

This is the base signal. This signal shows the accumulated refrigeration energy in the measured hydronic circuit. This value can be resetted. N.B.: Reset is not necessarily possible on this interface

Support reference: Stratos MAXO;

6.2.7.4.316 temperature fluid forward

property	value
address	316
scope	pump system
function	output value
data type	UINT
unit	K
scale	0.1
Module versions	CIF-Module Modbus RTU (3.00...99.99)

(signal-ID: 181)

This is the base signal. This signal represents the forward fluid temperature of the hydronic circuit.

Support reference: Stratos MAXO;

6.2.7.4.318 temperature fluid return

property	value
address	318
scope	pump system
function	output value
data type	UINT
unit	K
scale	0.1
Module versions	CIF-Module Modbus RTU (3.00...99.99)

(signal-ID: 182)

This is the base signal. This signal represents the return fluid temperature of the hydronic circuit.

Support reference: Stratos MAXO;

6.2.7.4.320 Voltage Input

property	value
address	320
scope	pump system
function	output value
data type	UINT
unit	V
scale	0.1
Module versions	CIF-Module Modbus RTU (3.00...99.99)

(signal-ID: 91)

This is the base signal. This signal represents the input voltage.

Support reference: Stratos MAXO; Stratos; IL_E, ...; MVIE, ...;

6.2.7.4.324 Analog In 1 Measured Value

property	value
address	324
scope	pump system
function	output value
data type	REAL
unit	-
scale	1
Module versions	CIF-Module Modbus RTU (3.00...99.99)

(signal-ID: 9001)

This is the base signal. This signal represents the measured value of the analog input #1.

Support reference: Stratos MAXO;

6.2.7.4.326 Analog In 2 Measured Value

property	value
address	326
scope	pump system
function	output value
data type	REAL
unit	-
scale	1
Module versions	CIF-Module Modbus RTU (3.00...99.99)

(signal-ID: 9002)

This is the base signal. This signal represents the measured value of the analog input #2.

Support reference: Stratos MAXO;

6.2.7.4.400 duty point (rel.)

property	value
address	400
scope	pump system
function	output value
data type	INT
unit	%
scale	0.5
range low	-32768
range high	32766
error value	32767
Module versions	CIF-Module Modbus RTU (1.00...99.99)

(signal-ID: 1)

This is the base signal. It contains the relative duty point of the device. The valid range is not necessarily 0...100 %. a duty point of 0 % is not necessarily linked to the OFF state of the device.

Support reference: CIF-/IF-Module mapped; Stratos; IL_E, ...; MVIE, ...;

6.2.7.4.402 Effective Pump Command

property	value
address	402
scope	pump system
function	active value
data type	BYTE
Module versions	CIF-Module Modbus RTU (1.00...99.99)

(signal-ID:)

bit	Name	description	support	version
0	Pump on	This is the base signal. This signal represents the normal "ON" command. This signal is effective, if no override functions are active.	GLANDLESS, GLANDED_SINGLE, GLANDED_MULTI, STRATOS_MAXO	CIF-Module Modbus RTU (1.00... 99.99), IF-Module Modbus Stratos (1.13... 99.99), IF-Module Modbus (1.13... 99.99)
1	Override min	This is the base signal. This signal overrides the pump (system) command with "MIN" command.	GLANDLESS, GLANDED_SINGLE, GLANDED_MULTI, STRATOS_MAXO	CIF-Module Modbus RTU (1.00... 99.99), IF-Module Modbus Stratos (1.13... 99.99), IF-Module Modbus (1.13... 99.99)
2	Override max	This is the base signal. This signal overrides the pump (system) command with "MAX" command.	GLANDLESS, GLANDED_SINGLE, GLANDED_MULTI, STRATOS_MAXO	CIF-Module Modbus RTU (1.00... 99.99), IF-Module Modbus Stratos (1.13... 99.99), IF-Module Modbus (1.13... 99.99)
3	TRUE	This is the base signal. This signal represens a static '1' bit, typically for compatibility purpose. For write acces, this bit shall always be '1'.	PLC_INT	CIF-Module Modbus RTU (3.00... 99.99), IF-Module Modbus Stratos (3.00... 99.99), IF-Module Modbus (3.00... 99.99)

bit	Name	description	support	version
4	Override off	This is the base signal. This signal overrides the pump (system) command with "OFF" command.	GLANDLESS, GLANDED_SINGLE, GLANDED_MULTI, STRATOS_MAXO	CIF-Module Modbus RTU (3.00...99.99), IF-Module Modbus Stratos (3.00...99.99), IF-Module Modbus (3.00...99.99)
5	Override on	This is the base signal. This signal overrides the pump (system) command with "ON" command.	GLANDLESS, GLANDED_SINGLE, GLANDED_MULTI, PLC_INT	CIF-Module Modbus RTU (3.00...99.99), IF-Module Modbus Stratos (3.00...99.99), IF-Module Modbus (3.00...99.99)

This is the base signal. This bitset defines the currently effective command.

6.2.7.4.404 Operation Status

property	value
address	404
scope	pump system
function	output value
data type	WORD
Module versions	CIF-Module Modbus RTU (1.00...99.99)

(signal-ID:)

bit	Name	description	support	version
0	Ready for Operation	This is the base signal. This signal indicates that the motor of the pump is capable to run in case of a valid "on" command.	GLANDLESS, GLANDED_SINGLE, GLANDED_MULTI, STRATOS_MAXO	CIF-Module Modbus RTU (1.00...99.99), IF-Module Modbus Stratos (1.13...99.99), IF-Module Modbus (1.13...99.99)
1	Pump on	This is the base signal. This signal represents the normal "ON" command. This signal is effective, if no override functions are active.	GLANDLESS, GLANDED_SINGLE, GLANDED_MULTI, STRATOS_MAXO	CIF-Module Modbus RTU (1.00...99.99), IF-Module Modbus Stratos (1.13...99.99), IF-Module Modbus (1.13...99.99)
2	Service Required	This is the base signal. This signal shows a required service action for the device. It does not mean any current insufficiency for the operation.	GLANDLESS, GLANDED_SINGLE, GLANDED_MULTI, PLC_MAP	CIF-Module Modbus RTU (1.00...99.99), IF-Module Modbus Stratos (1.13...99.99), IF-Module Modbus (1.13...99.99)
3	Warning Present	This is the base signal. This signal shows a warning regarding a possible insufficiency or switch off. It does not mean an effective insufficiency for the operation.	GLANDLESS, GLANDED_SINGLE, GLANDED_MULTI, PLC_MAP	CIF-Module Modbus RTU (1.00...99.99), IF-Module Modbus Stratos (1.13...99.99), IF-Module Modbus (1.13...99.99)

bit	Name	description	support	version
4	Error Present	This is the base signal. This signal shows an error of the pump. It means that the motor is currently stopped. A start retry will be performed.	GLANDLESS, GLANDED_SINGLE, GLANDED_MULTI, PLC_MAP	CIF-Module Modbus RTU (1.00...99.99), IF-Module Modbus Stratos (1.13...99.99), IF-Module Modbus (1.13...99.99)
5	Final Error present	This is the base signal. This signal shows a final error of the pump. It means that the motor is currently stopped. A start retry will not be performed.	GLANDLESS, GLANDED_SINGLE, GLANDED_MULTI, PLC_MAP	CIF-Module Modbus RTU (1.00...99.99), IF-Module Modbus Stratos (1.13...99.99), IF-Module Modbus (1.13...99.99)

This is the base signal. This input register reports some operation status information from the pump.

6.2.7.4.500 Heartbeat Count

property	value
address	500
scope	pump system
function	output value
data type	UDINT
unit	-
scale	1
range low	0
range high	4.29497e+9
error value	4.29497e+9
Module versions	CIF-Module Modbus RTU (1.00...99.99)

(signal-ID: 80)

This is the base signal. This register counts up the Heartbeats sent by the pump to the IF-Module. The counter is reset by a restart of the pump communication controller and power on of the pump.

Support reference: CIF-/IF-Module internal;

6.2.7.4.502 System Time

property	value
address	502
scope	pump system
function	output value
data type	UDINT
unit	s
scale	1
Module versions	CIF-Module Modbus RTU (3.00...99.99)

(signal-ID: 177)

This is the base signal. The time information used for the system is available here. Starting point is 1970-01-01 0:00 UTC.

Support reference: Stratos MAXO;

6.2.7.4.700 Application Version

property	value
address	700
scope	pump system
function	output value
data type	WORD
Module versions	CIF-Module Modbus RTU (1.00...99.99)

(signal-ID: 1999)

This is the base signal. This register contains the version of the IF-Module firmware where the main version (to the left of the dot) is coded into the high byte.

Support reference: CIF-/IF-Module internal;

6.2.7.4.702 Vendor ID

property	value
address	702
scope	pump system
function	output value
data type	DWORD
Module versions	CIF-Module Modbus RTU (1.00...99.99)

(signal-ID: 148)

value	Name	description	support
569	WILO_SE	This constant value represents the vendor ID of the product.	CIF-/IF-Module internal;

This is the base signal. This signal represents a vendor ID of the product for this communication channel.

Support reference: CIF-/IF-Module internal;

6.2.7.4.740 pump type CAN

property	value
address	740
scope	master pump
function	output value
data type	WORD
Module versions	CIF-Module Modbus RTU (1.00...99.99)

(signal-ID: 129)

value	Name	description	support
65534	EXTENDED	This value is valid, but not covered by this enumeration.	CIF-/IF-Module internal;
65535	INVALID	This value is invalid (error value).	CIF-/IF-Module internal;

This is the base signal. This signal shows the pump type in CAN notation. This signal is presented for compatibility reason. If this pump has no CAN pump type, a value of 65534 will be returned.

Support reference: CIF-/IF-Module mapped; Stratos; IL_E, ...; MVIE, ...;

6.2.7.4.750 pump type CAN

property	value
address	750
scope	slave pump
function	output value
data type	WORD
Module versions	CIF-Module Modbus RTU (1.00...99.99)

(signal-ID: 129)

value	Name	description	support
65534	EXTENDED	This value is valid, but not covered by this enumeration.	CIF-/IF-Module internal;
65535	INVALID	This value is invalid (error value).	CIF-/IF-Module internal;

This is the base signal. This signal shows the pump type in CAN notation. This signal is presented for compatibility reason. If this pump has no CAN pump type, a value of 65534 will be returned.

Support reference: CIF-/IF-Module mapped; Stratos; IL_E, ...; MVIE, ...;

6.2.7.4.901 User Trouble Code

property	value
address	901
scope	pump system
function	output value
data type	WORD
Module versions	CIF-Module Modbus RTU (3.00...99.99)

(signal-ID: 144)

value	Name	description	support
0	CODE_0	no error	CIF-/IF-Module mapped; Stratos MAXO;
401	CODE_401	Voltage fluctuations in Mains	CIF-/IF-Module mapped; Stratos MAXO;
402	CODE_402	Mains voltage too low	CIF-/IF-Module mapped; Stratos MAXO;
403	CODE_403	Mains voltage too high	CIF-/IF-Module mapped; Stratos MAXO;
404	CODE_404	Shaft is mechanically blocked or motor defect	CIF-/IF-Module mapped; Stratos MAXO;
405	CODE_405	Electronic module temperature too high	CIF-/IF-Module mapped; Stratos MAXO;
406	CODE_406	Motor temperature too high or connection of motor PTC resistor	CIF-/IF-Module mapped; Stratos MAXO;
407	CODE_407	Contact between motor and module, motor or module defect	CIF-/IF-Module mapped; Stratos MAXO;
408	CODE_408	The flow is driving the pump impeller (flow against flow direction)	CIF-/IF-Module mapped; Stratos MAXO;
409	CODE_409	Software update incomplete	CIF-/IF-Module mapped; Stratos MAXO;
410	CODE_410	External input power supply overload and binary Ext Off	CIF-/IF-Module mapped; Stratos MAXO;
420	CODE_420	Motor or electronic Module defect	CIF-/IF-Module mapped; Stratos MAXO;
421	CODE_421	Electronic Module Defect	CIF-/IF-Module mapped; Stratos MAXO;
550	CODE_550	The flow is driving the pump impeller (flow against flow direction)	CIF-/IF-Module mapped; Stratos MAXO;
551	CODE_551	Mains voltage too low	CIF-/IF-Module mapped; Stratos MAXO;
552	CODE_552	Pump operated in generator mode (flow in flow direction)	CIF-/IF-Module mapped; Stratos MAXO;
553	CODE_553	Electronic module failure	CIF-/IF-Module mapped; Stratos MAXO;
555	CODE_555	Sensorvalue implausible on Analog In 1	CIF-/IF-Module mapped; Stratos MAXO;
556	CODE_556	Open Loop on Analog In 1	CIF-/IF-Module mapped; Stratos MAXO;
557	CODE_557	Sensor value implausible on Analog In 2	CIF-/IF-Module mapped; Stratos MAXO;
558	CODE_558	Open Loop on Analog In 2	CIF-/IF-Module mapped; Stratos MAXO;
559	CODE_559	electronic module temperature too high	CIF-/IF-Module mapped; Stratos MAXO;
560	CODE_560	Software Update incomplete	CIF-/IF-Module mapped; Stratos MAXO;
561	CODE_561	External Input Power Supply Overload and Binary Input not available	CIF-/IF-Module mapped; Stratos MAXO;
562	CODE_562	External Input Power Supply Overload and Analog Input not available	CIF-/IF-Module mapped; Stratos MAXO;
563	CODE_563	IF module sensor input missing	CIF-/IF-Module mapped; Stratos MAXO;
564	CODE_564	IF module setpoint input missing	CIF-/IF-Module mapped; Stratos MAXO;
565	CODE_565	Input signal too high on Analog In 1	CIF-/IF-Module mapped; Stratos MAXO;
566	CODE_566	Input signal too high on Analog In 2	CIF-/IF-Module mapped; Stratos MAXO;
567	CODE_567	Sensor calibration missing (Sensor + Module)	CIF-/IF-Module mapped; Stratos MAXO;
568	CODE_568	Sensor defect	CIF-/IF-Module mapped; Stratos MAXO;
569	CODE_569	Configuration lost	CIF-/IF-Module mapped; Stratos MAXO;

value	Name	description	support
570	CODE_570	Electronic module temperature too high	CIF-/IF-Module mapped; Stratos MAXO;
571	CODE_571	Double pump connection lost	CIF-/IF-Module mapped; Stratos MAXO;
572	CODE_572	Dry running	CIF-/IF-Module mapped; Stratos MAXO;
573	CODE_573	No communication to HMI	CIF-/IF-Module mapped; Stratos MAXO;
574	CODE_574	No communication to IF module	CIF-/IF-Module mapped; Stratos MAXO;
575	CODE_575	No Bluetooth communication	CIF-/IF-Module mapped; Stratos MAXO;
576	CODE_576	No communication to Wilo sensor	CIF-/IF-Module mapped; Stratos MAXO;
577	CODE_577	Software update aborted	CIF-/IF-Module mapped; Stratos MAXO;
578	CODE_578	HMI defect	CIF-/IF-Module mapped; Stratos MAXO;
579	CODE_579	HMI software incomplete	CIF-/IF-Module mapped; Stratos MAXO;
580	CODE_580	Number of wrong key inputs reached	CIF-/IF-Module mapped; Stratos MAXO;
581	CODE_581	Double pump type mismatch	CIF-/IF-Module mapped; Stratos MAXO;
582	CODE_582	Double pump incompatibility	CIF-/IF-Module mapped; Stratos MAXO;
583	CODE_583	Fluid over temperature	CIF-/IF-Module mapped; Stratos MAXO;
601	CODE_601	Configuration: Setpoint Ext1/2 for CF1 or CF2_H	CIF-/IF-Module mapped; Stratos MAXO;
602	CODE_602	Configuration: Setpoint IF Module for CF1 or CF2_H	CIF-/IF-Module mapped; Stratos MAXO;
603	CODE_603	Configuration: Sensor1 Ext1/2 for CF1 or CF2_H	CIF-/IF-Module mapped; Stratos MAXO;
604	CODE_604	Configuration: Sensor1/2 identical for CF1 or CF2_H	CIF-/IF-Module mapped; Stratos MAXO;
606	CODE_606	Configuration: Sensor1 IF Module for CF1 or CF2_H	CIF-/IF-Module mapped; Stratos MAXO;
607	CODE_607	Configuration: Sensor2 Ext1/2 for CF1 or CF2_H	CIF-/IF-Module mapped; Stratos MAXO;
609	CODE_609	Configuration: Sensor2 IF Module for CF1 or CF2_H	CIF-/IF-Module mapped; Stratos MAXO;
610	CODE_610	Configuration: Sensor1 Ext1/2 for Heatmetering	CIF-/IF-Module mapped; Stratos MAXO;
611	CODE_611	Configuration: Sensor1/2 identical for Heatmetering	CIF-/IF-Module mapped; Stratos MAXO;
614	CODE_614	Configuration: Sensor1 IF Module for Heatmetering	CIF-/IF-Module mapped; Stratos MAXO;
615	CODE_615	Configuration: Sensor2 Ext1/2 for Heatmetering	CIF-/IF-Module mapped; Stratos MAXO;
618	CODE_618	Configuration: Sensor2 IF Module for Heatmetering	CIF-/IF-Module mapped; Stratos MAXO;
619	CODE_619	Configuration: Sensor Ext1/2 for Automatic Switching	CIF-/IF-Module mapped; Stratos MAXO;
621	CODE_621	Configuration: Sensor IF Module for Automatic Switching	CIF-/IF-Module mapped; Stratos MAXO;
641	CODE_641	Configuration: Setpoint Ext1/2 for CF2_C	CIF-/IF-Module mapped; Stratos MAXO;
642	CODE_642	Configuration: Setpoint IF Module for CF2_C	CIF-/IF-Module mapped; Stratos MAXO;
643	CODE_643	Configuration: Sensor1 Ext1/2 for CF2_C	CIF-/IF-Module mapped; Stratos MAXO;
644	CODE_644	Configuration: Sensor1/2 identical for CF2_C	CIF-/IF-Module mapped; Stratos MAXO;

value	Name	description	support
646	CODE_646	Configuration: Sensor1 IF Module for CF2_C	CIF-/IF-Module mapped; Stratos MAXO;
647	CODE_647	Configuration: Sensor2 Ext1/2 for CF2_C	CIF-/IF-Module mapped; Stratos MAXO;
649	CODE_649	Configuration: Sensor2 IF Module for CF2_C	CIF-/IF-Module mapped; Stratos MAXO;
888	CODE_888	not defined	CIF-/IF-Module mapped; Stratos MAXO;
999	CODE_999	do not show to user	CIF-/IF-Module mapped; Stratos MAXO;

This is the base signal. The current warning or error can be read out here. It is the WILO error code where the different codes can be found in the pump manual.

Support reference: Stratos MAXO;

6.2.7.4.940 Warning/Error Message

property	value
address	940
scope	master pump
function	output value
data type	BYTE
range low	0
range high	255
Module versions	CIF-Module Modbus RTU (1.00...99.99)

(signal-ID: 126)

value	Name	description	support
0	NO_ERROR	No error	CIF-/IF-Module mapped; Stratos MAXO; Stratos; IL_E, ...; MVIE, ...;
1	FLUID_FLOW_HI	Flow rate out of range, $Q > 1,1 * Q_{nominal}$	CIF-/IF-Module mapped; MVIE, ...;
2	FLUID_TEMP_LO	Fluid temperature < T min	CIF-/IF-Module mapped;
3	FLUID_TEMP_HI	Fluid temperature > T max	CIF-/IF-Module mapped; Stratos;
4	MAINS_VOLT_LO	mains under-voltage	CIF-/IF-Module mapped; Stratos; IL_E, ...; MVIE, ...;
5	MAINS_VOLT_HI	mains overvoltage	CIF-/IF-Module mapped; Stratos; IL_E, ...; MVIE, ...;
6	MAINS_PHASE	Missing mains phase	CIF-/IF-Module mapped; IL_E, ...; MVIE, ...;
7	PUMP_GENERATOR	Generator operation	CIF-/IF-Module mapped; Stratos; IL_E, ...; MVIE, ...;
8	PUMP_CAVITATION	Cavitation	CIF-/IF-Module mapped;
9	PUMP_TURBINE	Turbine mode	CIF-/IF-Module mapped; Stratos;
10	PUMP_BLOCKED	Blocked rotor	CIF-/IF-Module mapped; Stratos; IL_E, ...; MVIE, ...;
11	PUMP_DRY_RUN	Dry running	CIF-/IF-Module mapped; Stratos; MVIE, ...;
12	PUMP_ROUGH_IMP	Rough running impeller	CIF-/IF-Module mapped;
13	PUMP_CLOGGED	Clogged or unfastened impeller	CIF-/IF-Module mapped;
14	PUMP_LEAK_INT	Internal motor leakage sensor tripped	CIF-/IF-Module mapped;
15	PUMP_VIBRATION	Vibration over limit	CIF-/IF-Module mapped;
16	PUMP_ROT_DIR	Wrong rotation direction	CIF-/IF-Module mapped;
17	PUMP_LEAK_EXT	Water leakage	CIF-/IF-Module mapped;
18	PUMP_SEAL	Mechanical seal defect	CIF-/IF-Module mapped;
19	FLUID_FLOW_LOW	error volume flow pump	CIF-/IF-Module mapped;
20	MOT_TEMP_HI	Over temperature motor winding	CIF-/IF-Module mapped; Stratos; IL_E, ...; MVIE, ...;
21	MOT_TORQUE_HI	Overload motor (torque)	CIF-/IF-Module mapped; Stratos; IL_E, ...;
22	MOT_INSULATION	Motor insulation fault	CIF-/IF-Module mapped;
23	MOT_SHORT_CIRC	Short circuit (phase - phase, phase - ground)	CIF-/IF-Module mapped; Stratos; IL_E, ...; MVIE, ...;
24	MOT_CURR_LO	Current too low	CIF-/IF-Module mapped;
25	MOT_OPEN_CIRC	Missing motor/winding contact	CIF-/IF-Module mapped; Stratos; IL_E, ...; MVIE, ...;
26	MOT_TEMP_SENS	WSK or PTC cable break	CIF-/IF-Module mapped; IL_E, ...; MVIE, ...;
27	MOT_SPEED_SENS	Speed sensor defect	CIF-/IF-Module mapped;
28	MOT_BEARING	Bearing wear over limit	CIF-/IF-Module mapped;
29	MOT_TEMP_WARN	Pre alarm WSK	CIF-/IF-Module mapped;
30	MOD_TEMP_HI	Over temperature module	CIF-/IF-Module mapped; Stratos; IL_E, ...; MVIE, ...;
31	MOD_TEMP_COMP_HI	Over temperature power bridge / components	CIF-/IF-Module mapped; Stratos; IL_E, ...; MVIE, ...;
32	MOD_VOLT_DC_LO	Undervoltage DC link	CIF-/IF-Module mapped; IL_E, ...; MVIE, ...;
33	MOD_VOLT_DC_HI	Overvoltage DC link	CIF-/IF-Module mapped; IL_E, ...; MVIE, ...;
34	E034	Wrong combination pump - module	CIF-/IF-Module mapped;
35	E035	DP/MP: several same identity	CIF-/IF-Module mapped; IL_E, ...;
36	MOD_RELAY	Inrush current relay (Lader.) PFC defect (PFC) AD Converter (ADC) Synchronisation (Sync) Communication (Komm)	CIF-/IF-Module mapped; Stratos;
37	MOD_DC_LINK	DC link capacitor defect	CIF-/IF-Module mapped;
38	MOD_SENS_FLUID	PTC fluid defect	CIF-/IF-Module mapped; Stratos;

value	Name	description	support
39	E039	-	CIF-/IF-Module mapped;
40	SENS_PRESS	Ext. pressure sensor / switch defect	CIF-/IF-Module mapped;
41	SENS_ACC	Ext. acceleration sensor defect	CIF-/IF-Module mapped;
42	SENS_IN1	Connection to signal source at IN1 open loop / short circuit (2...10V/4...20mA)	CIF-/IF-Module mapped; MVIE, ...;
43	SENS_IN2	Connection to signal source at IN2 open loop / short circuit (2...10V/4...20mA)	CIF-/IF-Module mapped;
44	SENS_SPEED	Ext. Revolution speed sensor defect	CIF-/IF-Module mapped;
45	SENS_TEMP_1	Temperature sensor 1 defect	CIF-/IF-Module mapped;
46	SENS_TEMP_2	Temperature sensor 2 defect	CIF-/IF-Module mapped;
47	SENS_TEMP_3	Temperature sensor 3 defect	CIF-/IF-Module mapped;
48	E048	-	CIF-/IF-Module mapped;
49	E049	Expansion vessel / check valve	CIF-/IF-Module mapped;
50	COM_BMS	BMS-communication timeout	CIF-/IF-Module mapped; Stratos; IL_E, ...; MVIE, ...;
51	COM_DP	Not permitted combination DP/MP	CIF-/IF-Module mapped; Stratos; IL_E, ...;
52	COM_DP_TIMEOUT	DP/MP-communication timeout	CIF-/IF-Module mapped; Stratos; IL_E, ...;
53	COM_CAN_ADR	Double / multiple adress (for CAN bus communication)	CIF-/IF-Module mapped; Stratos;
54	COM_CAN_BIND	Binding not possible, bus device missing	CIF-/IF-Module mapped; Stratos; MVIE, ...;
55	COM_VFD	Frequency converter - communication error	CIF-/IF-Module mapped;
56	E056	-	CIF-/IF-Module mapped;
57	E057	-	CIF-/IF-Module mapped;
58	E058	-	CIF-/IF-Module mapped;
59	E059	-	CIF-/IF-Module mapped;
60	SYS_PRESS_HI	System over pressure	CIF-/IF-Module mapped;
61	SYS_PRESS_LO	System low pressure	CIF-/IF-Module mapped;
62	SYS_FLUID_LO	Lack of water (.x suffix for location)	CIF-/IF-Module mapped;
63	SYS_FLUID_LEAK	leakage in system (loss of water)	CIF-/IF-Module mapped;
64	SYS_FLUID_FROST	Frost protection	CIF-/IF-Module mapped;
65	SYS_FLUID_DRAIN	drainage failure	CIF-/IF-Module mapped;
66	SYS_FLUID_FLOOD	Flood (max. water level)	CIF-/IF-Module mapped;
67	SYS_OVD_FLUID_D	override of the standard discharge path (.x suffix for location)	CIF-/IF-Module mapped;
68	SYS_OVD_OFF	Priority off	CIF-/IF-Module mapped;
69	E069	-	CIF-/IF-Module mapped;
70	E070	Internal communication error	CIF-/IF-Module mapped; IL_E, ...; MVIE, ...;
71	E071	memory-error	CIF-/IF-Module mapped; IL_E, ...; MVIE, ...;
72	E072	Power components/ frequency converter	CIF-/IF-Module mapped; IL_E, ...; MVIE, ...;
73	E073	Frequency converter number	CIF-/IF-Module mapped;
74	E074	Internal fan defect	CIF-/IF-Module mapped;
75	E075	Inrush current relay defect	CIF-/IF-Module mapped; MVIE, ...;
76	E076	Current sensor defect	CIF-/IF-Module mapped; IL_E, ...;
77	E077	24V supply voltage defect	CIF-/IF-Module mapped; IL_E, ...;
78	E078	Unknown motor number	CIF-/IF-Module mapped;
79	E079	-	CIF-/IF-Module mapped;
80	PUMP_FAULT	Pump (collective fault)	CIF-/IF-Module mapped;
81	E081	Prealarm frequency converter (overtemperature, overload,...)	CIF-/IF-Module mapped;
82	E082	Frequency converter	CIF-/IF-Module mapped;
83	E083	-	CIF-/IF-Module mapped;
84	E084	-	CIF-/IF-Module mapped;
85	E085	-	CIF-/IF-Module mapped;

value	Name	description	support
86	E086	-	CIF-/IF-Module mapped;
87	E087	-	CIF-/IF-Module mapped;
88	E088	-	CIF-/IF-Module mapped;
89	MOT_MOD_FAULT	Motor or module fault	CIF-/IF-Module mapped;
90	E090	Implausible combination	CIF-/IF-Module mapped;
91	E091	-	CIF-/IF-Module mapped;
92	E092	-	CIF-/IF-Module mapped;
93	E093	-	CIF-/IF-Module mapped;
94	E094	-	CIF-/IF-Module mapped;
95	E095	-	CIF-/IF-Module mapped;
96	E096	Infobyte not set	CIF-/IF-Module mapped; IL_E, ...;
97	E097	Flexpump type data missing	CIF-/IF-Module mapped; IL_E, ...;
98	E098	Flexpump type data not valid (Checksum)	CIF-/IF-Module mapped; IL_E, ...;
99	E099	Pump type	CIF-/IF-Module mapped;
100	CTRL_BATT	Battery down	CIF-/IF-Module mapped;
101	PAN_TEMP_HI	Panel overtemperature	CIF-/IF-Module mapped;
102	PAN_TEMP_LO	Panel low temperature	CIF-/IF-Module mapped;
103	PAN_FAN_INT	Panel fan defect	CIF-/IF-Module mapped;
104	MOT_FAN_EXT	External fan motor defect	CIF-/IF-Module mapped;
105	CTRL_SHORT_CIRC	Control / power circuit short circuit (.x suffix for location)	CIF-/IF-Module mapped;
106	CTRL_OPEN_LOOP	Control / power circuit open loop (.x suffix for location)	CIF-/IF-Module mapped;
107	CTRL_ELEC_FAULT	Control / power circuit electrical fault (.x suffix for location)	CIF-/IF-Module mapped;
108	E108	Reserved block for controller faults	CIF-/IF-Module mapped;
109	CTRL_EXT_FAULT	external error	CIF-/IF-Module mapped;
110	E110	loss of sync	CIF-/IF-Module mapped;
111	E111	overcurrent	CIF-/IF-Module mapped;
112	E112	Motor speed higher than synchronous value	CIF-/IF-Module mapped;
113	E113		CIF-/IF-Module mapped;
114	E114		CIF-/IF-Module mapped;
115	E115		CIF-/IF-Module mapped;
116	E116		CIF-/IF-Module mapped;
117	E117		CIF-/IF-Module mapped;
118	E118		CIF-/IF-Module mapped;
119	MOT_TURBINE	turbine driven	CIF-/IF-Module mapped;
120	E120	Reserved	CIF-/IF-Module mapped;
121	E121	Sensor error motor PTC short circuit	CIF-/IF-Module mapped;
122	E122	Sensor error hybrid module open loop	CIF-/IF-Module mapped;
123	E123	Sensor error hybrid module short circuit	CIF-/IF-Module mapped;
124	E124	sensor error electronics open loop	CIF-/IF-Module mapped;
125	E125	sensor error electronics short circuit	CIF-/IF-Module mapped;
126	E126		CIF-/IF-Module mapped;
127	E127		CIF-/IF-Module mapped;
128	E128		CIF-/IF-Module mapped;
129	E129		CIF-/IF-Module mapped;
130	ENG_FUEL	fuel level low	CIF-/IF-Module mapped;
131	ENG_PREHEAT	preheating engine	CIF-/IF-Module mapped;
132	ENG_PRESS_OIL_LO	oil pressure	CIF-/IF-Module mapped;
133	ENG_TEMP_HI	overtemperature motor	CIF-/IF-Module mapped;
134	E134		CIF-/IF-Module mapped;
135	E135		CIF-/IF-Module mapped;
136	E136		CIF-/IF-Module mapped;
137	ENG_DRIVE_BELT	drive belt	CIF-/IF-Module mapped;
138	ENG_FLUID_LO	Cooling liquid level motor	CIF-/IF-Module mapped;
139	E139		CIF-/IF-Module mapped;

value	Name	description	support
140	E140	Monitoring switching frequency	CIF-/IF-Module mapped;
141	E141	Monitoring of runtime	CIF-/IF-Module mapped;
142	E142		CIF-/IF-Module mapped;
143	E143		CIF-/IF-Module mapped;
144	E144		CIF-/IF-Module mapped;
145	E145		CIF-/IF-Module mapped;
146	E146		CIF-/IF-Module mapped;
147	E147		CIF-/IF-Module mapped;
148	E148		CIF-/IF-Module mapped;
149	E149		CIF-/IF-Module mapped;
150	E150		CIF-/IF-Module mapped;
151	E151		CIF-/IF-Module mapped;
152	E152		CIF-/IF-Module mapped;
153	E153		CIF-/IF-Module mapped;
154	E154		CIF-/IF-Module mapped;
155	E155		CIF-/IF-Module mapped;
156	E156		CIF-/IF-Module mapped;
157	E157		CIF-/IF-Module mapped;
158	E158		CIF-/IF-Module mapped;
159	E159		CIF-/IF-Module mapped;
160	E160		CIF-/IF-Module mapped;
161	E161		CIF-/IF-Module mapped;
162	E162		CIF-/IF-Module mapped;
163	E163		CIF-/IF-Module mapped;
164	E164		CIF-/IF-Module mapped;
165	E165		CIF-/IF-Module mapped;
166	E166		CIF-/IF-Module mapped;
167	E167		CIF-/IF-Module mapped;
168	E168		CIF-/IF-Module mapped;
169	E169		CIF-/IF-Module mapped;
170	E170		CIF-/IF-Module mapped;
171	E171		CIF-/IF-Module mapped;
172	E172		CIF-/IF-Module mapped;
173	E173		CIF-/IF-Module mapped;
174	E174		CIF-/IF-Module mapped;
175	E175		CIF-/IF-Module mapped;
176	E176		CIF-/IF-Module mapped;
177	E177		CIF-/IF-Module mapped;
178	E178		CIF-/IF-Module mapped;
179	E179		CIF-/IF-Module mapped;
180	E180		CIF-/IF-Module mapped;
181	E181		CIF-/IF-Module mapped;
182	E182		CIF-/IF-Module mapped;
183	E183		CIF-/IF-Module mapped;
184	E184		CIF-/IF-Module mapped;
185	E185		CIF-/IF-Module mapped;
186	E186		CIF-/IF-Module mapped;
187	E187		CIF-/IF-Module mapped;
188	E188		CIF-/IF-Module mapped;
189	E189		CIF-/IF-Module mapped;
190	E190		CIF-/IF-Module mapped;
191	E191		CIF-/IF-Module mapped;
192	E192		CIF-/IF-Module mapped;
193	E193		CIF-/IF-Module mapped;
194	E194		CIF-/IF-Module mapped;
195	E195		CIF-/IF-Module mapped;
196	E196		CIF-/IF-Module mapped;
197	E197		CIF-/IF-Module mapped;
198	E198		CIF-/IF-Module mapped;
199	E199		CIF-/IF-Module mapped;

value	Name	description	support
200	SIM_A	Error type A (simulated)	CIF-/IF-Module mapped;
201	SIM_B	Error type B (simulated)	CIF-/IF-Module mapped;
202	SIM_C	Error type C (simulated)	CIF-/IF-Module mapped;
203	SIM_D	Error type D (simulated)	CIF-/IF-Module mapped;
204	SIM_E	Error type E (simulated)	CIF-/IF-Module mapped;
205	SIM_F	Warning type F (simulated)	CIF-/IF-Module mapped;
206	E206		CIF-/IF-Module mapped;
207	E207		CIF-/IF-Module mapped;
208	E208		CIF-/IF-Module mapped;
209	E209		CIF-/IF-Module mapped;
210	E210		CIF-/IF-Module mapped;
211	E211		CIF-/IF-Module mapped;
212	E212		CIF-/IF-Module mapped;
213	E213		CIF-/IF-Module mapped;
214	E214		CIF-/IF-Module mapped;
215	E215		CIF-/IF-Module mapped;
216	E216		CIF-/IF-Module mapped;
217	E217		CIF-/IF-Module mapped;
218	E218		CIF-/IF-Module mapped;
219	E219		CIF-/IF-Module mapped;
220	E220		CIF-/IF-Module mapped;
221	E221		CIF-/IF-Module mapped;
222	E222		CIF-/IF-Module mapped;
223	E223		CIF-/IF-Module mapped;
224	E224		CIF-/IF-Module mapped;
225	E225		CIF-/IF-Module mapped;
226	E226		CIF-/IF-Module mapped;
227	E227		CIF-/IF-Module mapped;
228	E228		CIF-/IF-Module mapped;
229	E229		CIF-/IF-Module mapped;
230	E230		CIF-/IF-Module mapped;
231	E231		CIF-/IF-Module mapped;
232	E232		CIF-/IF-Module mapped;
233	E233		CIF-/IF-Module mapped;
234	E234		CIF-/IF-Module mapped;
235	E235		CIF-/IF-Module mapped;
236	E236		CIF-/IF-Module mapped;
237	E237		CIF-/IF-Module mapped;
238	E238		CIF-/IF-Module mapped;
239	E239		CIF-/IF-Module mapped;
240	E240		CIF-/IF-Module mapped;
241	E241		CIF-/IF-Module mapped;
242	E242		CIF-/IF-Module mapped;
243	E243		CIF-/IF-Module mapped;
244	E244		CIF-/IF-Module mapped;
245	E245		CIF-/IF-Module mapped;
246	E246		CIF-/IF-Module mapped;
247	E247		CIF-/IF-Module mapped;
248	E248		CIF-/IF-Module mapped;
249	E249		CIF-/IF-Module mapped;
250	E250		CIF-/IF-Module mapped;
251	E251		CIF-/IF-Module mapped;
252	E252		CIF-/IF-Module mapped;
253	EXTENDED	extended code	CIF-/IF-Module mapped;
254	UNDEFINED	undefined error	CIF-/IF-Module mapped;
255	INVALID	invalid error	CIF-/IF-Module mapped;

This is the base signal. The current warning or error can be read out here. It is the WILO error code where the different codes can be found in the pump manual.

Support reference: Stratos; IL_E, ...; MVIE, ...;

6.2.7.4.950 Warning/Error Message

property	value
address	950
scope	slave pump
function	output value
data type	BYTE
range low	0
range high	255
Module versions	CIF-Module Modbus RTU (1.00...99.99)

(signal-ID: 126)

value	Name	description	support
0	NO_ERROR	No error	CIF-/IF-Module mapped; Stratos MAXO; Stratos; IL_E, ...; MVIE, ...;
1	FLUID_FLOW_HI	Flow rate out of range, $Q > 1,1 * Q_{nominal}$	CIF-/IF-Module mapped; MVIE, ...;
2	FLUID_TEMP_LO	Fluid temperature < T min	CIF-/IF-Module mapped;
3	FLUID_TEMP_HI	Fluid temperature > T max	CIF-/IF-Module mapped; Stratos;
4	MAINS_VOLT_LO	mains under-voltage	CIF-/IF-Module mapped; Stratos; IL_E, ...; MVIE, ...;
5	MAINS_VOLT_HI	mains overvoltage	CIF-/IF-Module mapped; Stratos; IL_E, ...; MVIE, ...;
6	MAINS_PHASE	Missing mains phase	CIF-/IF-Module mapped; IL_E, ...; MVIE, ...;
7	PUMP_GENERATOR	Generator operation	CIF-/IF-Module mapped; Stratos; IL_E, ...; MVIE, ...;
8	PUMP_CAVITATION	Cavitation	CIF-/IF-Module mapped;
9	PUMP_TURBINE	Turbine mode	CIF-/IF-Module mapped; Stratos;
10	PUMP_BLOCKED	Blocked rotor	CIF-/IF-Module mapped; Stratos; IL_E, ...; MVIE, ...;
11	PUMP_DRY_RUN	Dry running	CIF-/IF-Module mapped; Stratos; MVIE, ...;
12	PUMP_ROUGH_IMP	Rough running impeller	CIF-/IF-Module mapped;
13	PUMP_CLOGGED	Clogged or unfastened impeller	CIF-/IF-Module mapped;
14	PUMP_LEAK_INT	Internal motor leakage sensor tripped	CIF-/IF-Module mapped;
15	PUMP_VIBRATION	Vibration over limit	CIF-/IF-Module mapped;
16	PUMP_ROT_DIR	Wrong rotation direction	CIF-/IF-Module mapped;
17	PUMP_LEAK_EXT	Water leakage	CIF-/IF-Module mapped;
18	PUMP_SEAL	Mechanical seal defect	CIF-/IF-Module mapped;
19	FLUID_FLOW_LOW	error volume flow pump	CIF-/IF-Module mapped;
20	MOT_TEMP_HI	Over temperature motor winding	CIF-/IF-Module mapped; Stratos; IL_E, ...; MVIE, ...;
21	MOT_TORQUE_HI	Overload motor (torque)	CIF-/IF-Module mapped; Stratos; IL_E, ...;
22	MOT_INSULATION	Motor insulation fault	CIF-/IF-Module mapped;
23	MOT_SHORT_CIRC	Short circuit (phase - phase, phase - ground)	CIF-/IF-Module mapped; Stratos; IL_E, ...; MVIE, ...;
24	MOT_CURR_LO	Current too low	CIF-/IF-Module mapped;
25	MOT_OPEN_CIRC	Missing motor/winding contact	CIF-/IF-Module mapped; Stratos; IL_E, ...; MVIE, ...;
26	MOT_TEMP_SENS	WSK or PTC cable break	CIF-/IF-Module mapped; IL_E, ...; MVIE, ...;
27	MOT_SPEED_SENS	Speed sensor defect	CIF-/IF-Module mapped;
28	MOT_BEARING	Bearing wear over limit	CIF-/IF-Module mapped;
29	MOT_TEMP_WARN	Pre alarm WSK	CIF-/IF-Module mapped;
30	MOD_TEMP_HI	Over temperature module	CIF-/IF-Module mapped; Stratos; IL_E, ...; MVIE, ...;
31	MOD_TEMP_COMP_HI	Over temperature power bridge / components	CIF-/IF-Module mapped; Stratos; IL_E, ...; MVIE, ...;
32	MOD_VOLT_DC_LO	Undervoltage DC link	CIF-/IF-Module mapped; IL_E, ...; MVIE, ...;
33	MOD_VOLT_DC_HI	Overvoltage DC link	CIF-/IF-Module mapped; IL_E, ...; MVIE, ...;
34	E034	Wrong combination pump - module	CIF-/IF-Module mapped;
35	E035	DP/MP: several same identity	CIF-/IF-Module mapped; IL_E, ...;
36	MOD_RELAY	Inrush current relay (Lader.) PFC defect (PFC) AD Converter (ADC) Synchronisation (Sync) Communication (Komm)	CIF-/IF-Module mapped; Stratos;
37	MOD_DC_LINK	DC link capacitor defect	CIF-/IF-Module mapped;
38	MOD_SENS_FLUID	PTC fluid defect	CIF-/IF-Module mapped; Stratos;

value	Name	description	support
39	E039	-	CIF-/IF-Module mapped;
40	SENS_PRESS	Ext. pressure sensor / switch defect	CIF-/IF-Module mapped;
41	SENS_ACC	Ext. acceleration sensor defect	CIF-/IF-Module mapped;
42	SENS_IN1	Connection to signal source at IN1 open loop / short circuit (2...10V/4...20mA)	CIF-/IF-Module mapped; MVIE, ...;
43	SENS_IN2	Connection to signal source at IN2 open loop / short circuit (2...10V/4...20mA)	CIF-/IF-Module mapped;
44	SENS_SPEED	Ext. Revolution speed sensor defect	CIF-/IF-Module mapped;
45	SENS_TEMP_1	Temperature sensor 1 defect	CIF-/IF-Module mapped;
46	SENS_TEMP_2	Temperature sensor 2 defect	CIF-/IF-Module mapped;
47	SENS_TEMP_3	Temperature sensor 3 defect	CIF-/IF-Module mapped;
48	E048	-	CIF-/IF-Module mapped;
49	E049	Expansion vessel / check valve	CIF-/IF-Module mapped;
50	COM_BMS	BMS-communication timeout	CIF-/IF-Module mapped; Stratos; IL_E, ...; MVIE, ...;
51	COM_DP	Not permitted combination DP/MP	CIF-/IF-Module mapped; Stratos; IL_E, ...;
52	COM_DP_TIMEOUT	DP/MP-communication timeout	CIF-/IF-Module mapped; Stratos; IL_E, ...;
53	COM_CAN_ADR	Double / multiple adress (for CAN bus communication)	CIF-/IF-Module mapped; Stratos;
54	COM_CAN_BIND	Binding not possible, bus device missing	CIF-/IF-Module mapped; Stratos; MVIE, ...;
55	COM_VFD	Frequency converter - communication error	CIF-/IF-Module mapped;
56	E056	-	CIF-/IF-Module mapped;
57	E057	-	CIF-/IF-Module mapped;
58	E058	-	CIF-/IF-Module mapped;
59	E059	-	CIF-/IF-Module mapped;
60	SYS_PRESS_HI	System over pressure	CIF-/IF-Module mapped;
61	SYS_PRESS_LO	System low pressure	CIF-/IF-Module mapped;
62	SYS_FLUID_LO	Lack of water (.x suffix for location)	CIF-/IF-Module mapped;
63	SYS_FLUID_LEAK	leakage in system (loss of water)	CIF-/IF-Module mapped;
64	SYS_FLUID_FROST	Frost protection	CIF-/IF-Module mapped;
65	SYS_FLUID_DRAIN	drainage failure	CIF-/IF-Module mapped;
66	SYS_FLUID_FLOOD	Flood (max. water level)	CIF-/IF-Module mapped;
67	SYS_OVD_FLUID_D	override of the standard discharge path (.x suffix for location)	CIF-/IF-Module mapped;
68	SYS_OVD_OFF	Priority off	CIF-/IF-Module mapped;
69	E069	-	CIF-/IF-Module mapped;
70	E070	Internal communication error	CIF-/IF-Module mapped; IL_E, ...; MVIE, ...;
71	E071	memory-error	CIF-/IF-Module mapped; IL_E, ...; MVIE, ...;
72	E072	Power components/ frequency converter	CIF-/IF-Module mapped; IL_E, ...; MVIE, ...;
73	E073	Frequency converter number	CIF-/IF-Module mapped;
74	E074	Internal fan defect	CIF-/IF-Module mapped;
75	E075	Inrush current relay defect	CIF-/IF-Module mapped; MVIE, ...;
76	E076	Current sensor defect	CIF-/IF-Module mapped; IL_E, ...;
77	E077	24V supply voltage defect	CIF-/IF-Module mapped; IL_E, ...;
78	E078	Unknown motor number	CIF-/IF-Module mapped;
79	E079	-	CIF-/IF-Module mapped;
80	PUMP_FAULT	Pump (collective fault)	CIF-/IF-Module mapped;
81	E081	Prealarm frequency converter (overtemperature, overload,...)	CIF-/IF-Module mapped;
82	E082	Frequency converter	CIF-/IF-Module mapped;
83	E083	-	CIF-/IF-Module mapped;
84	E084	-	CIF-/IF-Module mapped;
85	E085	-	CIF-/IF-Module mapped;

value	Name	description	support
86	E086	-	CIF-/IF-Module mapped;
87	E087	-	CIF-/IF-Module mapped;
88	E088	-	CIF-/IF-Module mapped;
89	MOT_MOD_FAULT	Motor or module fault	CIF-/IF-Module mapped;
90	E090	Implausible combination	CIF-/IF-Module mapped;
91	E091	-	CIF-/IF-Module mapped;
92	E092	-	CIF-/IF-Module mapped;
93	E093	-	CIF-/IF-Module mapped;
94	E094	-	CIF-/IF-Module mapped;
95	E095	-	CIF-/IF-Module mapped;
96	E096	Infobyte not set	CIF-/IF-Module mapped; IL_E, ...;
97	E097	Flexpump type data missing	CIF-/IF-Module mapped; IL_E, ...;
98	E098	Flexpump type data not valid (Checksum)	CIF-/IF-Module mapped; IL_E, ...;
99	E099	Pump type	CIF-/IF-Module mapped;
100	CTRL_BATT	Battery down	CIF-/IF-Module mapped;
101	PAN_TEMP_HI	Panel overtemperature	CIF-/IF-Module mapped;
102	PAN_TEMP_LO	Panel low temperature	CIF-/IF-Module mapped;
103	PAN_FAN_INT	Panel fan defect	CIF-/IF-Module mapped;
104	MOT_FAN_EXT	External fan motor defect	CIF-/IF-Module mapped;
105	CTRL_SHORT_CIRC	Control / power circuit short circuit (.x suffix for location)	CIF-/IF-Module mapped;
106	CTRL_OPEN_LOOP	Control / power circuit open loop (.x suffix for location)	CIF-/IF-Module mapped;
107	CTRL_ELEC_FAULT	Control / power circuit electrical fault (.x suffix for location)	CIF-/IF-Module mapped;
108	E108	Reserved block for controller faults	CIF-/IF-Module mapped;
109	CTRL_EXT_FAULT	external error	CIF-/IF-Module mapped;
110	E110	loss of sync	CIF-/IF-Module mapped;
111	E111	overcurrent	CIF-/IF-Module mapped;
112	E112	Motor speed higher than synchronous value	CIF-/IF-Module mapped;
113	E113		CIF-/IF-Module mapped;
114	E114		CIF-/IF-Module mapped;
115	E115		CIF-/IF-Module mapped;
116	E116		CIF-/IF-Module mapped;
117	E117		CIF-/IF-Module mapped;
118	E118		CIF-/IF-Module mapped;
119	MOT_TURBINE	turbine driven	CIF-/IF-Module mapped;
120	E120	Reserved	CIF-/IF-Module mapped;
121	E121	Sensor error motor PTC short circuit	CIF-/IF-Module mapped;
122	E122	Sensor error hybrid module open loop	CIF-/IF-Module mapped;
123	E123	Sensor error hybrid module short circuit	CIF-/IF-Module mapped;
124	E124	sensor error electronics open loop	CIF-/IF-Module mapped;
125	E125	sensor error electronics short circuit	CIF-/IF-Module mapped;
126	E126		CIF-/IF-Module mapped;
127	E127		CIF-/IF-Module mapped;
128	E128		CIF-/IF-Module mapped;
129	E129		CIF-/IF-Module mapped;
130	ENG_FUEL	fuel level low	CIF-/IF-Module mapped;
131	ENG_PREHEAT	preheating engine	CIF-/IF-Module mapped;
132	ENG_PRESS_OIL_LO	oil pressure	CIF-/IF-Module mapped;
133	ENG_TEMP_HI	overtemperature motor	CIF-/IF-Module mapped;
134	E134		CIF-/IF-Module mapped;
135	E135		CIF-/IF-Module mapped;
136	E136		CIF-/IF-Module mapped;
137	ENG_DRIVE_BELT	drive belt	CIF-/IF-Module mapped;
138	ENG_FLUID_LO	Cooling liquid level motor	CIF-/IF-Module mapped;
139	E139		CIF-/IF-Module mapped;

value	Name	description	support
140	E140	Monitoring switching frequency	CIF-/IF-Module mapped;
141	E141	Monitoring of runtime	CIF-/IF-Module mapped;
142	E142		CIF-/IF-Module mapped;
143	E143		CIF-/IF-Module mapped;
144	E144		CIF-/IF-Module mapped;
145	E145		CIF-/IF-Module mapped;
146	E146		CIF-/IF-Module mapped;
147	E147		CIF-/IF-Module mapped;
148	E148		CIF-/IF-Module mapped;
149	E149		CIF-/IF-Module mapped;
150	E150		CIF-/IF-Module mapped;
151	E151		CIF-/IF-Module mapped;
152	E152		CIF-/IF-Module mapped;
153	E153		CIF-/IF-Module mapped;
154	E154		CIF-/IF-Module mapped;
155	E155		CIF-/IF-Module mapped;
156	E156		CIF-/IF-Module mapped;
157	E157		CIF-/IF-Module mapped;
158	E158		CIF-/IF-Module mapped;
159	E159		CIF-/IF-Module mapped;
160	E160		CIF-/IF-Module mapped;
161	E161		CIF-/IF-Module mapped;
162	E162		CIF-/IF-Module mapped;
163	E163		CIF-/IF-Module mapped;
164	E164		CIF-/IF-Module mapped;
165	E165		CIF-/IF-Module mapped;
166	E166		CIF-/IF-Module mapped;
167	E167		CIF-/IF-Module mapped;
168	E168		CIF-/IF-Module mapped;
169	E169		CIF-/IF-Module mapped;
170	E170		CIF-/IF-Module mapped;
171	E171		CIF-/IF-Module mapped;
172	E172		CIF-/IF-Module mapped;
173	E173		CIF-/IF-Module mapped;
174	E174		CIF-/IF-Module mapped;
175	E175		CIF-/IF-Module mapped;
176	E176		CIF-/IF-Module mapped;
177	E177		CIF-/IF-Module mapped;
178	E178		CIF-/IF-Module mapped;
179	E179		CIF-/IF-Module mapped;
180	E180		CIF-/IF-Module mapped;
181	E181		CIF-/IF-Module mapped;
182	E182		CIF-/IF-Module mapped;
183	E183		CIF-/IF-Module mapped;
184	E184		CIF-/IF-Module mapped;
185	E185		CIF-/IF-Module mapped;
186	E186		CIF-/IF-Module mapped;
187	E187		CIF-/IF-Module mapped;
188	E188		CIF-/IF-Module mapped;
189	E189		CIF-/IF-Module mapped;
190	E190		CIF-/IF-Module mapped;
191	E191		CIF-/IF-Module mapped;
192	E192		CIF-/IF-Module mapped;
193	E193		CIF-/IF-Module mapped;
194	E194		CIF-/IF-Module mapped;
195	E195		CIF-/IF-Module mapped;
196	E196		CIF-/IF-Module mapped;
197	E197		CIF-/IF-Module mapped;
198	E198		CIF-/IF-Module mapped;
199	E199		CIF-/IF-Module mapped;

value	Name	description	support
200	SIM_A	Error type A (simulated)	CIF-/IF-Module mapped;
201	SIM_B	Error type B (simulated)	CIF-/IF-Module mapped;
202	SIM_C	Error type C (simulated)	CIF-/IF-Module mapped;
203	SIM_D	Error type D (simulated)	CIF-/IF-Module mapped;
204	SIM_E	Error type E (simulated)	CIF-/IF-Module mapped;
205	SIM_F	Warning type F (simulated)	CIF-/IF-Module mapped;
206	E206		CIF-/IF-Module mapped;
207	E207		CIF-/IF-Module mapped;
208	E208		CIF-/IF-Module mapped;
209	E209		CIF-/IF-Module mapped;
210	E210		CIF-/IF-Module mapped;
211	E211		CIF-/IF-Module mapped;
212	E212		CIF-/IF-Module mapped;
213	E213		CIF-/IF-Module mapped;
214	E214		CIF-/IF-Module mapped;
215	E215		CIF-/IF-Module mapped;
216	E216		CIF-/IF-Module mapped;
217	E217		CIF-/IF-Module mapped;
218	E218		CIF-/IF-Module mapped;
219	E219		CIF-/IF-Module mapped;
220	E220		CIF-/IF-Module mapped;
221	E221		CIF-/IF-Module mapped;
222	E222		CIF-/IF-Module mapped;
223	E223		CIF-/IF-Module mapped;
224	E224		CIF-/IF-Module mapped;
225	E225		CIF-/IF-Module mapped;
226	E226		CIF-/IF-Module mapped;
227	E227		CIF-/IF-Module mapped;
228	E228		CIF-/IF-Module mapped;
229	E229		CIF-/IF-Module mapped;
230	E230		CIF-/IF-Module mapped;
231	E231		CIF-/IF-Module mapped;
232	E232		CIF-/IF-Module mapped;
233	E233		CIF-/IF-Module mapped;
234	E234		CIF-/IF-Module mapped;
235	E235		CIF-/IF-Module mapped;
236	E236		CIF-/IF-Module mapped;
237	E237		CIF-/IF-Module mapped;
238	E238		CIF-/IF-Module mapped;
239	E239		CIF-/IF-Module mapped;
240	E240		CIF-/IF-Module mapped;
241	E241		CIF-/IF-Module mapped;
242	E242		CIF-/IF-Module mapped;
243	E243		CIF-/IF-Module mapped;
244	E244		CIF-/IF-Module mapped;
245	E245		CIF-/IF-Module mapped;
246	E246		CIF-/IF-Module mapped;
247	E247		CIF-/IF-Module mapped;
248	E248		CIF-/IF-Module mapped;
249	E249		CIF-/IF-Module mapped;
250	E250		CIF-/IF-Module mapped;
251	E251		CIF-/IF-Module mapped;
252	E252		CIF-/IF-Module mapped;
253	EXTENDED	extended code	CIF-/IF-Module mapped;
254	UNDEFINED	undefined error	CIF-/IF-Module mapped;
255	INVALID	invalid error	CIF-/IF-Module mapped;

This is the base signal. The current warning or error can be read out here. It is the WILO error code where the different codes can be found in the pump manual.

Support reference: Stratos; IL_E, ...; MVIE, ...;

7 Installation and electrical connection

Installation and electrical connection must be carried out in accordance with local regulations and only by qualified personnel.



WARNING! Risk of personal injury! The existing directives for accident prevention must be adhered to.



DANGER! Risk of fatal electrical shock!

Danger from electrical current must be eliminated. Local directives or general directives [e.g. IEC, VDE etc.] and those of local power supply companies must be adhered to.

7.1 Installation

The mounting of the CIF-modules for other pump types is described in the pump manual.

To ensure immunity in industrial environments (EN 61000-6-2) the data cables must be shielded cables and must be used with an EMC-compliant cable gland (included with the module, if necessary). Shield shall be connected to earth on both ends.

For optimal transmission with BACnet MS/TP, CANopen or Modbus RTU, the data cable pair should be twisted and have a characteristic impedance of 120 Ω .



DANGER! Risk of fatal electrical shock!

- Isolate the power supply and secure against unauthorised switch-on before all operations.
- Work on the module may only be started once 5 minutes have passed, due to the dangerous residual contact voltage.
- Check to ensure that all connections (including potential-free contacts) are voltage-free

Electrical connection follows (see section below).

7.2 Electrical connection



DANGER! Risk of fatal electrical shock!

Electrical connection must be carried out by an electrician authorised by the local electricity supply company and in accordance with the applicable local regulations [e.g. VDE regulations].

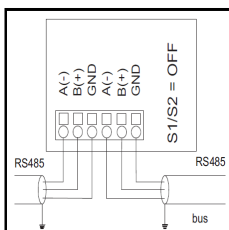

Figure 7.2.1 wiring in line RS485

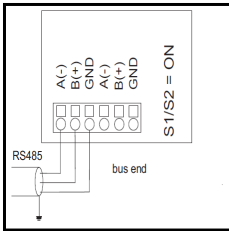

Figure 7.2.2 wiring end of line RS485

- Carry out installation as described in the previous section
- Carry out electrical installation of the pump as specified in the relevant installation and operating instructions
- Check the technical specifications of the electric circuits being connected to ensure that they are compatible with the electrical specifications of the CIF-Module
- Connect the wires according the appropriate figure above.
- Set BUS terminating resistors (both switches "ON") for RS485 / CAN, if there is no outgoing line
- Check the terminal box seal for any visible damage
- Close the terminal box lid with the screws provided so that the seal is tight all around
- Carry out commissioning / functional test in accordance with the following main section

The terminals of the CIF-modules with RS485 are marked with A(-) and B(+). The marking complies with the RS485 standard. Nevertheless some manufacturers of automation equipment are using the opposite marking of A and B. This may cause communication issues.

RS485 does not allow any loops, star connections or stub lines. All devices shall be daisy chained.

8 Commissioning/functional test

The following sections describe the test of the input/output functionality. It is recommended to test together with the connected system. The pump's installation and operating instructions are needed for some settings.

8.2 Settings

8.2.1 General

The settings for the CIF-modules can be found at Settings/External interfaces/

8.2.2 Bus Address

Set the bus address in the pump menu .

OFF deactivates the interface.

8.2.3 Transmission speed (baud rate)

(Parameter A)	Speed Bit/s
0	300
1	600
2	1200
3	2400
4	4800
5	9600
6	19200
7	38400
8	57300
9	115200
10	76800

fig. 8.2.3.1: transmission speed

8.2.4 Parameter C - data frame

Modbus RTU defines a frame with 8 data bytes, a parity bit and one or two stop bits. The parity bit can be either even (E), odd (O) or no parity (N). The following options are available:

(Parameter C)	format
2	8,N,1
3	8,N,2
6	8,E,1
10	8,O,1

fig. 8.2.4.1: frame setting

All other values are reserved and shall not be used.

8.2.7 Fieldbus configuration "read only"

When using CIF-Modules, the local menu is active in the states MANUAL or MANUAL PRESET of the datapoint bus command timer. In these states, it is not necessary to write settings from fieldbus.

8.3 Functional test / basic example

The following setup sequence shows a basic setting for the CIF-Modbus. the <a.b.c.d.e> indicate the menu numbers (not Stratos). For Stratos the menu is described in the text.

- Setup your Modbus Master to RTU, 9600 Baud, 8/N/1 frame, our slave address will be 1
- Read the input register 700 (30701) with your Modbus master: read shall be successful (you do not have an offset issue). if not ok, try 699/701 to detect potential register offset between the systems (has to be respected subsequently).
- Write value 1 to holding register 300 (40301) (bus command timer OFF)
- Write value 1 to holding register 42 (40043) (operation mode fixed speed)
- Write value 200 to holding register 1 (40002) (setvalue 100 %)
- Write value 9 to holding register 40 (40041) (pump command ON)
- The pump shall start and run at nominal speed

Below please find a snapshot for this communication example (M- Modbus Master S- Slave (the pump)):

```

01 04 02 BC 00 01 F1 96      M: 04-Rd_InputReg ID#2 Rd 30701, 1
01 04 02 02 00 B8 50        S: 04-Rd_InputReg ID#2 cnt=2, Rd 30701=512 (0x0200) // software version 2.00
01 06 01 2C 00 01 88 3F      M: 06-Wr_SHoldReg ID#3 Wr 40301=1 (0x0001)
01 06 01 2C 00 01 88 3F      s: 06-Wr_SHoldReg ID#3 Wr 40301=1 (0x0001)
01 06 00 2A 00 01 69 C2      M: 06-Wr_SHoldReg ID#4 Wr 40043=1 (0x0001)
01 06 00 2A 00 01 69 C2      s: 06-Wr_SHoldReg ID#4 Wr 40043=1 (0x0001)
01 06 00 01 00 C8 D9 9C      M: 06-Wr_SHoldReg ID#5 Wr 40002=200 (0x00C8)
01 06 00 01 00 C8 D9 9C      s: 06-Wr_SHoldReg ID#5 Wr 40002=200 (0x00C8)
01 06 00 28 00 09 C9 C4      M: 06-Wr_SHoldReg ID#6 Wr 40041=9 (0x0009)
01 06 00 28 00 09 C9 C4      s: 06-Wr_SHoldReg ID#6 Wr 40041=9 (0x0009)

```

9 Maintenance

The modules described in these instructions are maintenance-free.

10 Faults, causes and remedies

Have repairs done by qualified skilled personnel only!



DANGER! Danger of electric shock! Any danger from electrical current should be ruled out.



WARNING! Risk of scalding! At high fluid temperatures and system pressures, allow the pump to cool down first and then depressurise the system.

- The pump should be electrically isolated and secured against unauthorised switch-on prior to any repair work.
- Damage to the mains connection cables shall always be repaired by a qualified electrician only.

Faults	Causes	Remedy
Communication with external control is disrupted	Wrong communication parameter(s)	Check, and adjust if necessary (see Commissioning)
	Damaged wiring	Check whether other bus nodes are affected in order to find position of missing connection
Flow value inaccurate	Viscosity of fluid changed by additives	
Setpoint is not reached	Pump is at power or speed limit	Reduce setpoint

Fig. 10.1: Errors / causes / remedies

If the operating fault cannot be remedied, please consult a specialist technician or the nearest Wilo after-sales service point or representative.

10.1 Status information vs Wilo E-codes

The following table shows the status information which is given corresponding to the Wilo E-code

name	error_code
Status Undervoltage	4
Status Overvoltage	5
Status Phase fault	6
Status Idle running	11
Status Motor overheated	20
Status Motor error	16,21,23,24,25,26,89
Status Pump blocked	10,12
Status Module overheated	30,31
Status Module warning	34,51,52
Status Module error	36,37,50,89
Status sensor malfunction	26,27,38,40,41,42
Error Present	10,20,21,23,24,25,26,30,31,36,70,71,72,73,74,75,76,77,78,89,96,97,98
Status supply voltage error	4,5,6
Service Required	10,12,16,21,23,24,25,26,27,34,36,37,38,40,41,42,50,52
Warning Present	3,4,5,6,7,11,32,33,35,42,50,51,52,53,54

Fig. 10.1.1: Status vs E codes

11 Spare Parts

Spare parts may be ordered via a local specialist retailer and/or Wilo customer service.

To avoid queries and incorrect orders, all data on the type plate of the CIF-Module and the device where it is mounted should be submitted with each order.

12 Disposal

Information about collection of used electric and electronic products

Proper disposal and recycling of this product prevents damage to the environment and risks to personal health.



NOTE: Prohibition of disposal with domestic garbage!



Within the European Union, this symbol may appear on the product, the package or on related documents. It means that the affected electric and electronic products shall not be disposed with the household garbage. For a proper treatment, recycling and disposal respect the following topics:

- Dispose these products at certified collection points.
- Respect local regulations!

Request for information about proper disposal at local authorities, local waste collection points or at your dealer. Further information at

[WILO Recycling \(http://www.wilo-recycling.com/\)](http://www.wilo-recycling.com/)

Product specifications are subject to change without prior notice!

WILO SE

Nortkirchenstr. 100

D-44263 Dortmund

Germany

[T +49 231 4102-0 \(tel:+4923141020\)](tel:+4923141020)

[F +49 231 4102-7363 \(tel:+4923141027363\)](tel:+4923141027363)

2019-08-02

[WILO Automation \(http://www.wilo.com/automation\)](http://www.wilo.com/automation)