

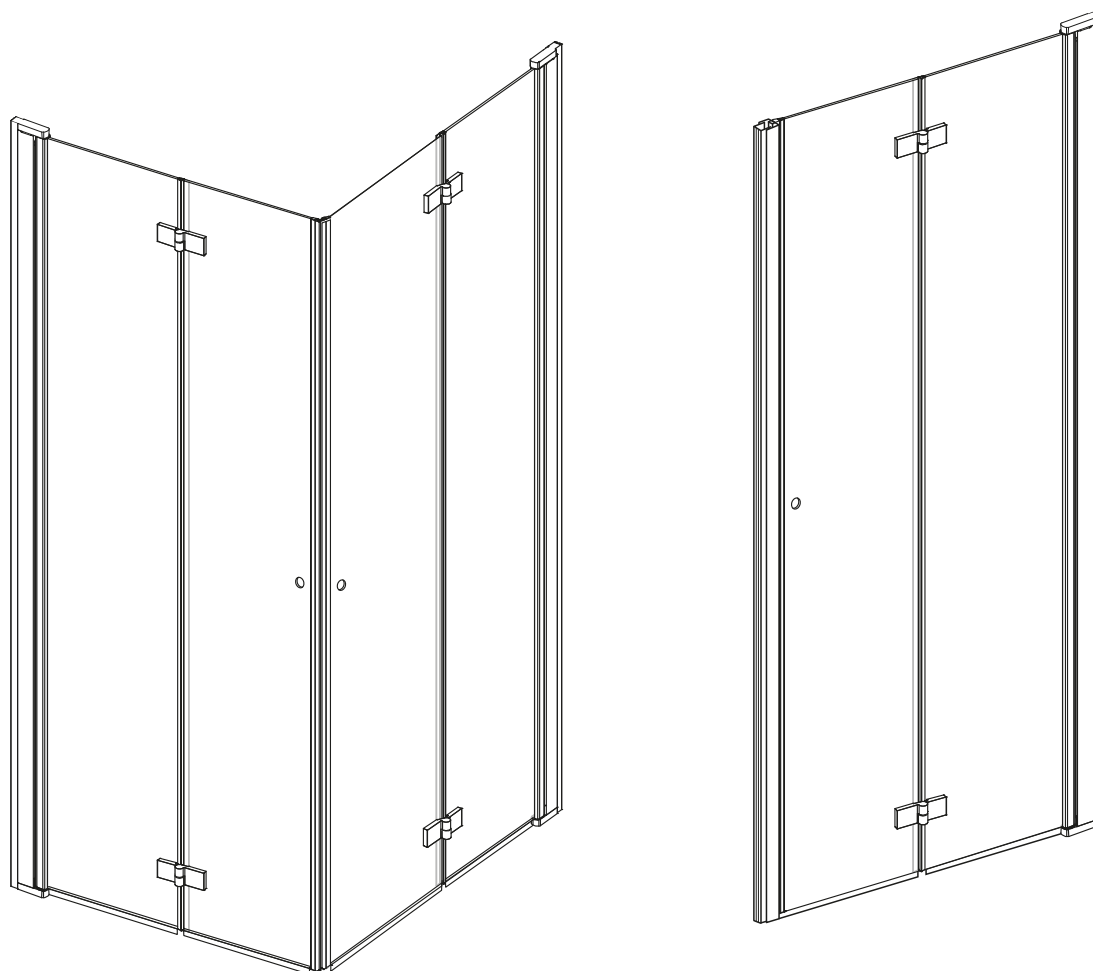

- SE MONTERINGSANVISNING SQUARE VIKDÖRR FÖR HÖRN & NISCHMONTAGE
- DK MONTERINGSANVISNING SQUARE FOLDEDØR TIL HJØRNE- OG NICHEMONTERING
- NO MONTERINGSANVISNING FIRKANTET FOLDEDØR FOR HJØRNE- OG NISJEMONTERING.
- FI ASENNUSOHJE SQUARE/ KÄÄNTYVÄ SUIHKUOVI NURKKAAN TAI SYVENNYKSEEN
- GB INSTALLATION INSTRUCTION SQUARE FOLDING DOOR FOR CORNER AND NICHE INSTALLATION
- EE PAIGALDUSJUHEND SQUARE NURGA- JA NIŠIPAIGALDUSEGA VOLDIK DUŠIUSTELE
- LV UZSTĀDĪŠANAS INSTRUKCIJA, KVADRĀTA/APAĻAS UN NIŠAS DURVIS
- LT MONTAVIMO INSTRUKCIJA KVADRATINĖS/PUSAPVALĖS DUŠO DURYS IR DUŠO DURYS MONTAVIMUI Į NIŠĄ









CE



Accepterad  
monteringsanvisning  
2026:1



	Garanti. Takuu. Guarantee. Garantii. Garantija. Garantija.	2/20		4/20. 13-19/20	
		3/20		Reservdelar. Reservedeler. Reservele. Varaosat. Spare parts. Varuosad. Atsarginės dalys. Rezerves daļas.	20/20
		5/20. 20/20		Drift & skötsel Drift og vedligeholdelse Drift og vedlikehold Asennus-, käyttö- ja hoito-ohjeet Assembly and maintenance Paigaldamine & hooldamine Montaza un kopsana Montavimas ir priežiūra	20/20
		3/20. 6-12/20			

## SE GARANTI

Produkten har garanti enligt respektive lands gällande branschvillkor.

Direktiv vid reklamation.

Våra produkter är tillverkade enligt väldigt stränga kvalitetskrav. Om en produkt trots det är felaktig, ber vi er i första hand att kontakta din återförsäljare. Ärendet underlättas genom att uppvisa kvitto och uppge produktnummer och inköpsdatum.

## DK GARANTI

Produktet har garanti i forhold til gældende dansk lovgivning.

Vejledning ved reklamation.

Vores produkter er fremstillet i overensstemmelse med markedets strengeste krav til kvalitet. Skulle produktet mod forventning være behæftet med fejl henviser vi til den forhandler, hvor produktet er købt. Kvittering skal kunne fremvises, hvis forhandleren forlanger det, ligesom oplysninger om produktnummer og købsdato skal kunne dokumenteres.

## NO GARANTI

Produktene har garanti i henhold til respektive lands gjeldende bransjevilkår.

Instruksjer ved reklamasjon.

Våre produkter er produsert i overensstemmelse med markeds strengeste kvalitetskrav. Om et produkt til tross for dette skulle være feilaktig, ber vi deg vennligst ta kontakt med forhandleren. Vi ber deg medbringe kvittering og oppgi innkjøpsdato samt produktnummer.

## FI TAKUU

Noudatamme alamme yleisiä toimitusehtoja.

Reklamaatio.

Tuotteemme ovat valmistettu Villeroy & Boch ja Gustavsbergin laatuvaatimuksien mukaisesti. Mikäli tuote kuitenkin on virheellinen pyydämme teitä kääntymään ensisijaisesti tuotteen myyjän puoleen. Käsittelyn helpottamiseksi säilyttäkää tosite tuotteen ostosta.

## GB GUARANTEE

The product has a guarantee accordingly to industry rules in every country.

Instructions for complaints.

Our products are made according to very strict quality demands. If the product is faulty in spite of that we ask you kindly to take it to your retailer. We also ask you to bring the receipt and be prepared to inform about the product number and purchasing date.

## EE GARANTII

Antud tootel on garantii vastavalt tehase poolt kehtestatud tingimustele.

Juhised reklamatsioonide käsitlemiseks.

Meie tooted on valmistatud silmas pidades väga täpseid kvaliteedistandardeid. Juhul kui olete saanud praaktoote, palume Teil toimetada see kas meie edasimüüja juurde või võtta ühendust esindusega. Samuti palume alles hoida ostušekk ning vajadusel anda informatsiooni tootenumbril ja ostu sooritamise aja kohta.

## LV GARANTIJA

Izstrādājumam ir garantija saskaņā ar ražotāja standartiem.

Instrukcija kvalitātes problēmu gadījumā.

Mūsu produkcija tiek ražota pēc ļoti striktiem kvalitātes kritērijiem. Taču – gadījumā, ja produktam tiek konstatēta kvalitātes problēma – lūdz, sazinieties ar pārdevēju. Lūdz, esiet gatavi arī uzrādīt pirkuma čeku ar pirkuma datumu.

## LT GARANTIJA

Gaminiams garantija suteikiama atsizvelgiant į , konkrečios šalies kokybės reikalavimus.

Reklamacijos.

Mū su , produkcija pagaminta vadovaujantis griežtais kokybės reikalavimais. Jei gaminys nekokybiškas – prašome jį , gražinti pardavėjui, pateikiant pirkimo čekį , , gaminio numerį bei nurodant pirkimo datą , .

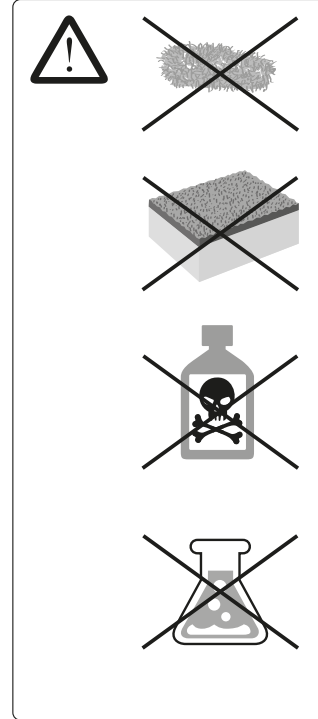
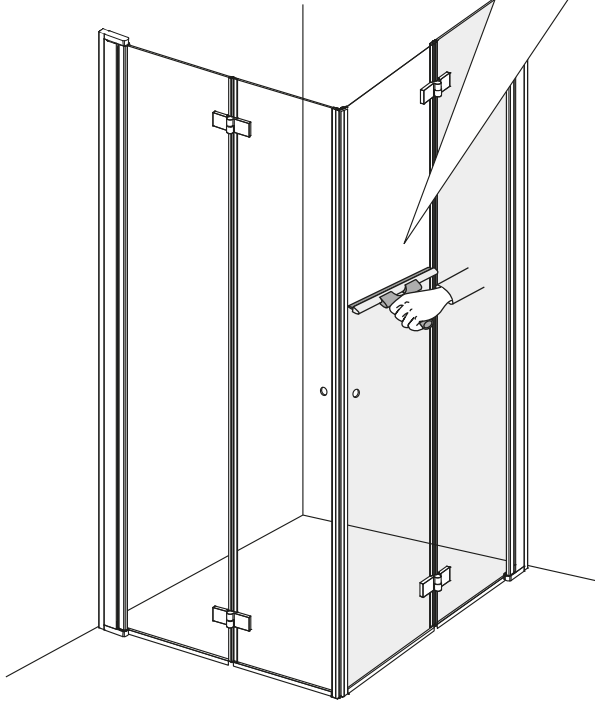
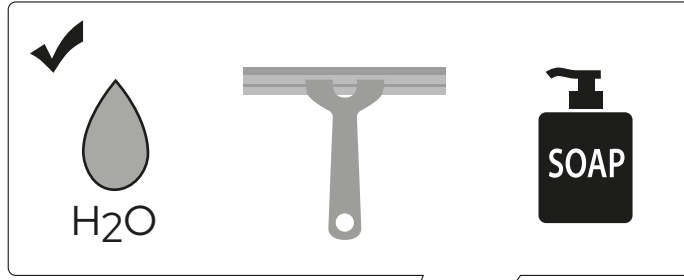

SQUARE

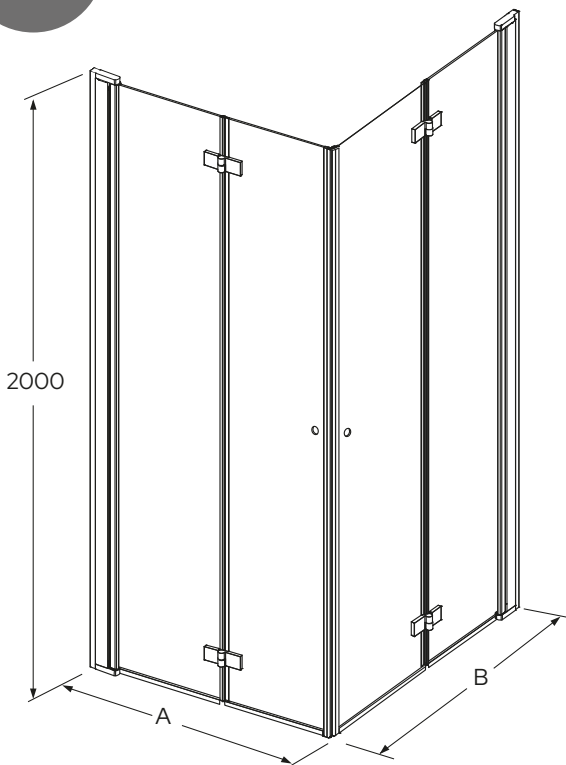

	A:	B:
800 x 800	790-810	790-810
900 x 900	890-910	890-910
1000 x 1000	990-1010	990-1010



## NICHE LEFT

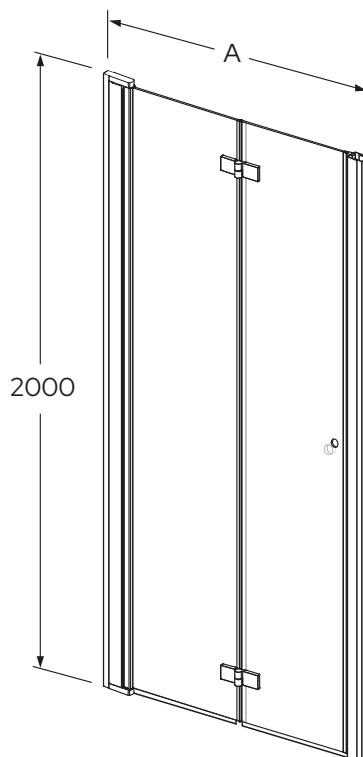

	A:
800 x 800	802-827
900 x 900	902-927
1000 x 1000	1002-1027



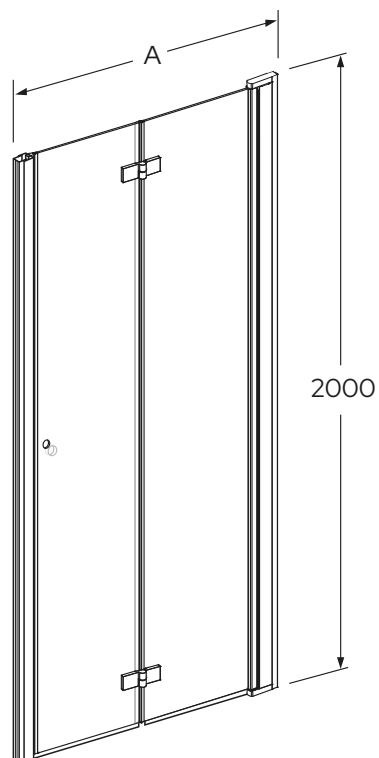

## NICHE RIGHT



	A:
800 x 800	802-827
900 x 900	902-927
1000 x 1000	1002-1027



  SE. Enligt Branschregler  
Säker Vatteninstallation

Kraven på infästning och tätning gäller i våtzone. Alla skruvinfästningar ska göras i massiv konstruktion, t ex i betong, i reglar eller särskild konstruktionsdetalj. Skruvinfästningar får inte göras enbart i golv- eller väggskiva.

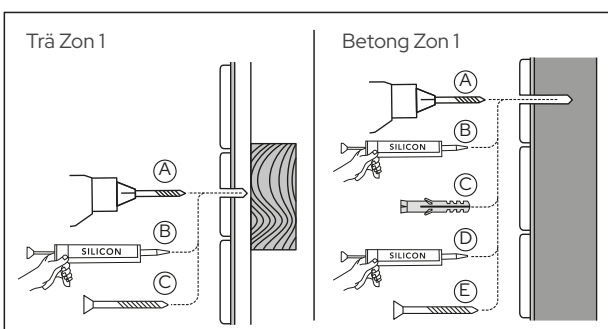
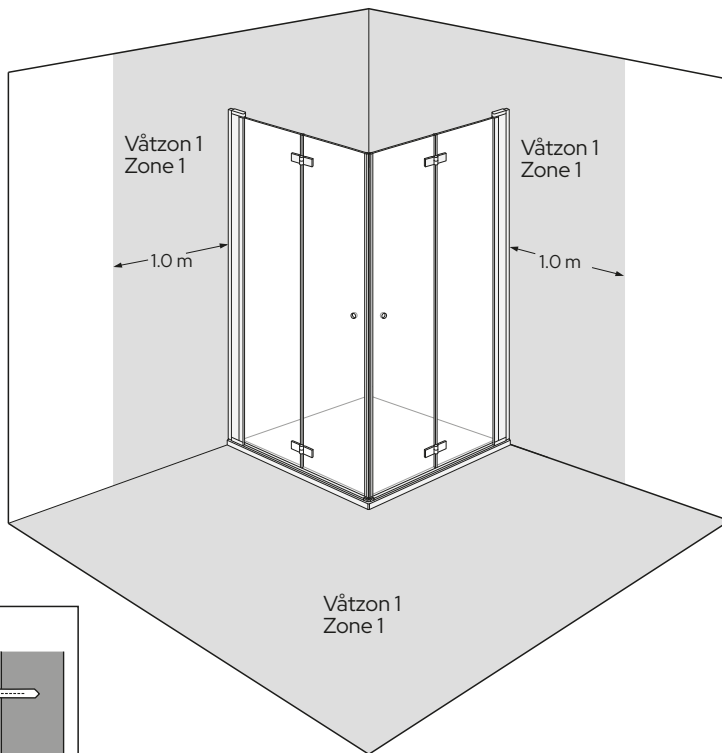

## SQUARE / NICHE

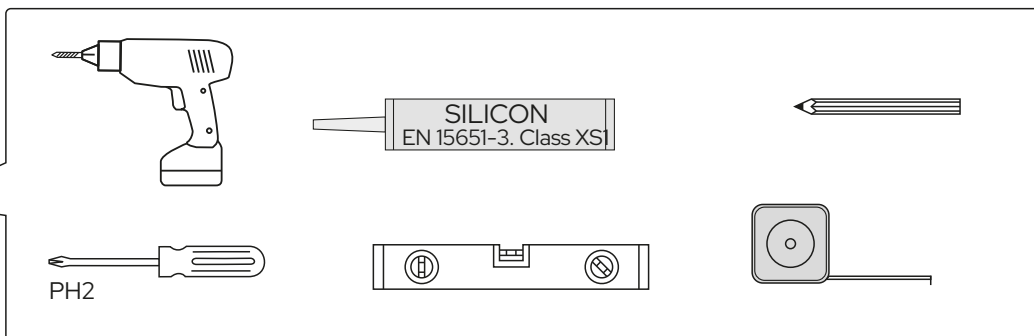
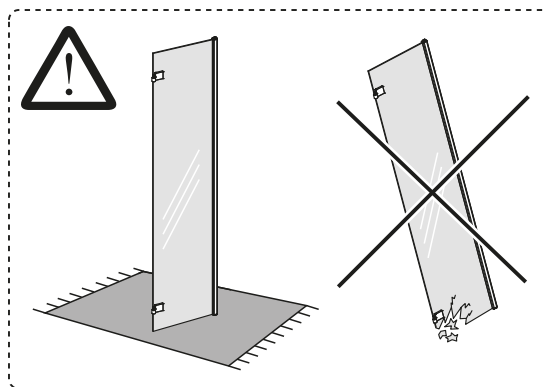
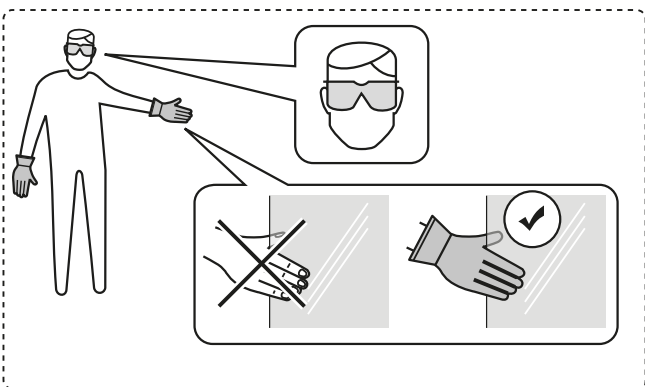



# SQUARE

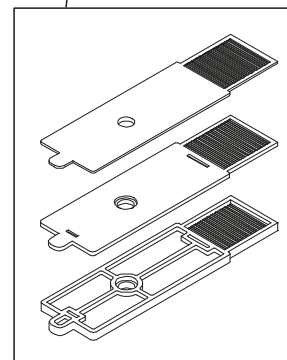
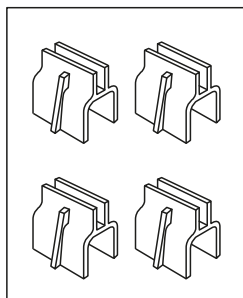
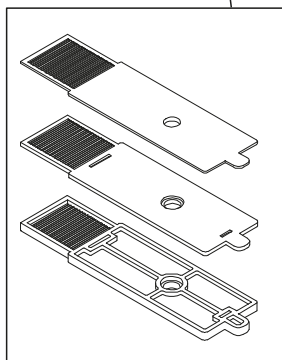
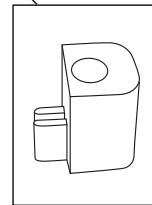
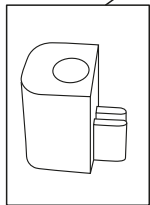
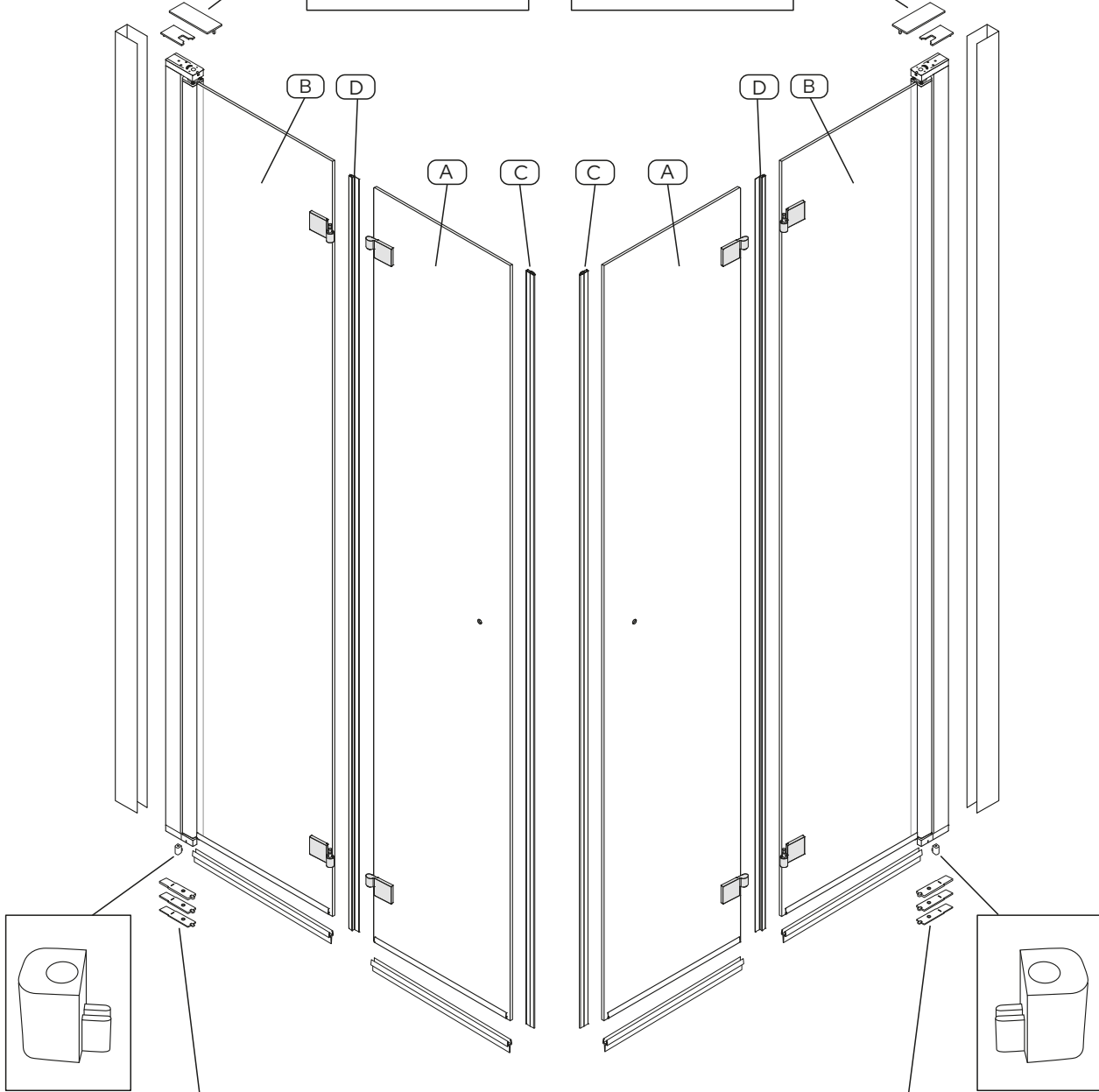
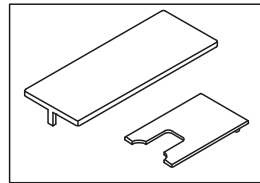
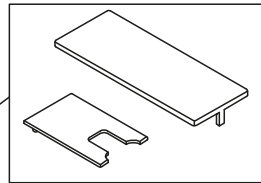
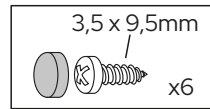
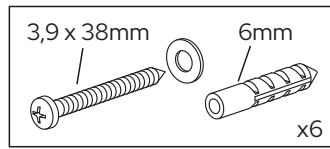
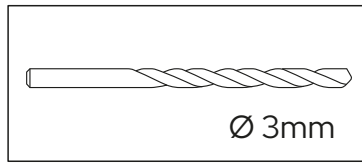



# SQUARE

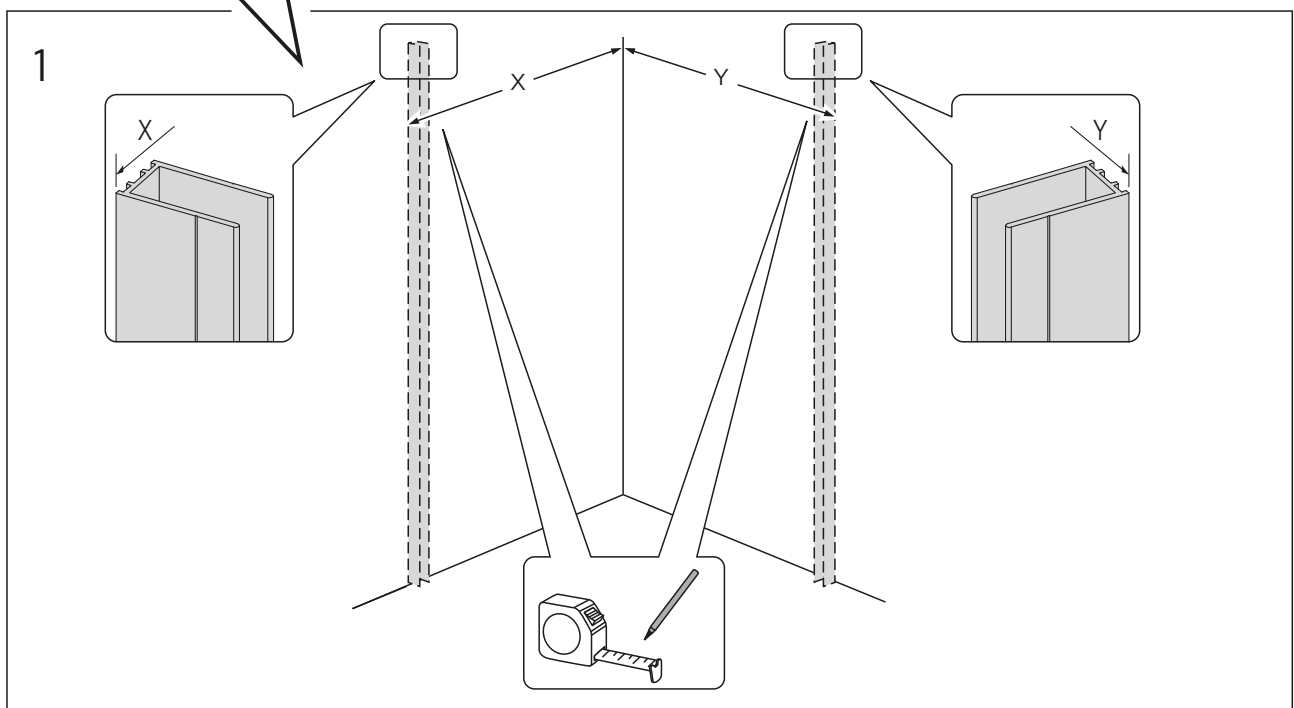
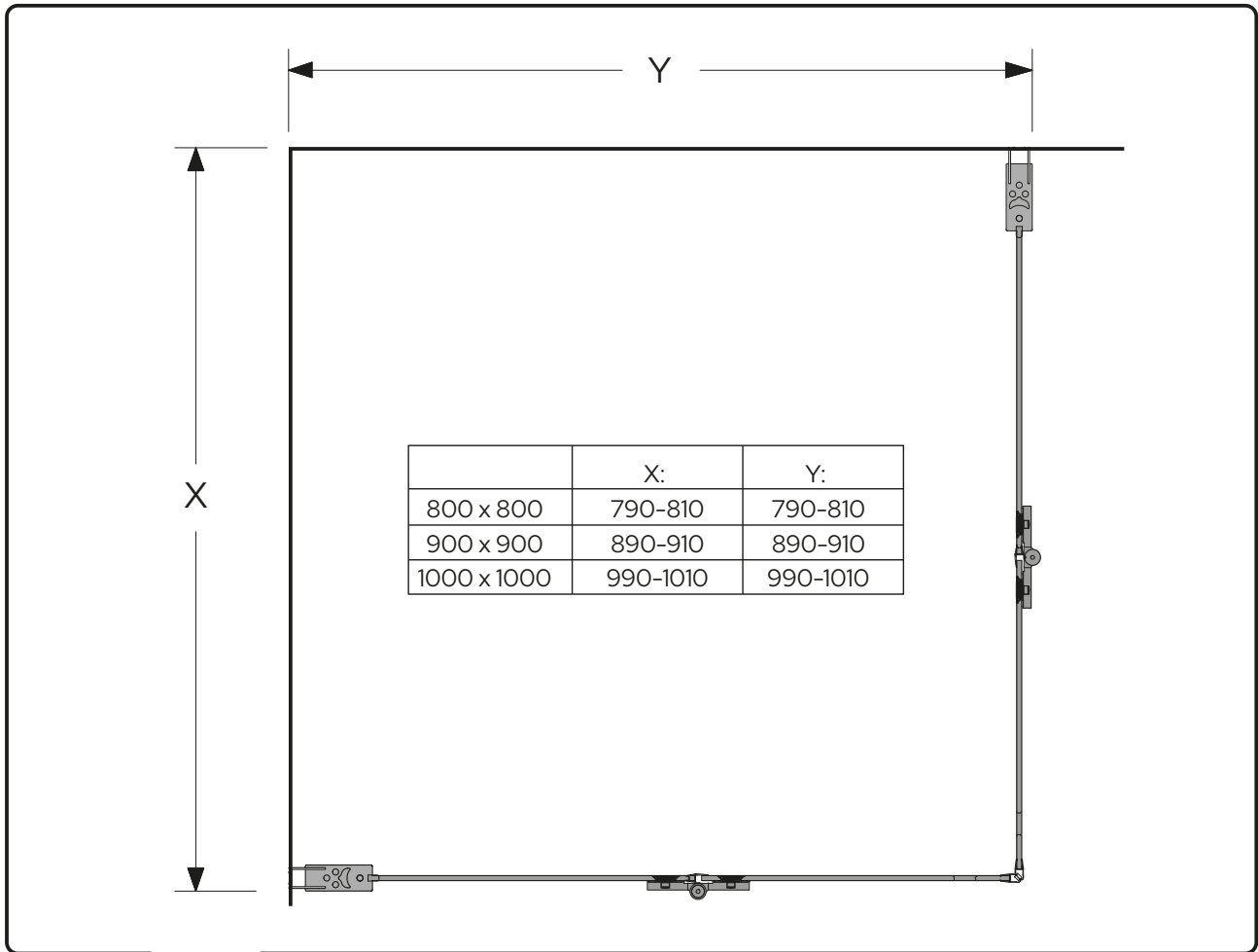

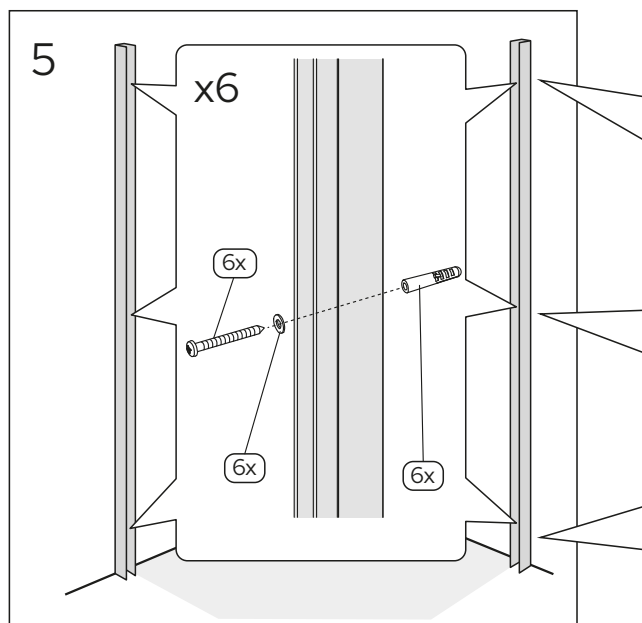
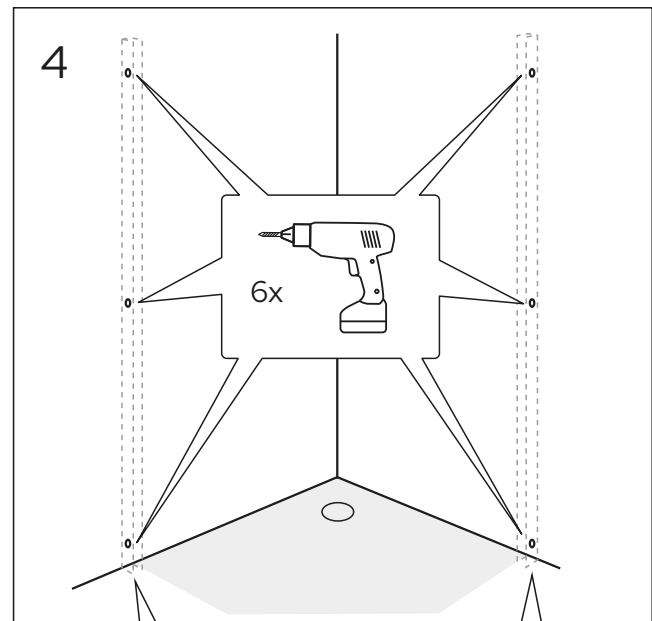
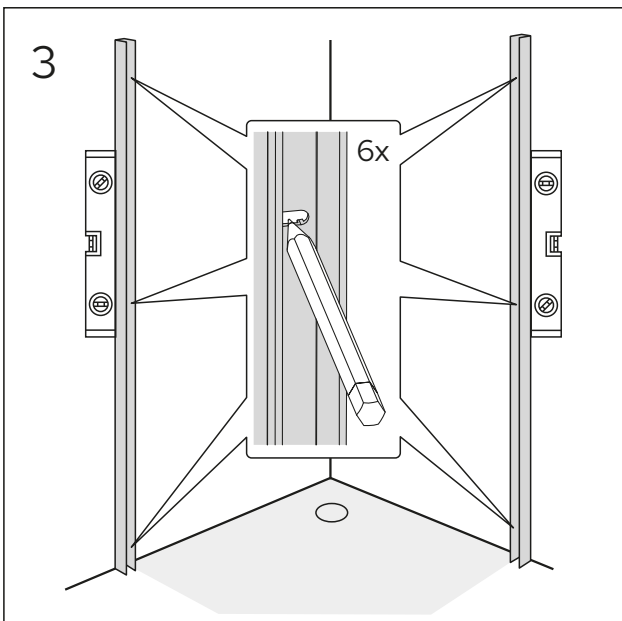
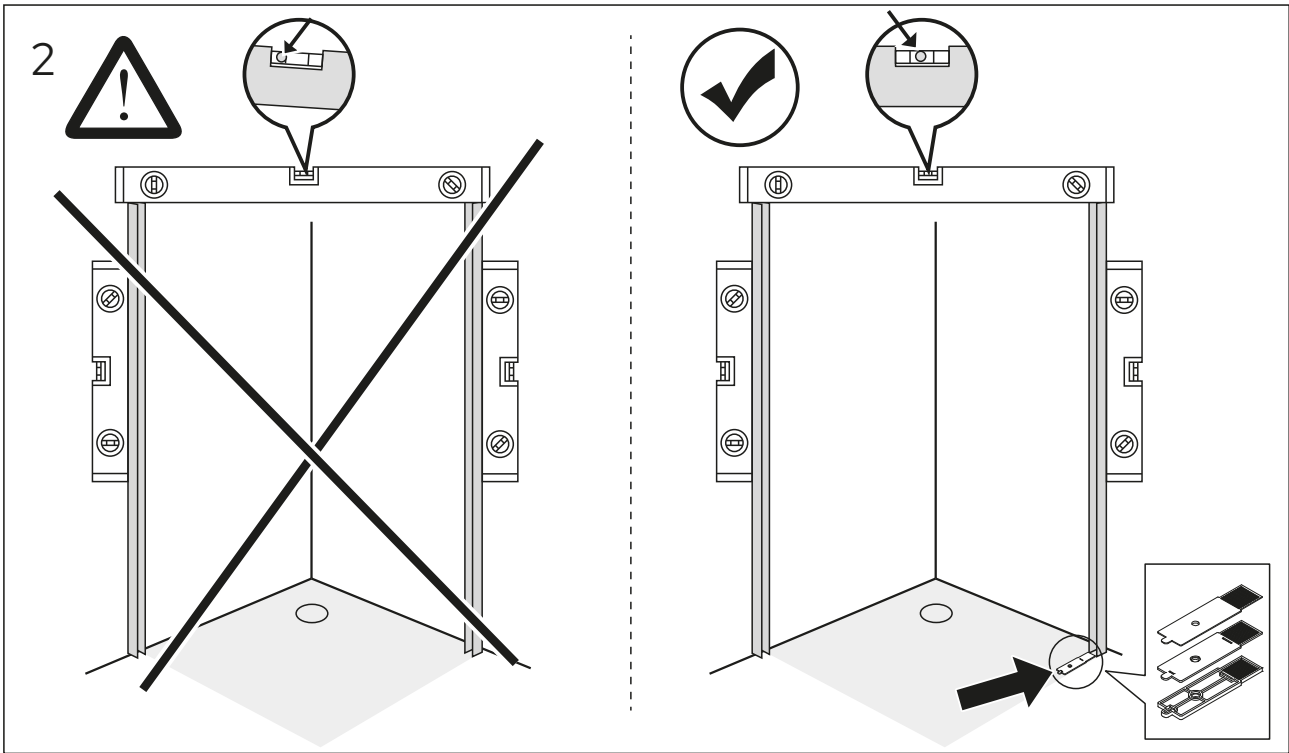

SE. Enligt Branschregler  
Säker Vatteninstallation

Kraven på infästning och tätning gäller i våtzon.  
Alla skruvinfästningar ska göras i massiv  
konstruktion, t ex i betong, i reglar eller särskild  
konstruktionsdetalj. Skruv- infästningar får inte  
göras enbart i golv- eller väggskiva.

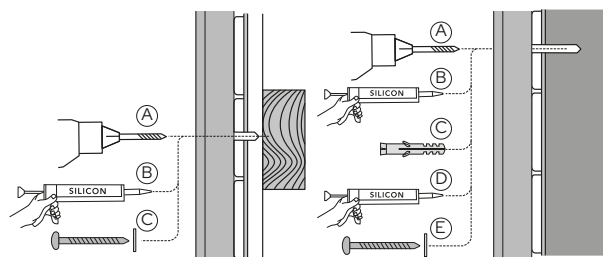

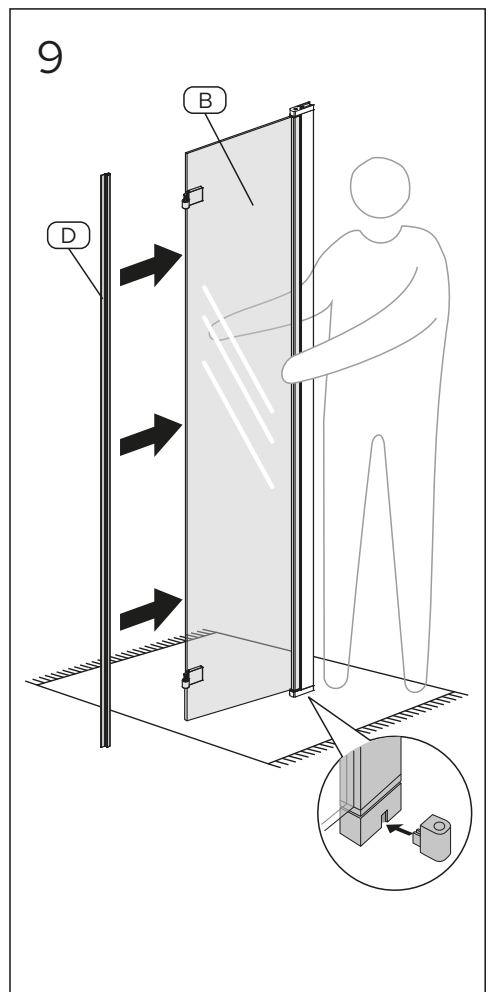
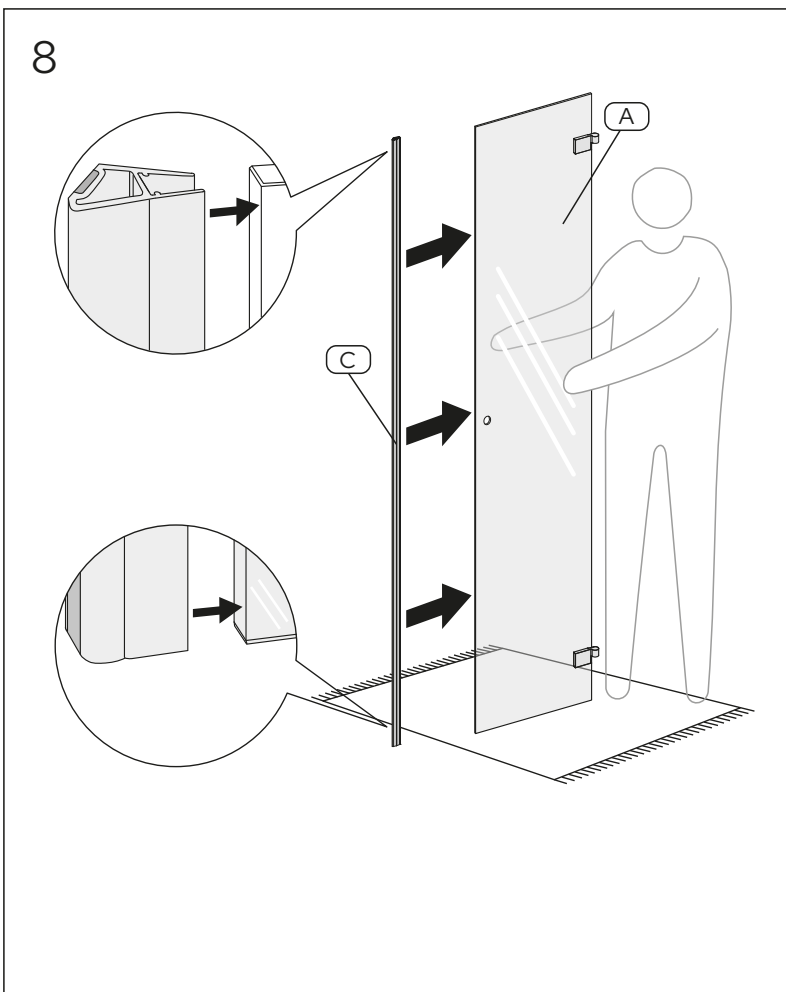
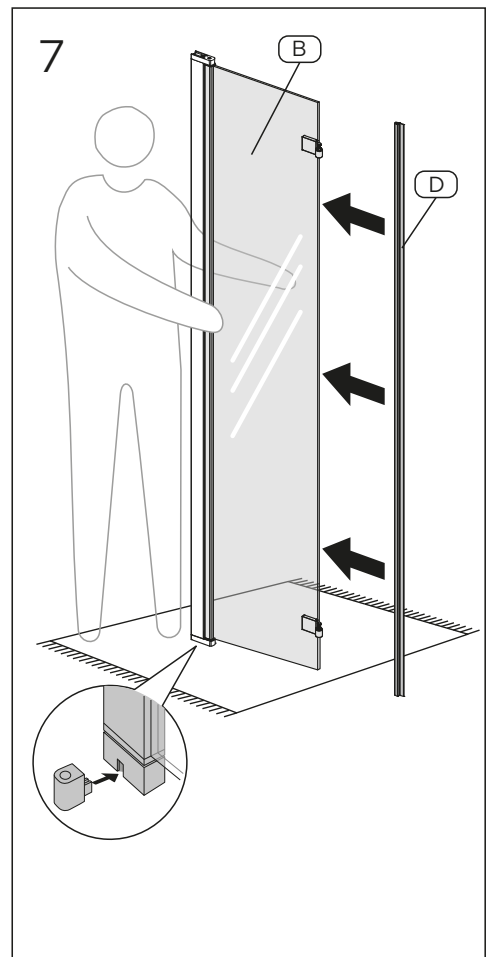
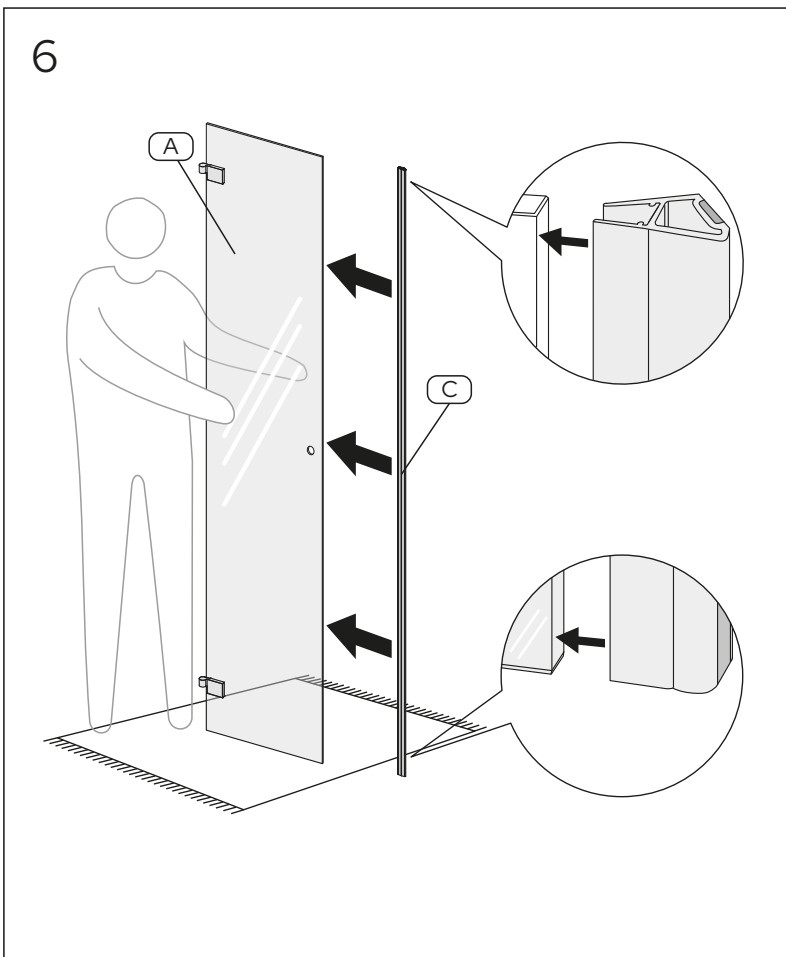

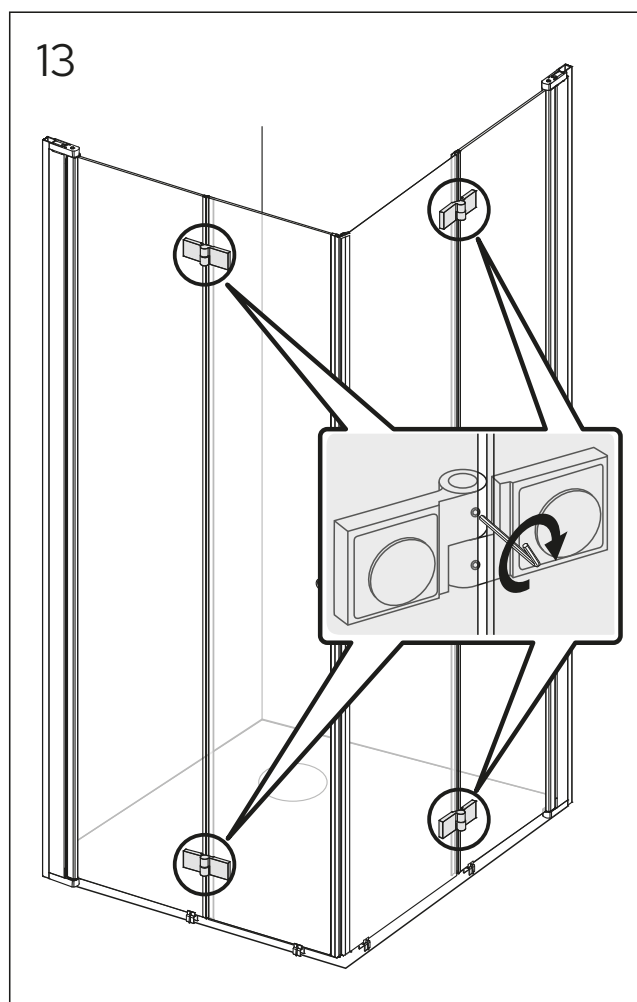
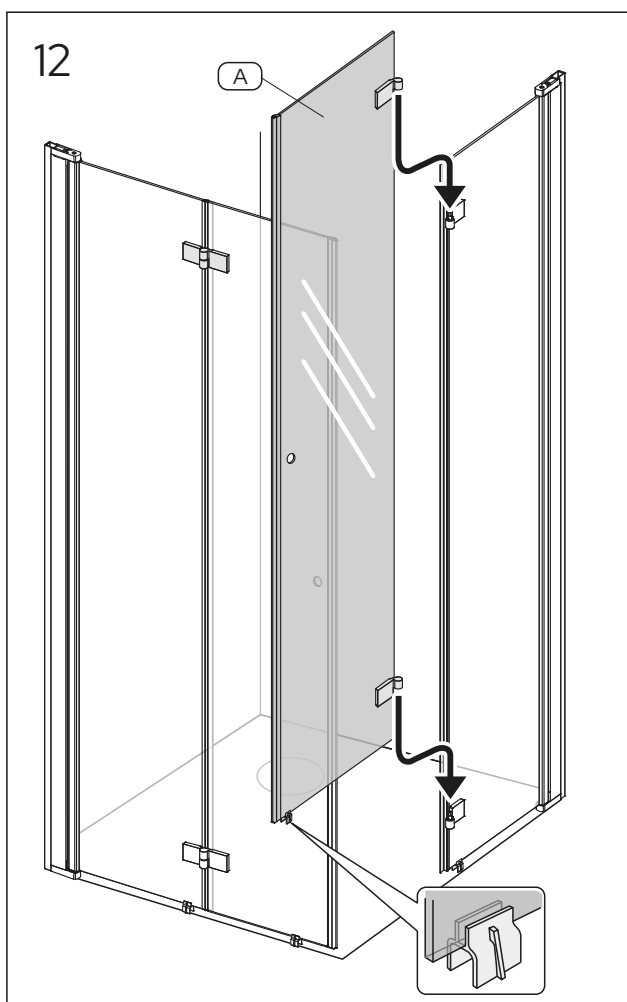
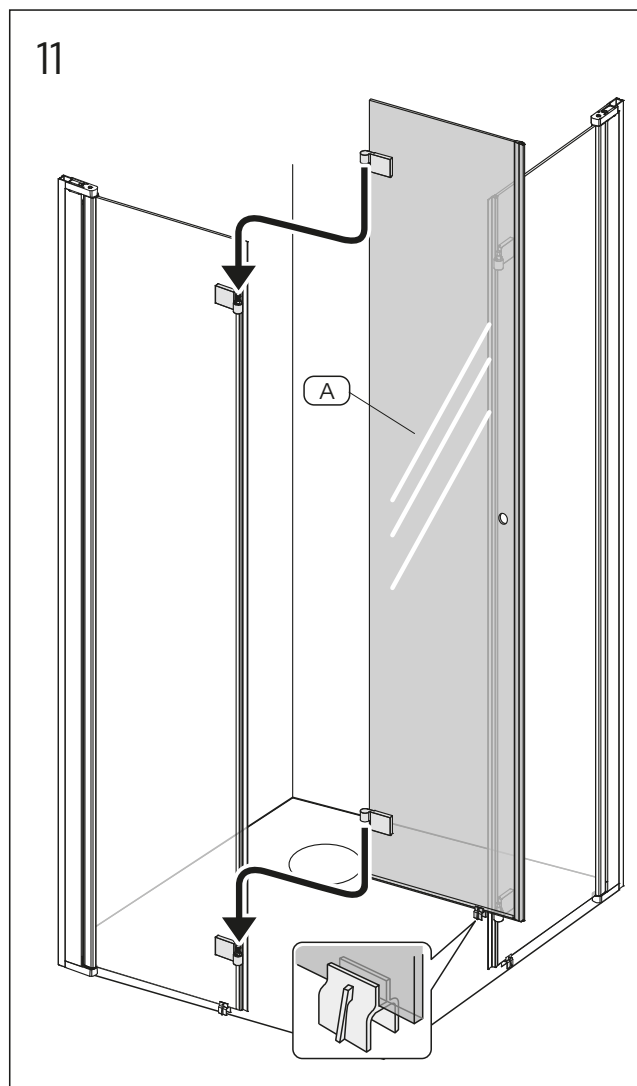
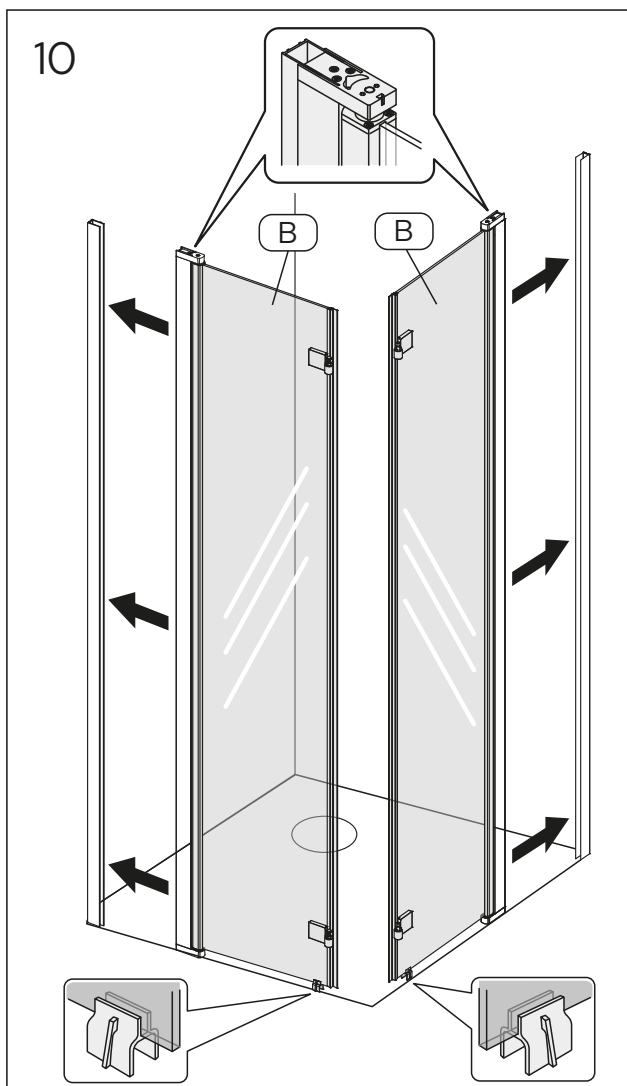

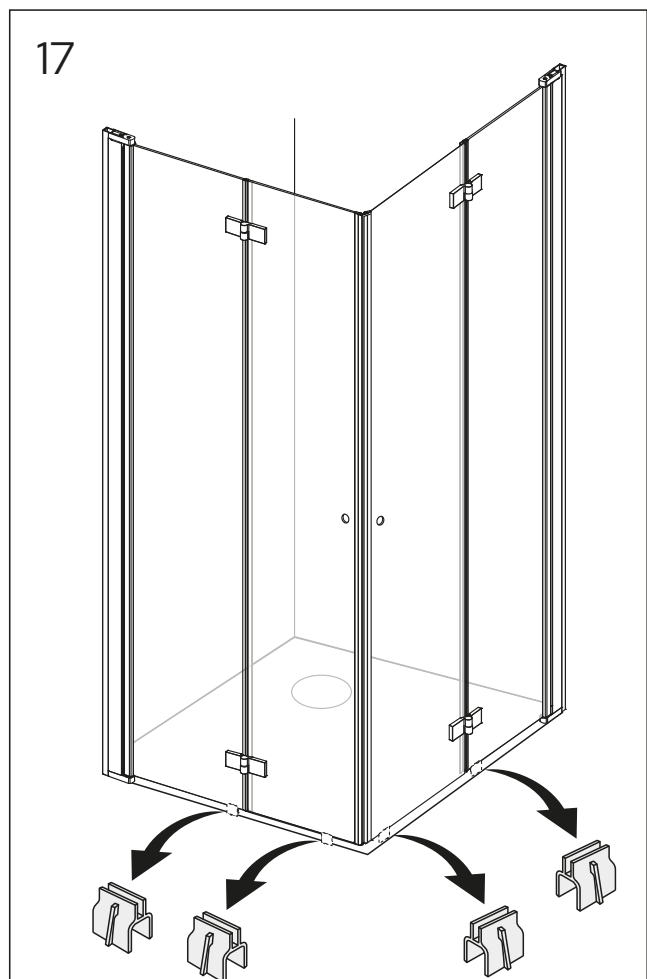
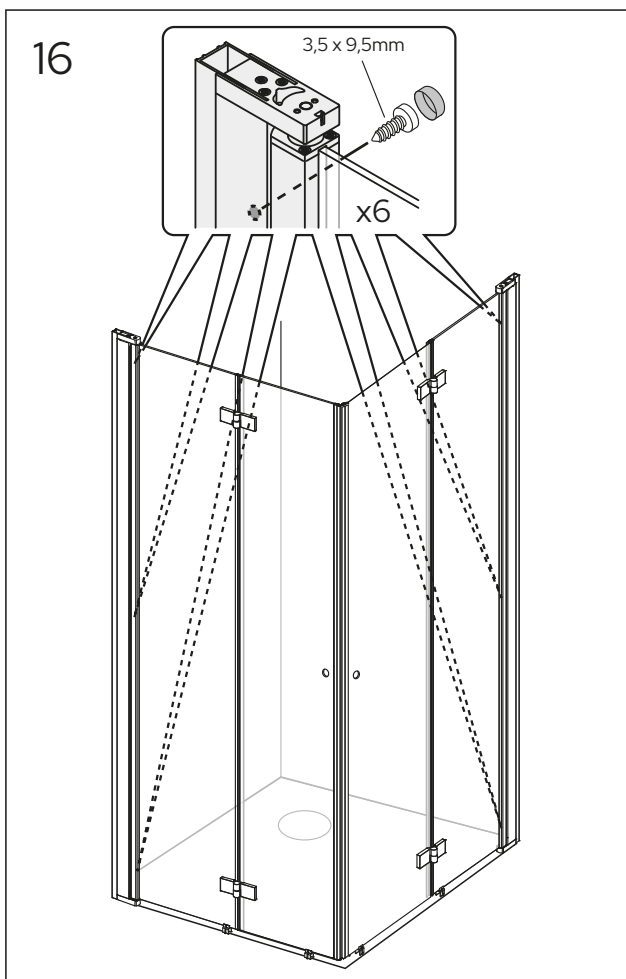
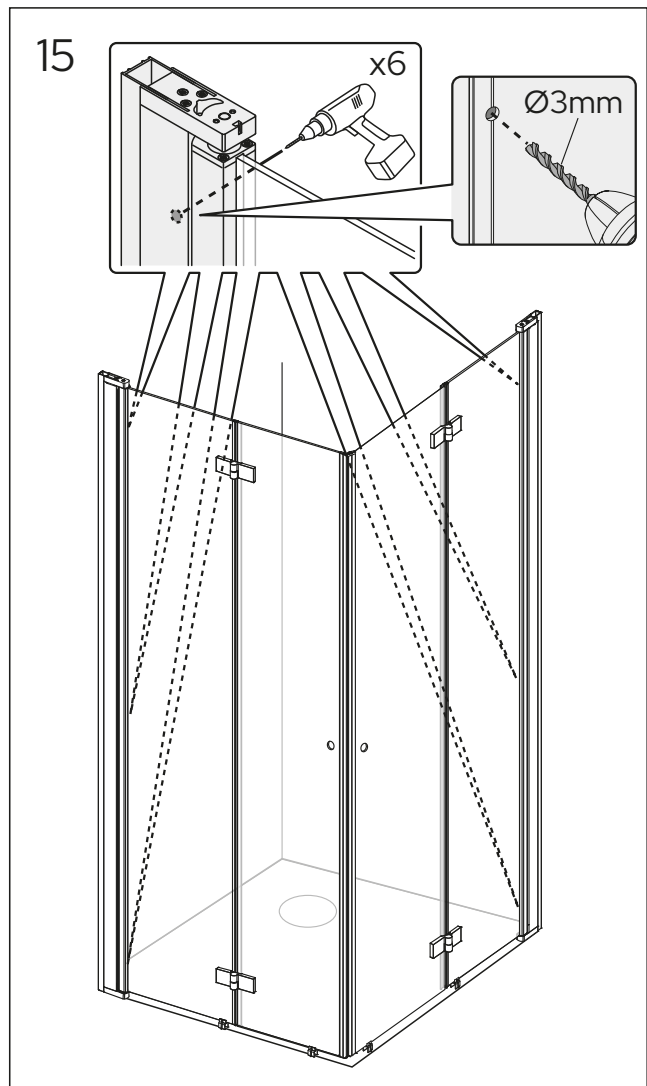
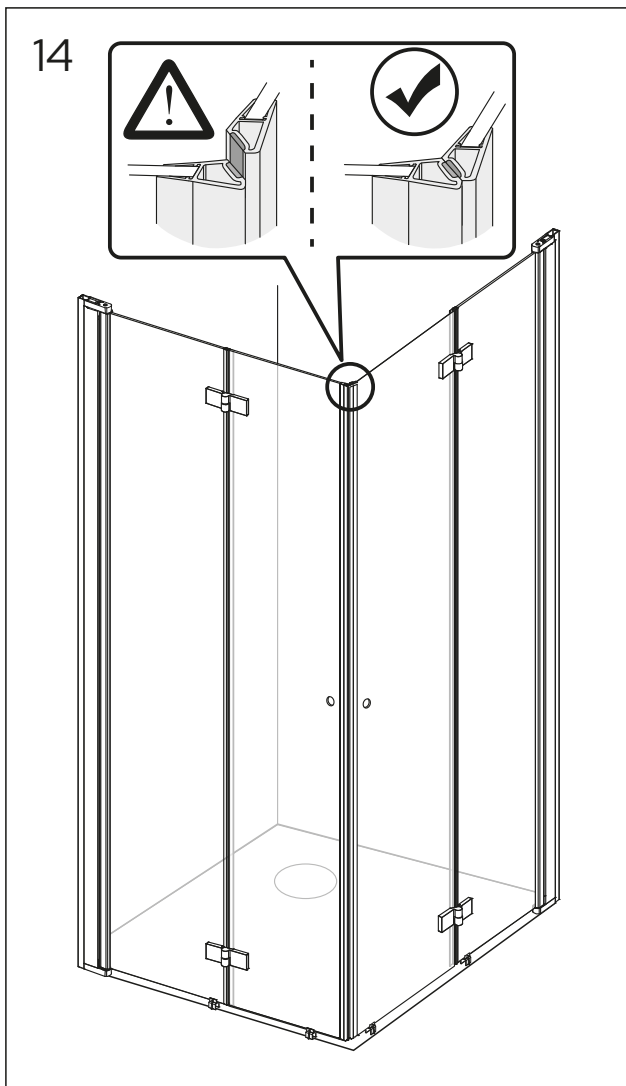

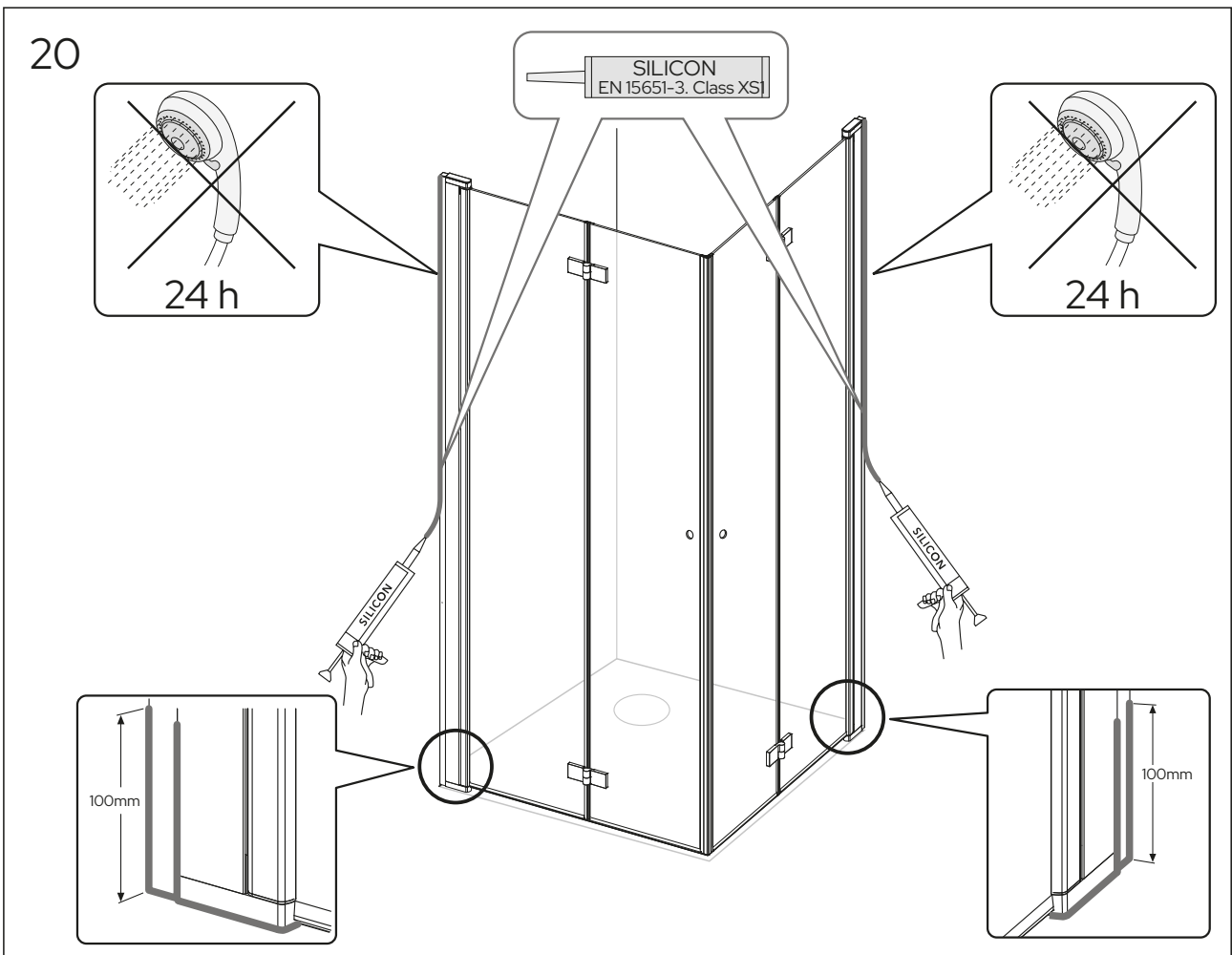
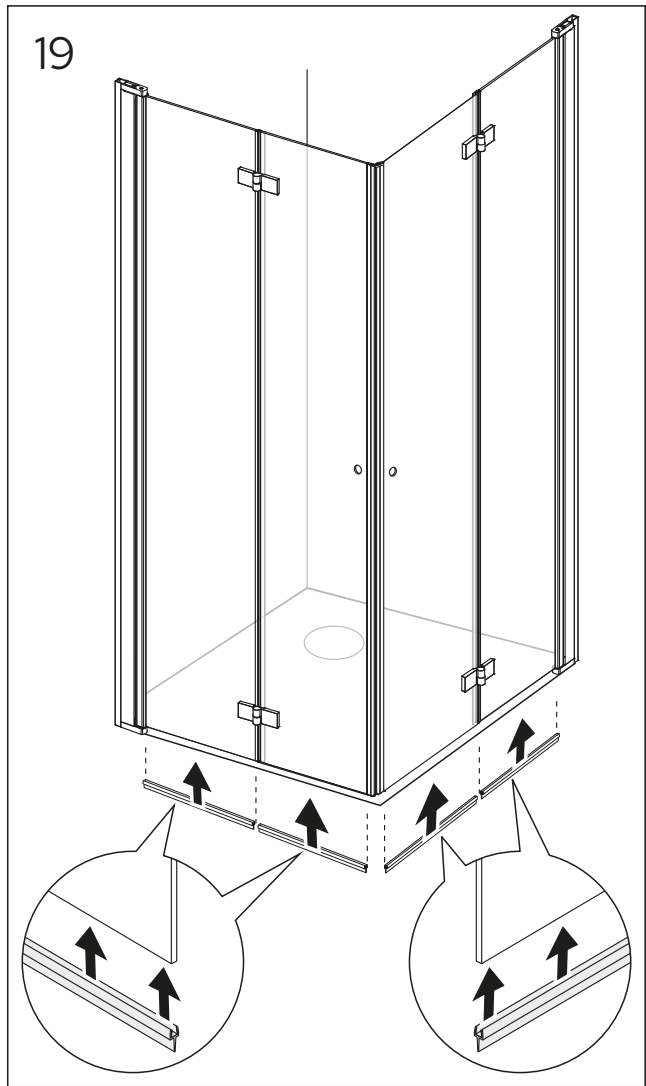
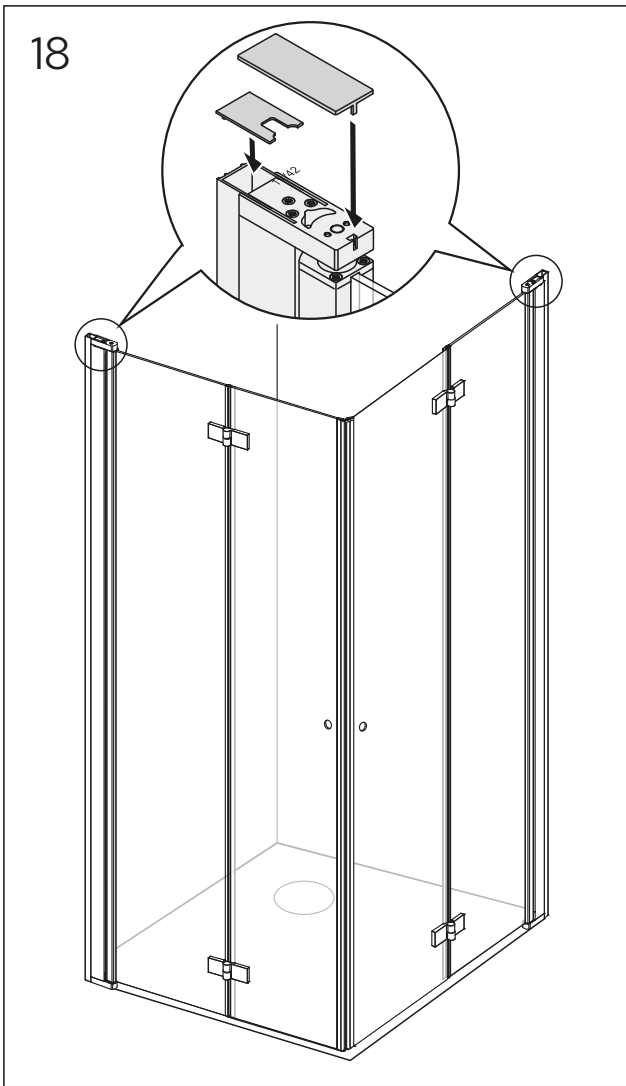



# NICHE

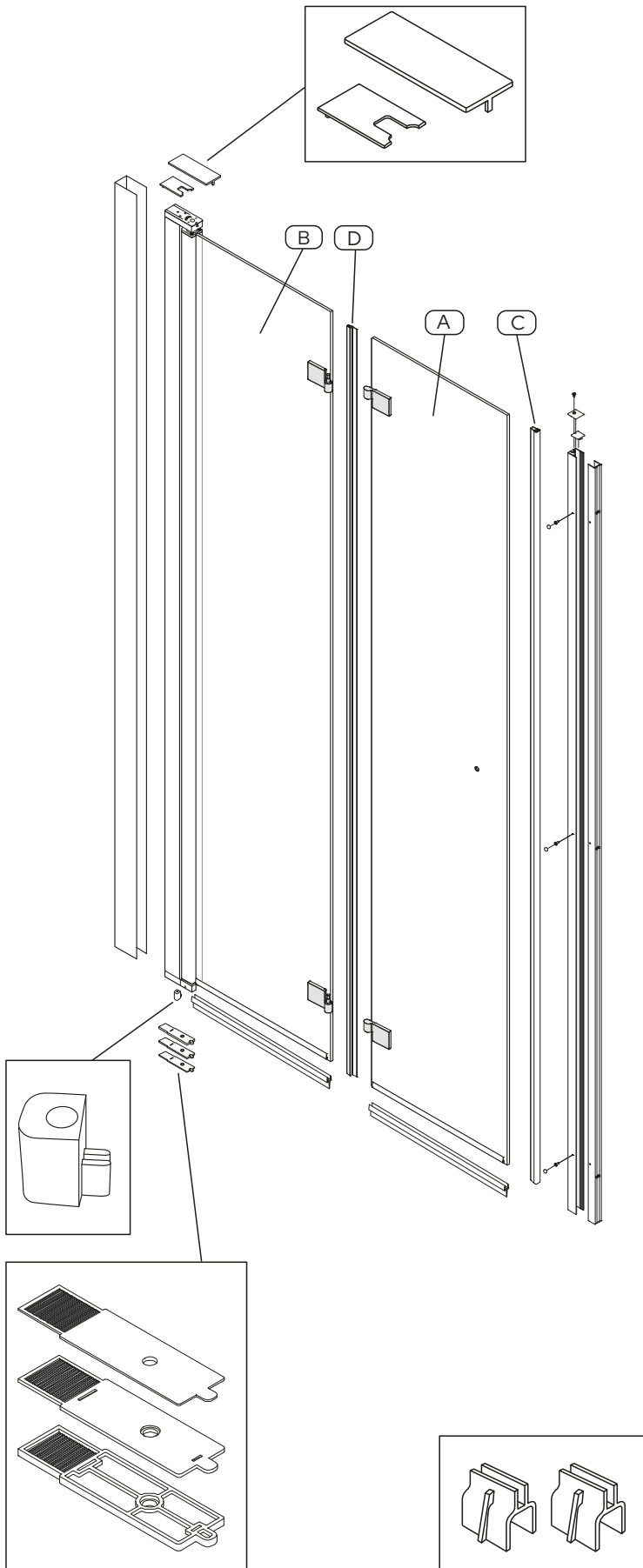
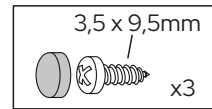
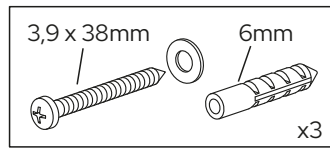
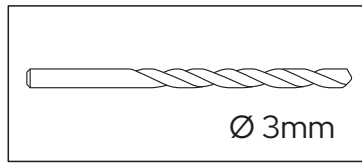



# NICHE

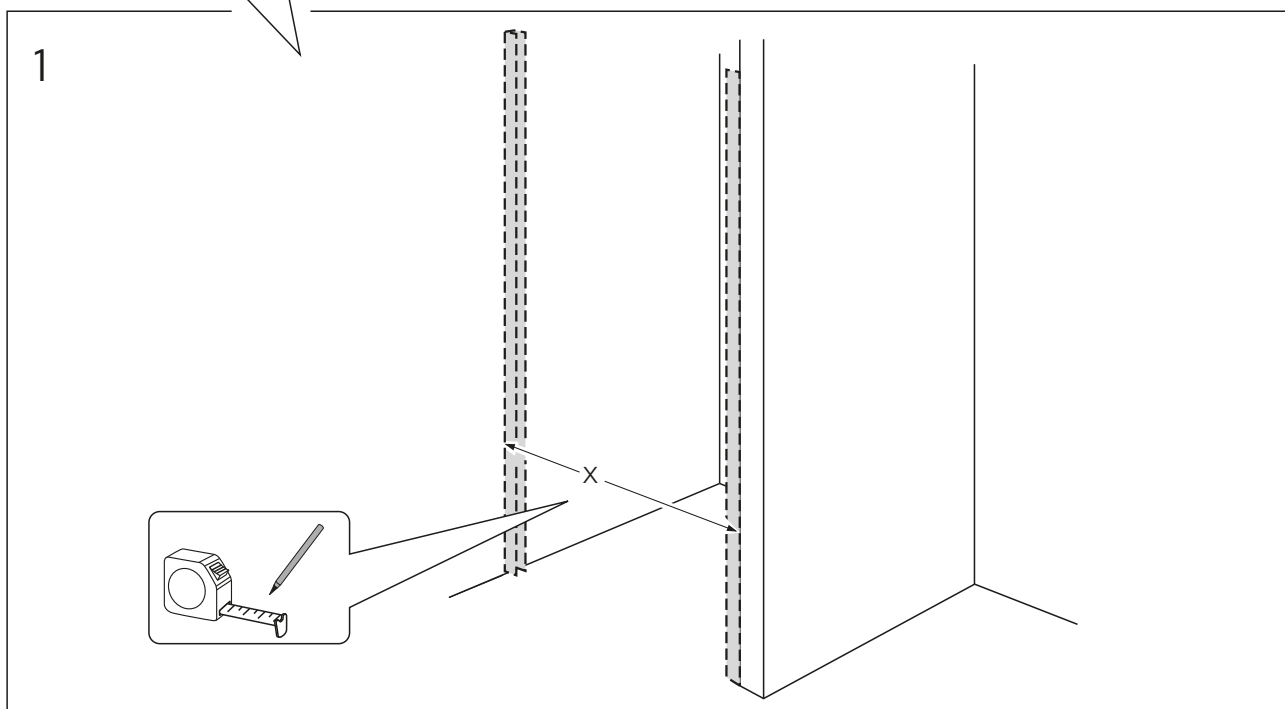
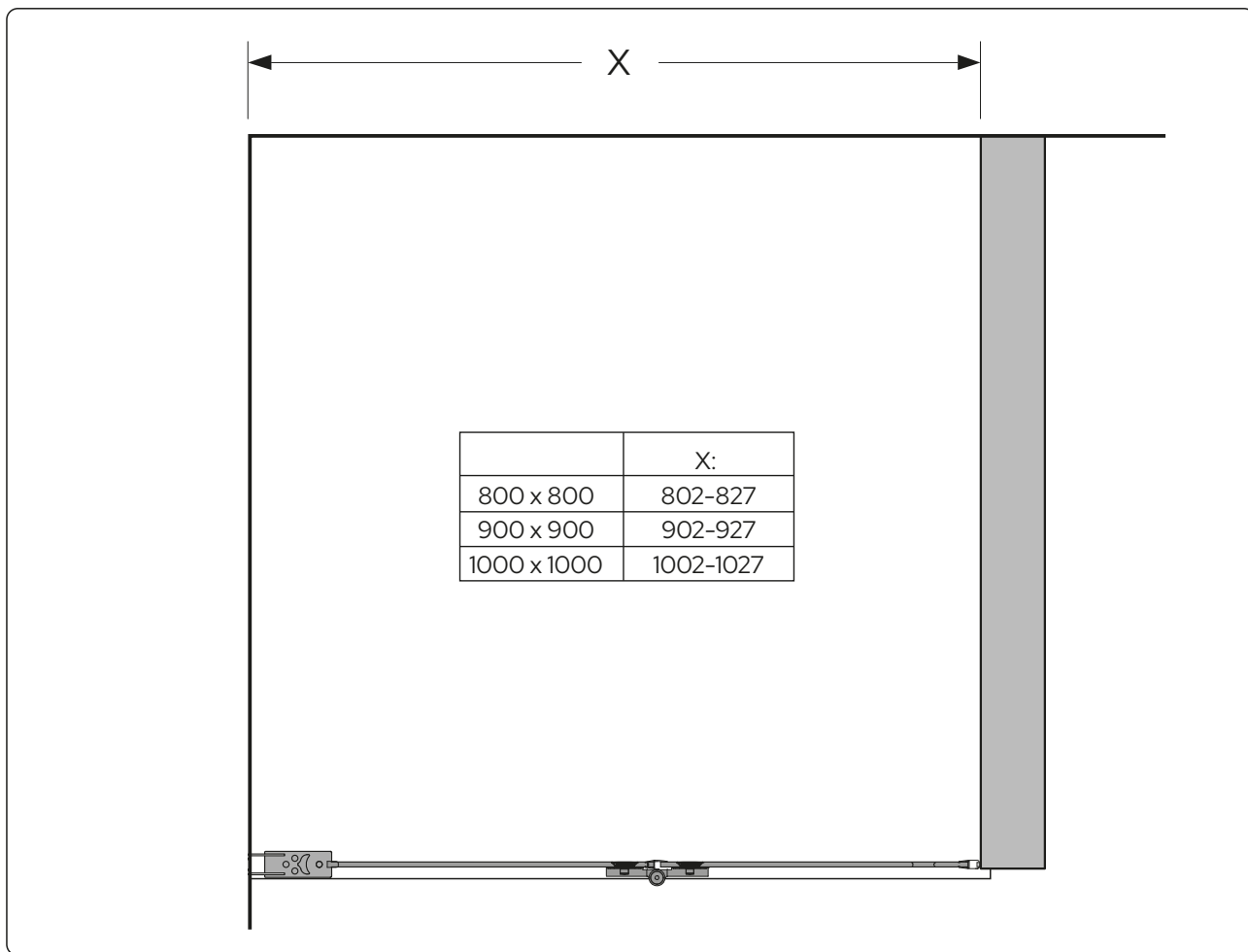

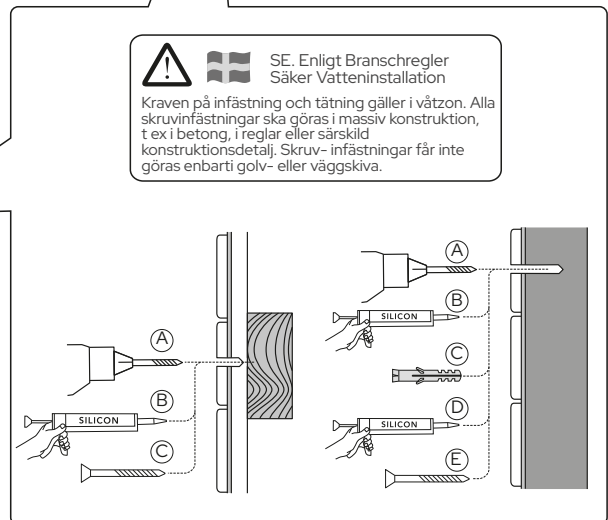
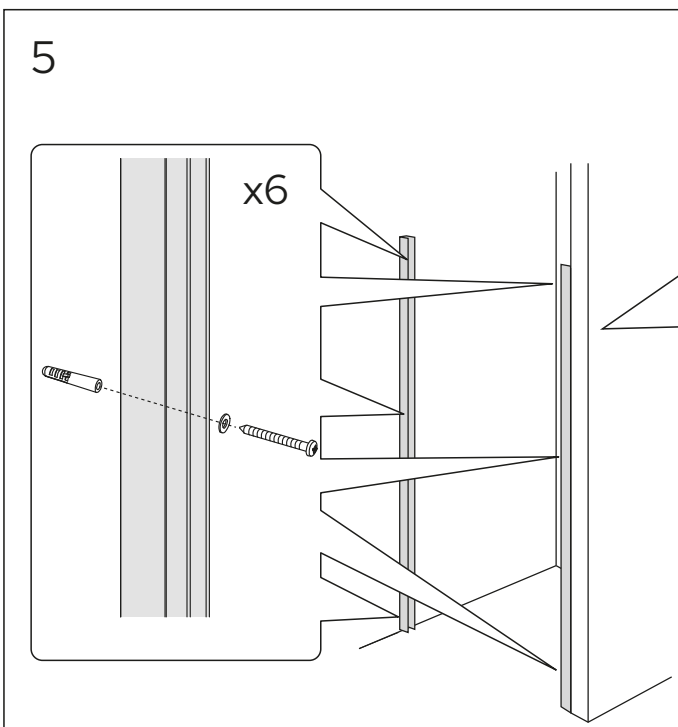
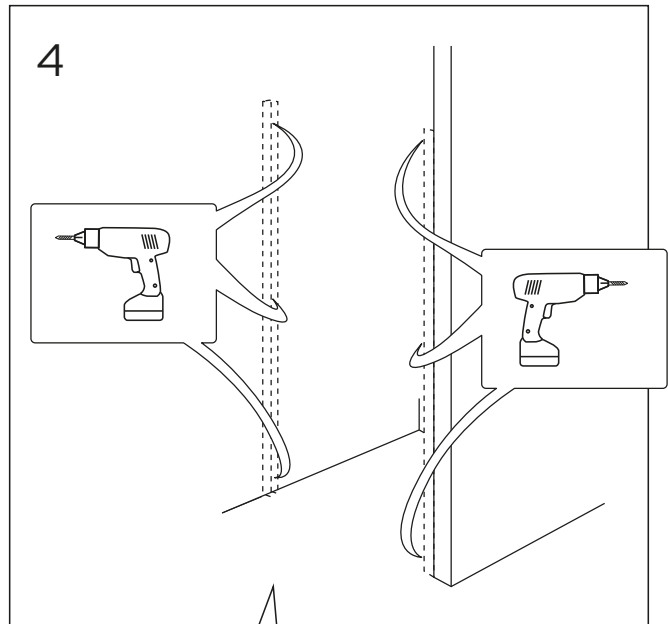
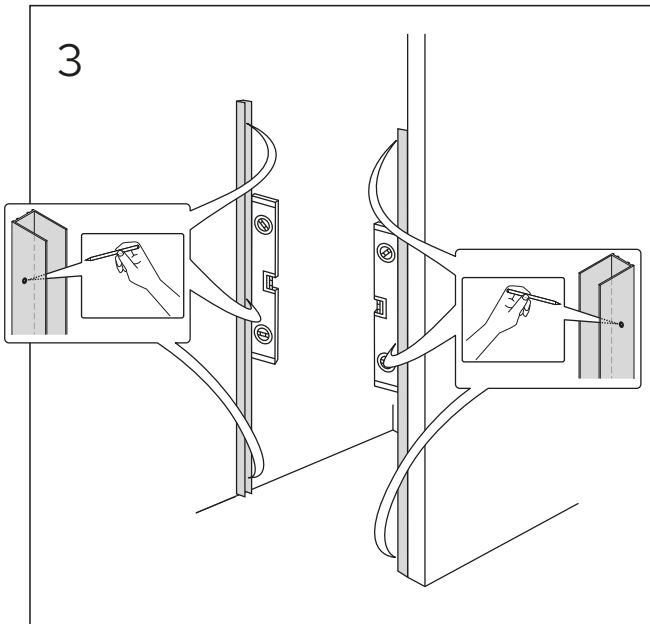
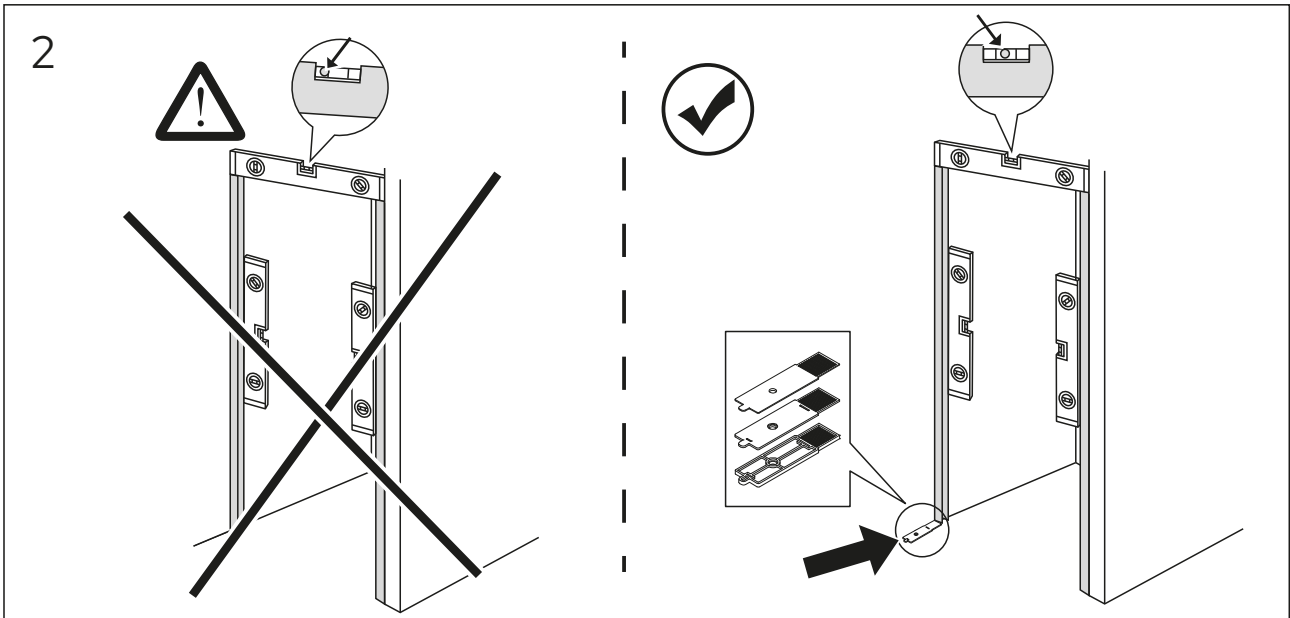

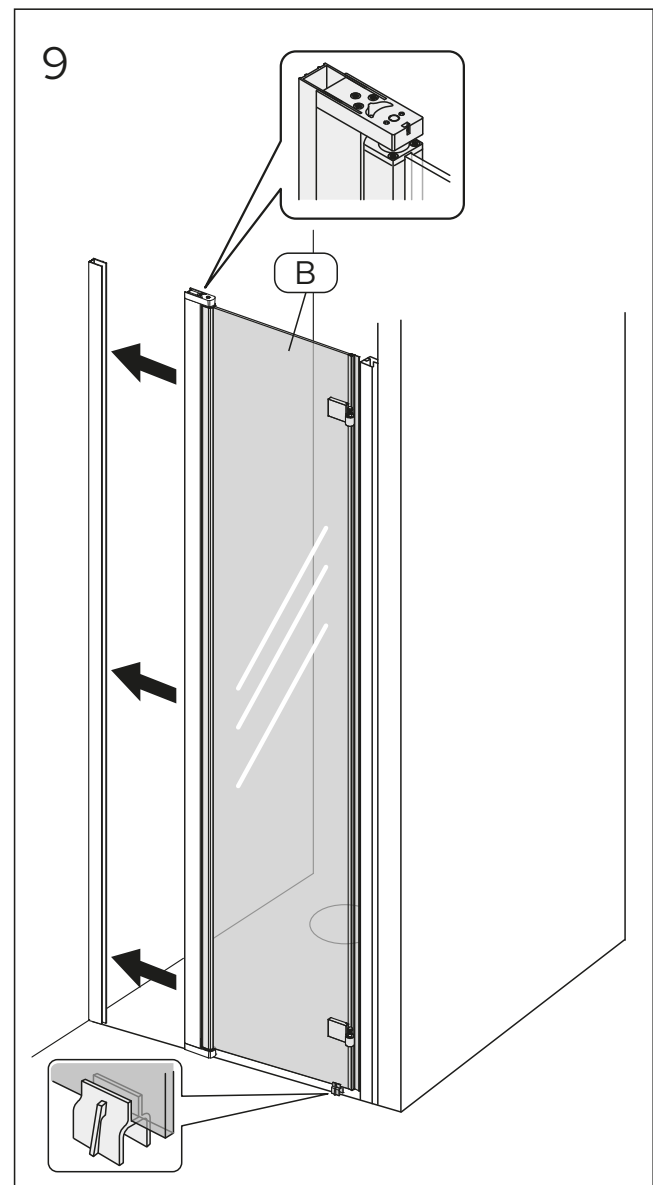
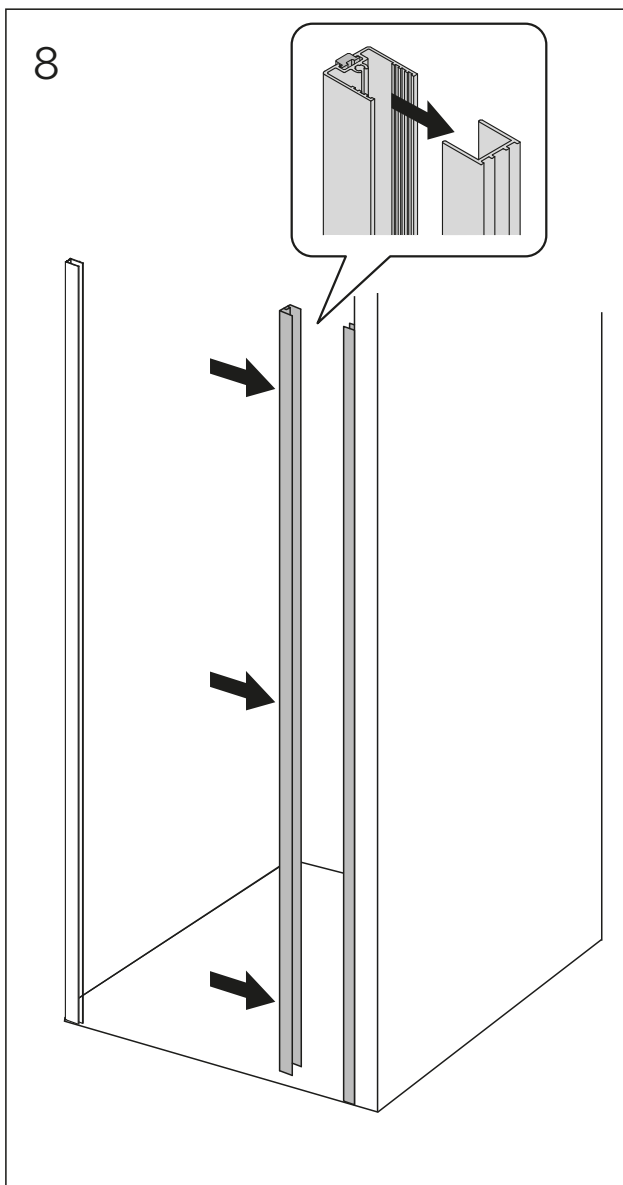
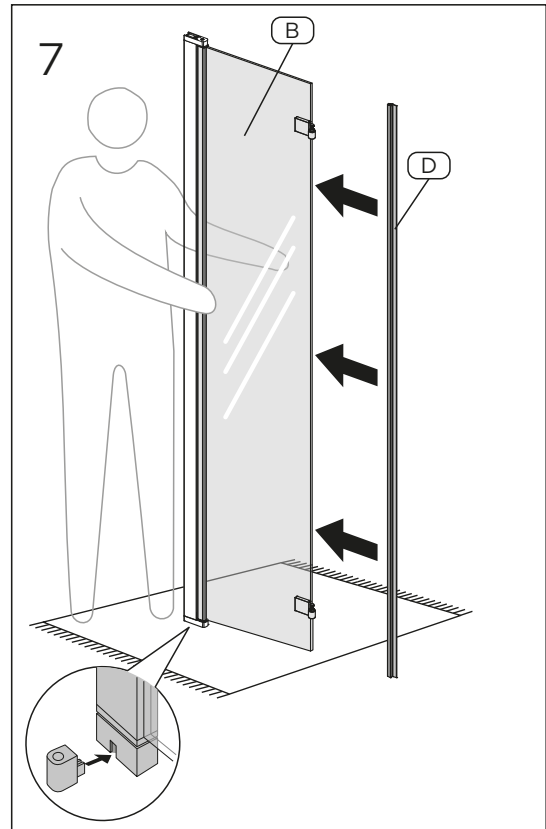
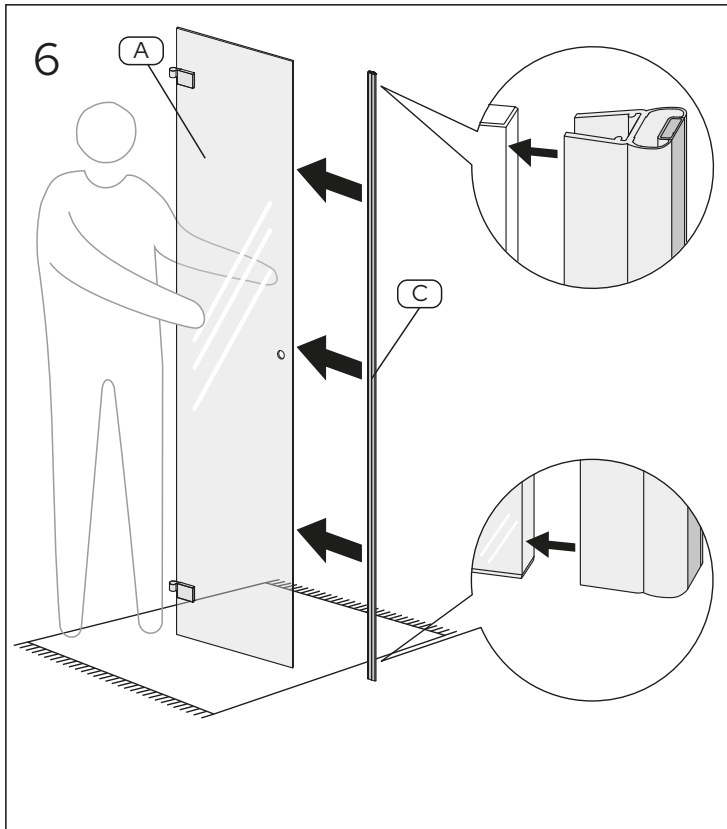

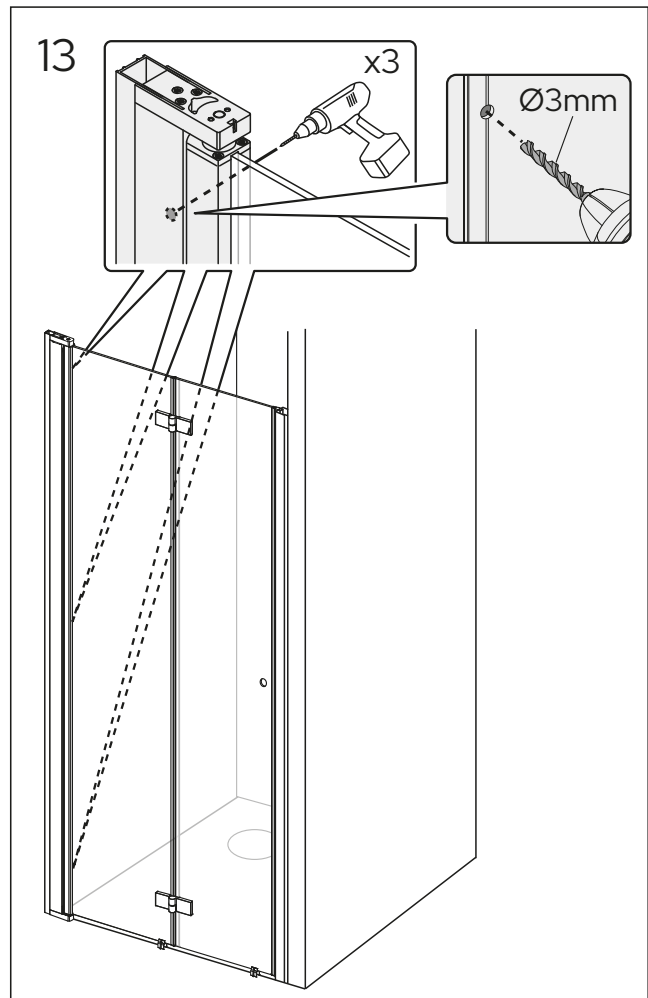
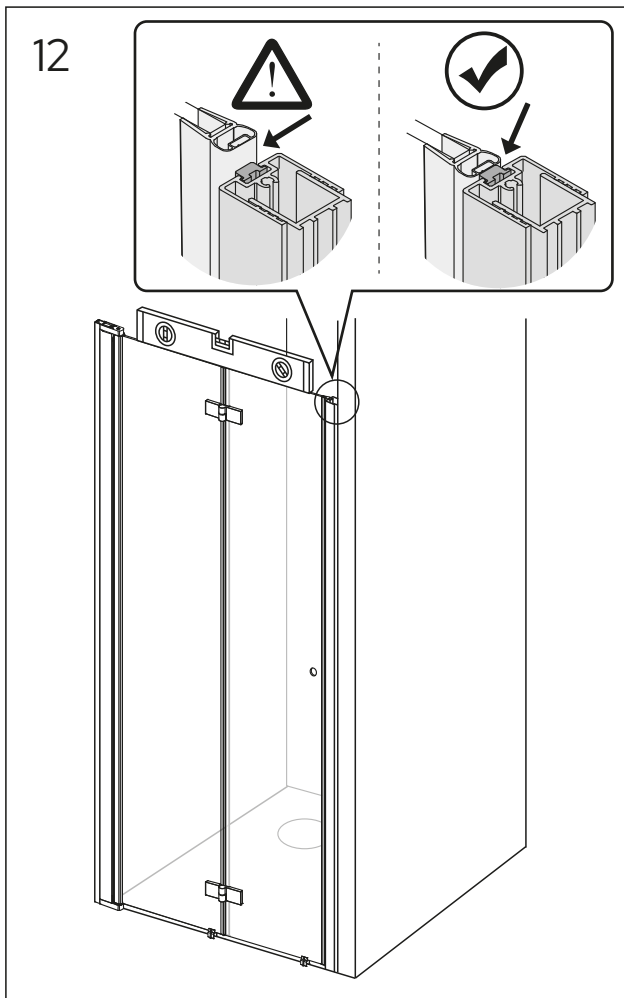
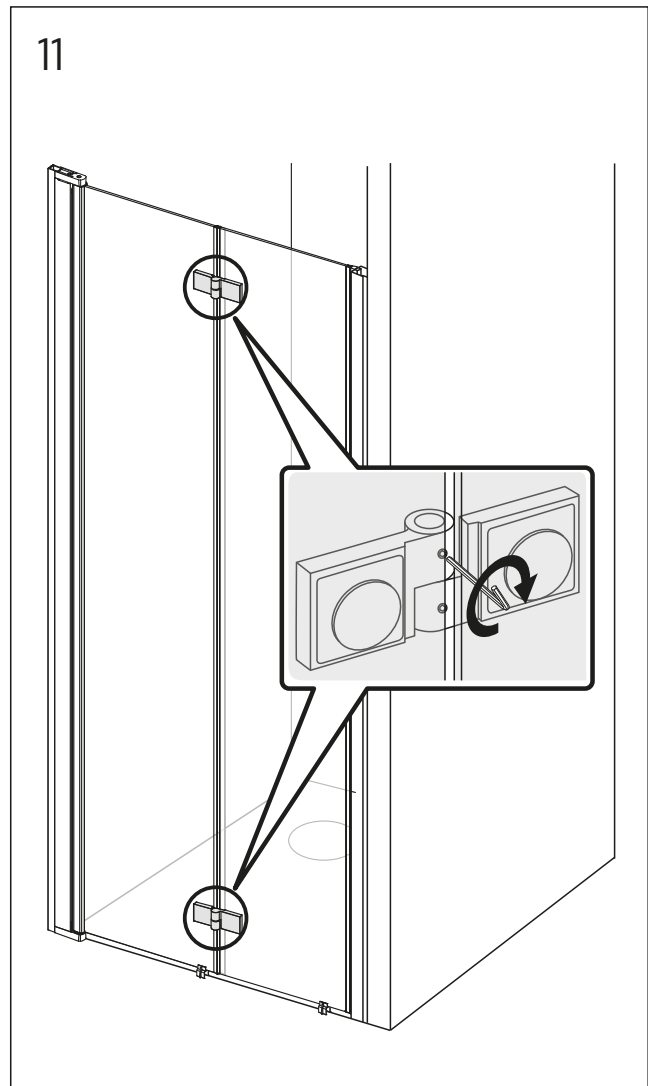
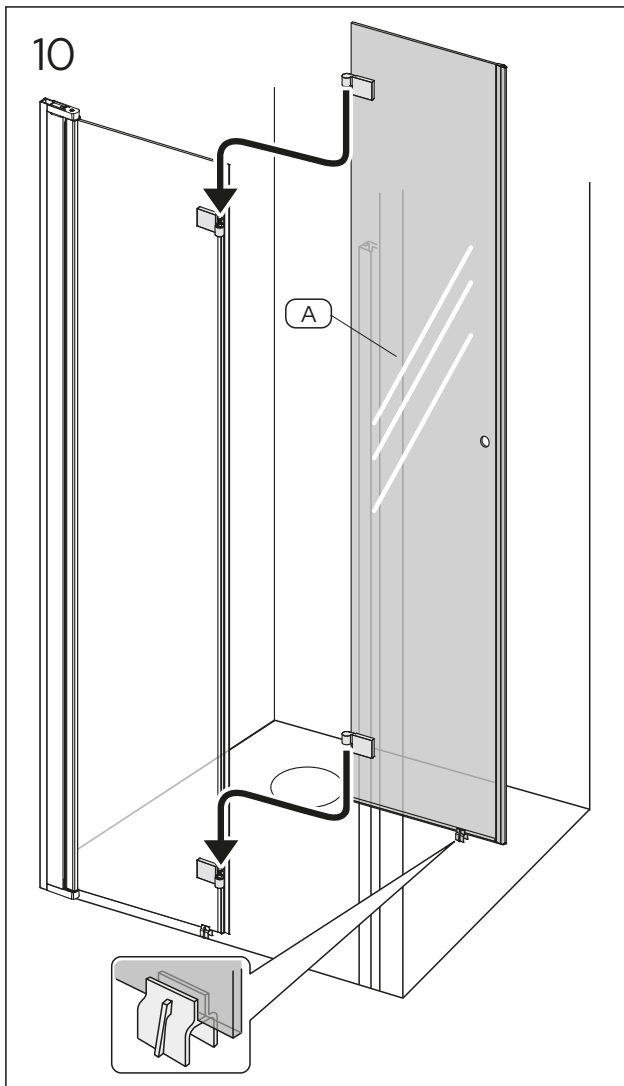

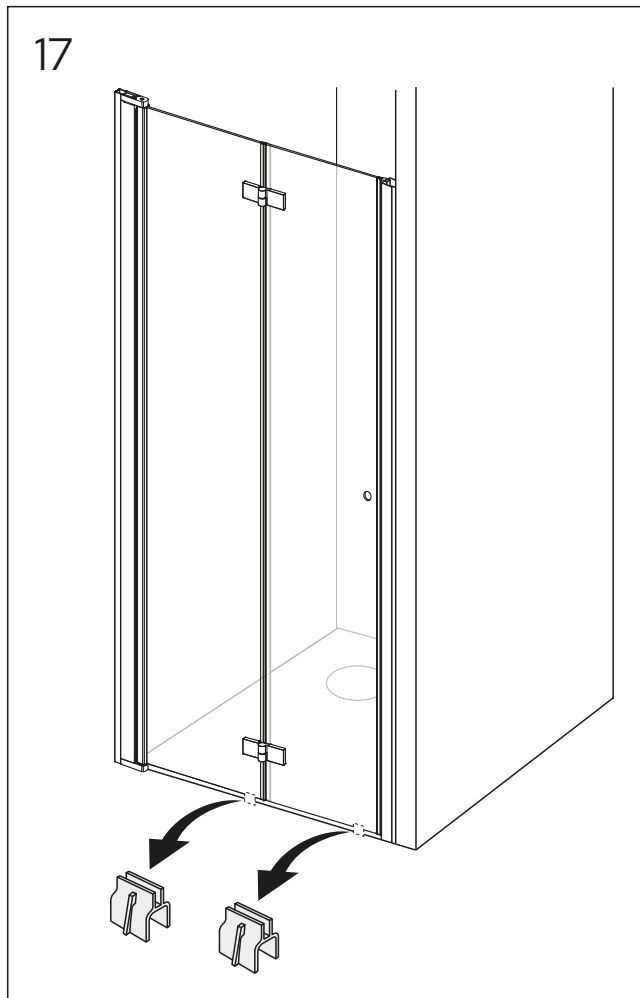
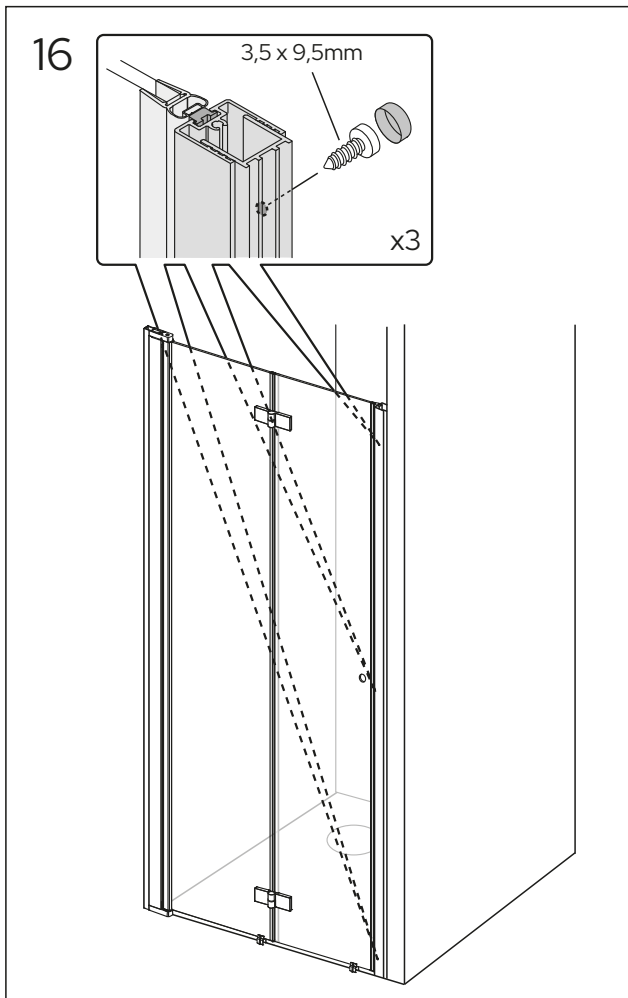
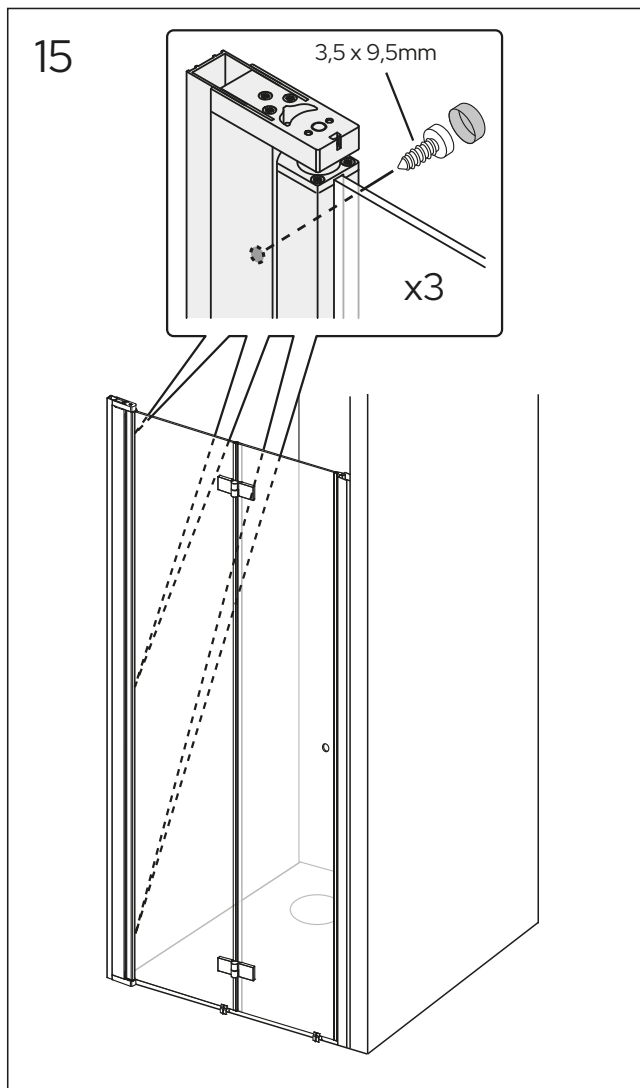
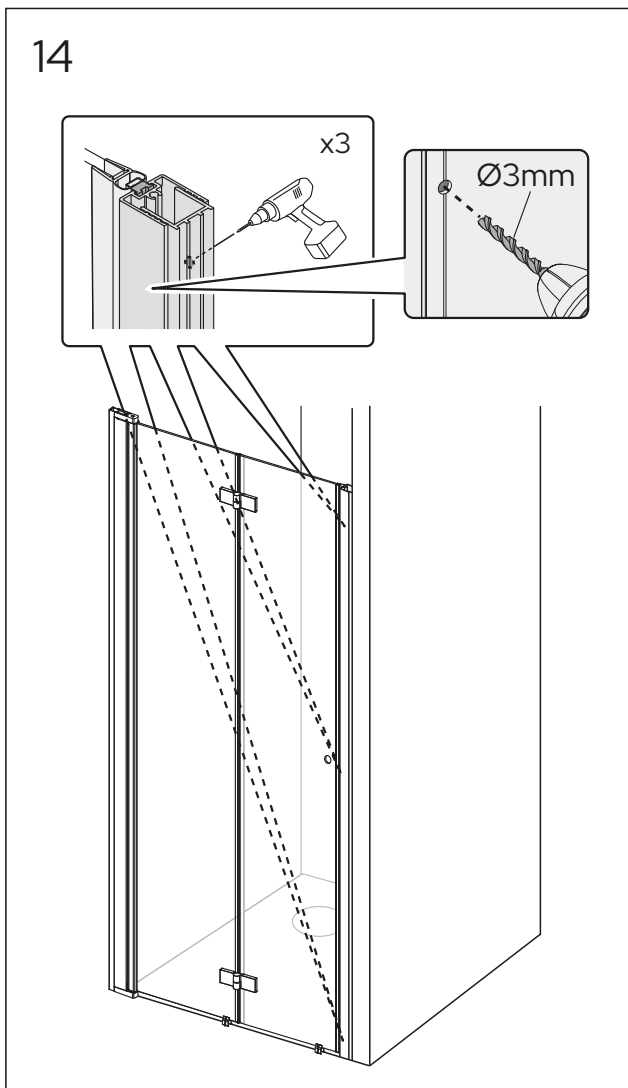

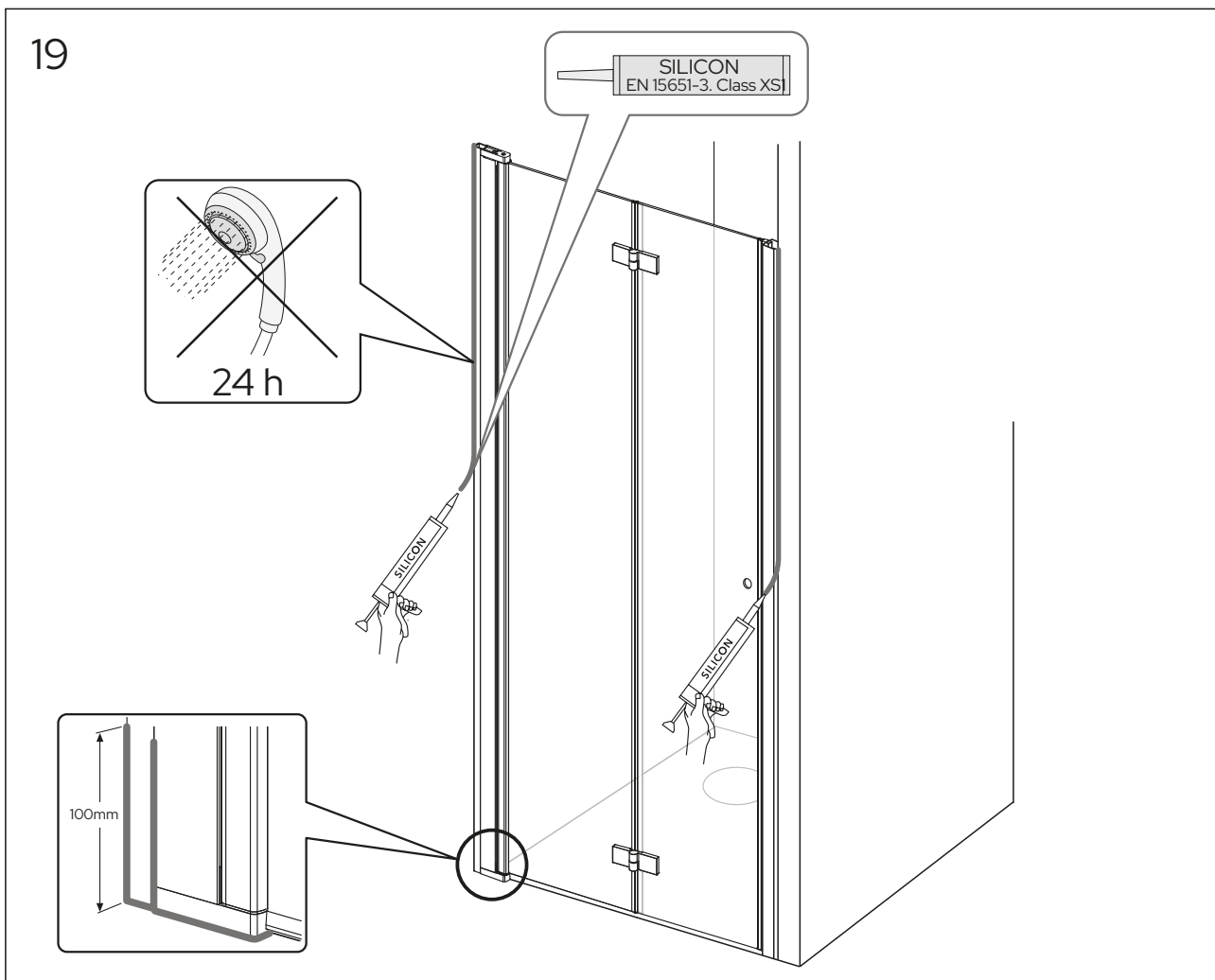
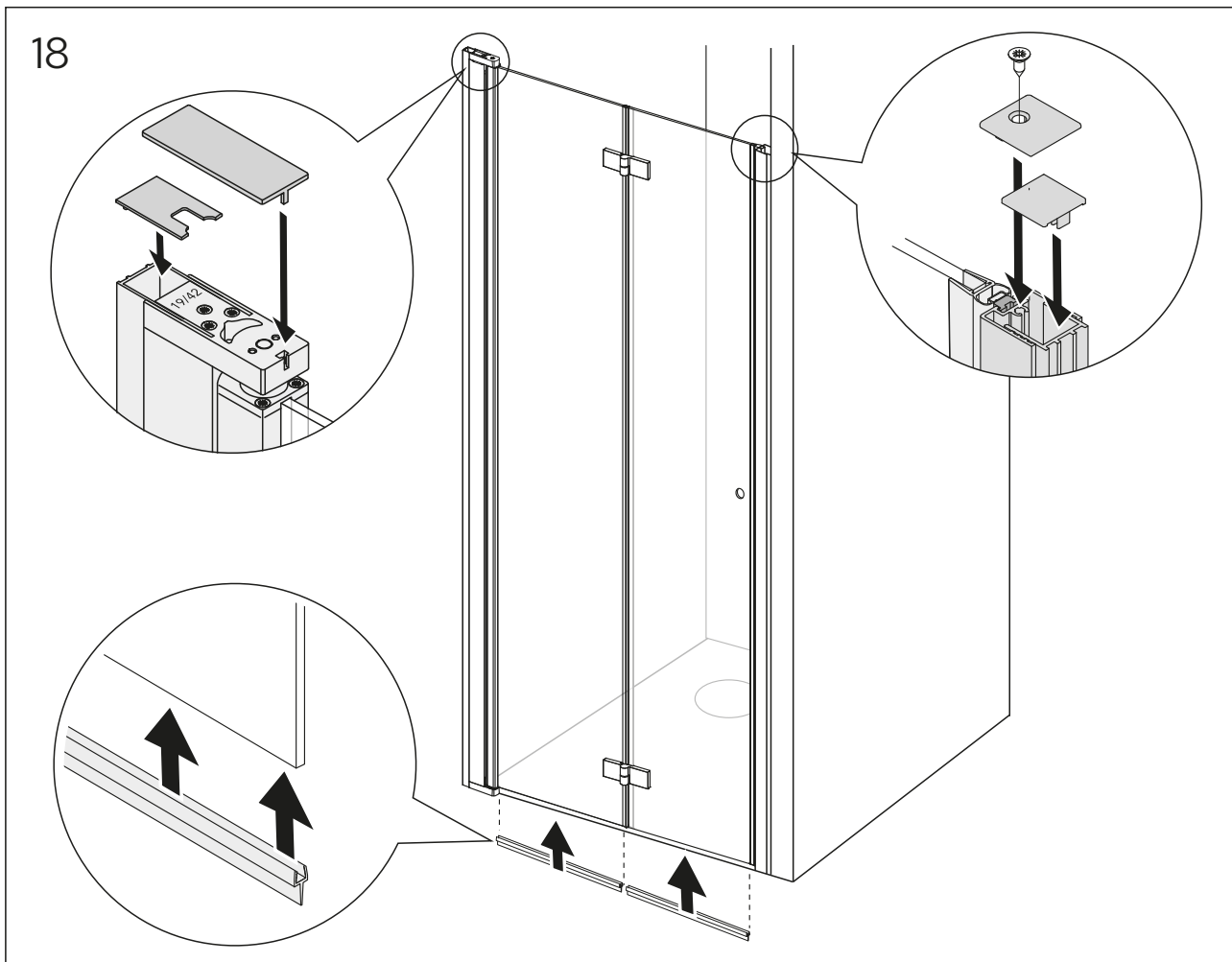

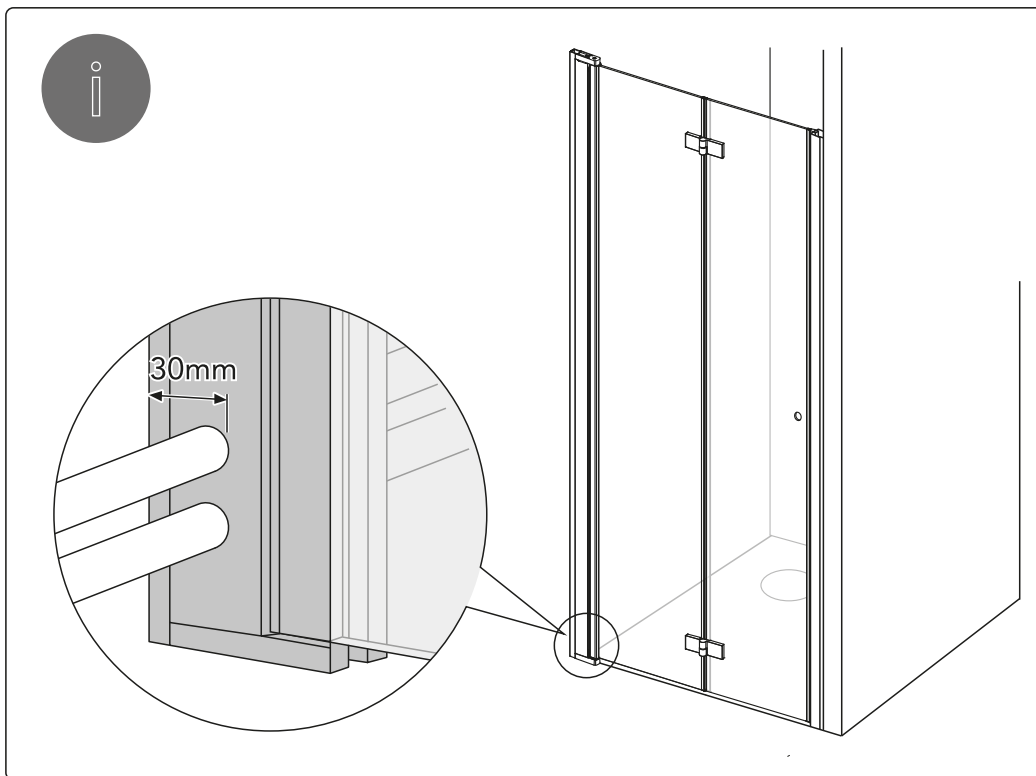

Reservdelar  
Reservedeler  
Reserve dele  
Varaosat  
Spare parts  
Varuosad  
Atsarginės dalys  
Rezerves daļas



Drift & skötsel  
Drift og vedligeholdelse  
Drift og vedlikehold  
Asennus-, käyttö- ja hoito-ohjeet  
Assembly and maintenance  
Paigaldamine & hooldamine  
Montaza un kopsana  
Montavimas ir priežiūra

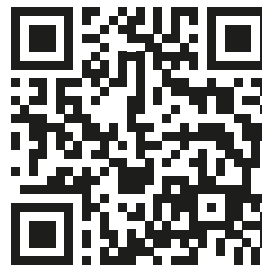

Sweden  
Gustavsberg AB  
Odelbergs väg 11  
134 46 Gustavsberg

Norway  
Gustavsberg AS  
Smeltedigelen 1  
0195 Oslo

Denmark  
Gustavsberg A/S  
Hobrovej 2  
2610 Rødovre

Finland  
Gustavsberg Oy  
Linnoitustie 6d  
02600 Espoo

Estonia  
Gustavsberg OY Esti Filialal  
F.R. Faehlmanni 6  
10125 Tallinn

Latvia  
Gustavsberg OY Latvijas Filiāle  
Roberta Hirsā iela 1, office 303  
LV-1045 Rīga

Lituania  
Gustavsberg OY filialas  
Polocko 28B-1  
Vilnius, LT 01205

