

# AXOR

DE / Gebrauchsanleitung / Montageanleitung	02
FR / Mode d'emploi / Instructions de montage	02
EN / Instructions for use / assembly instructions	03
IT / Istruzioni per l'uso / Istruzioni per Installazione	03
ES / Modo de empleo / Instrucciones de montaje	04
NL / Gebruiksaanwijzing / Handleiding	04
DK / Brugsanvisning / Monteringsvejledning	05
PT / Instruções para uso / Manual de Instalação	05
PL / Instrukcja obsługi / Instrukcja montażu	06
CS / Návod k použití / Montážní návod	06
SK / Návod na použitie / Montážny návod	07
ZH / 用户手册 / 组装说明	07
RU / Руководство пользователя / Инструкция по монтажу	08
FI / Käyttöohje / Asennusohje	08
SV / Bruksanvisning / Monteringsanvisning	09
LT / Vartotojo instrukcija / Montavimo instrukcijos	09
HR / Upute za uporabu / Uputstva za instalaciju	10
TR / Kullanım kılavuzu / Montaj kılavuzu	10
RO / Manual de utilizare / Instrucțiuni de montare	11
EL / Οδηγίες χρήσης / Οδηγία συναρμολόγησης	11
SL / Navodilo za uporabo / Navodila za montažo	12
ET / Kasutusjuhend / Paigaldusjuhend	12
LV / Lietošanas pamācība / Montāžas instrukcija	13
SR / Uputstvo za upotrebu / Uputstvo za montažu	13
NO / Bruksanvisning / Montasjeveiledning	14
BG / Инструкция за употреба / Ръководство за монтаж	14
SQ / Udhëzuesi i përdorimit / Udhëzime rreth montimit	15
AR / دليل الاستخدام / تعليمات التجميع	15
HU / Használati útmutató / Szerelési útmutató	16
JP / 取扱説明書 / 施工説明書	16

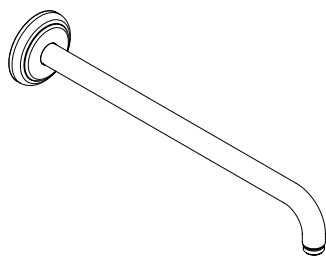

AXOR Montreux 389  
27348XXX

INSTALLATION

### △ SICHERHEITSHINWEISE

- △ Bei der Montage müssen zur Vermeidung von Quetsch- und Schnittverletzungen Handschuhe getragen werden.
- △ Der Kopfbrausearm ist nur für das Halten der Kopfbrause ausgelegt, er darf nicht mit weiteren Gegenständen belastet werden!

### MONTAGEHINWEISE

- / Vor der Montage muss das Produkt auf Transportschäden untersucht werden. Nach dem Einbau werden keine Transport- oder Oberflächenschäden anerkannt.
- / Die Leitungen und die Armatur müssen nach den gültigen Normen montiert, gespült und geprüft werden.
- / Die in den Ländern jeweils gültigen Installationsrichtlinien sind einzuhalten.
- / Bei der Montage des Produktes durch qualifiziertes Fachpersonal ist darauf zu achten, dass die Befestigungsfläche im gesamten Bereich der Befestigung plan ist (keine vorstehenden Fugen oder Fliesenversatz), der Wandaufbau für eine Montage des Produktes geeignet ist und keine Schwachstellen aufweist.

### SYMBOLERKLÄRUNG

 Kein essigsäurehaltiges Silikon verwenden!

 MASSE (siehe Seite 17)

 SERVICE TEILE (siehe Seite 20)

XXX = Farbcodierung  
 000 = Chrom  
 020 = Polished Chrome  
 130 = Polished Bronze  
 140 = Brushed Bronze  
 250 = Brushed Gold-Optic  
 260 = Brushed Chrome  
 300 = Polished Redgold  
 310 = Brushed Redgold  
 330 = Polished Black Chrome  
 340 = Brushed Black Chrome  
 800 = Stainless Steel Optic  
 820 = Brushed Nickel  
 830 = Polished Nickel  
 930 = Polished Brass  
 950 = Brushed Brass  
 990 = Polished Gold-Optic

### MONTAGE

(siehe Seite 18)



### △ CONSIGNES DE SÉCURITÉ

- △ Lors du montage, porter des gants de protection pour éviter toute blessure par écrasement ou coupure.
- △ Le bras de la douchette n'est conçu que pour tenir la douchette et ne doit pas servir à la suspension d'autres objets !

### INSTRUCTIONS POUR LE MONTAGE

- / Avant son montage, s'assurer que le produit n'a subi aucun dommage pendant le transport. Après le montage, tout dommage de transport ou de surface ne pourra pas être reconnu.
- / Les conduites et la robinetterie doivent être montés, rincés et contrôlés selon les normes en vigueur.
- / Les directives d'installation en vigueur dans le pays concerné doivent être respectées.
- / Lors du montage de ce produit par du personnel qualifié, veiller à ce que la surface de fixation soit bien plane dans toute la zone de fixation (pas de dépassement de joints ou de déport de carreaux), à ce que le mur se prête au montage du produit et ne présente aucun point fragile.

### DESCRIPTION DU SYMBOLE

 Ne pas utiliser de silicone contenant de l'acide acétique!

 DIMENSIONS (voir pages 17)

 PIÈCES DÉTACHÉES (voir pages 20)

XXX = Couleurs  
 000 = Chromé  
 020 = Polished Chrome  
 130 = Polished Bronze  
 140 = Brushed Bronze  
 250 = Brushed Gold-Optic  
 260 = Brushed Chrome  
 300 = Polished Redgold  
 310 = Brushed Redgold  
 330 = Polished Black Chrome  
 340 = Brushed Black Chrome  
 800 = Stainless Steel Optic  
 820 = Brushed Nickel  
 830 = Polished Nickel  
 930 = Polished Brass  
 950 = Brushed Brass  
 990 = Polished Gold-Optic

### MONTAGE

(voir pages 18)



## △ SAFETY NOTES

- △ Gloves should be worn during installation to prevent crushing and cutting injuries.
- △ The arm of the shower head is intended only to hold the shower head. Do not load it down with other objects!

## INSTALLATION INSTRUCTIONS

- / Prior to installation, inspect the product for transport damages. After it has been installed, no transport or surface damage will be honoured.
- / The pipes and the fixture must be installed, flushed and tested as per the applicable standards.
- / The plumbing codes applicable in the respective countries must be observed.
- / During installation of the product by qualified trained personnel, make sure that the entire fastening surface is even and smooth (no protruding seams or tile offset), that the finish of the wall is suitable to apply the product and has no weak points.

## SYMBOL DESCRIPTION



Do not use silicone containing acetic acid!



DIMENSIONS (see page 17)



SPARE PARTS (see page 20)

XXX = Colors  
 000 = Chrome Plated  
 020 = Polished Chrome  
 130 = Polished Bronze  
 140 = Brushed Bronze  
 250 = Brushed Gold-Optic  
 260 = Brushed Chrome  
 300 = Polished Redgold  
 310 = Brushed Redgold  
 330 = Polished Black Chrome  
 340 = Brushed Black Chrome  
 800 = Stainless Steel Optic  
 820 = Brushed Nickel  
 830 = Polished Nickel  
 930 = Polished Brass  
 950 = Brushed Brass  
 990 = Polished Gold-Optic

## △ INDICAZIONI SULLA SICUREZZA

- △ Durante il montaggio, per evitare ferite da schiacciamento e da taglio bisogna indossare guanti protettivi.
- △ Il braccio del soffione della doccia è progettato per sostenere solo quest'ultimo, non va sovraccaricato con altri oggetti!

## ISTRUZIONI PER IL MONTAGGIO

- / Prima del montaggio è necessario controllare che non ci siano stati danni durante il trasporto. Una volta eseguito il montaggio, non verranno riconosciuti eventuali danni di trasporto o delle superfici.
- / Montare, lavare e controllare tubature e rubinetteria rispettando le norme correnti.
- / Vanno rispettate le direttive di installazione nazionali vigenti nel rispettivo paese.
- / Per il montaggio del prodotto da personale specializzato qualificato bisogna fare attenzione, che la superficie di fissaggio, in tutto il campo di fissaggio, sia piana (nessuna giunzione sporgente o sfalsamento di piastrella), la costruzione della parete sia adatta al montaggio del prodotto e che non presenti alcun punto debole.

## DESCRIZIONE SIMBOLO



Non utilizzare silicone contenente acido acetico!



INGOMBRI (vedi pagg. 17)



PARTI DI RICAMBIO

(vedi pagg. 20)  
 XXX = Trattamento  
 000 = Cromato  
 020 = Polished Chrome  
 130 = Polished Bronze  
 140 = Brushed Bronze  
 250 = Brushed Gold-Optic  
 260 = Brushed Chrome  
 300 = Polished Redgold  
 310 = Brushed Redgold  
 330 = Polished Black Chrome  
 340 = Brushed Black Chrome  
 800 = Stainless Steel Optic  
 820 = Brushed Nickel  
 830 = Polished Nickel  
 930 = Polished Brass  
 950 = Brushed Brass  
 990 = Polished Gold-Optic

## ASSEMBLY

(see page 18)



## MONTAGGIO

(vedi pagg. 18)



## △ INDICACIONES DE SEGURIDAD

- △ Durante el montaje deben utilizarse guantes para evitar heridas por aplastamiento o corte.
- △ El brazo del pulverizador de ducha solo está previsto para soportar el pulverizador de ducha y no debe cargarse con otros objetos!

## INDICACIONES PARA EL MONTAJE

- / Antes del montaje se debe examinar el producto contra daños de transporte. Después de la instalación no se reconoce ningún daño de transporte o de superficie.
- / Los conductos y la grifería deben montarse, lavarse y comprobarse según las normas vigentes.
- / Es obligatorio el cumplimiento de las directrices de instalación vigentes en el país respectivo.
- / Durante el montaje del producto, mediante personal especializado, se debe asegurar de que la superficie de sujeción en todo el área de la fijación sea plana (sin fugas o azulejos que sobresalgan), que la estructura del muro sea adecuada para el montaje del producto y que no presente puntos débiles.

## DESCRIPCIÓN DE SÍMBOLOS



No utilizar silicona que contiene ácido acético!



DIMENSIONES (ver página 17)



REPUESTOS (ver página 20)

XXX = Acabados  
 000 = Cromado  
 020 = Polished Chrome  
 130 = Polished Bronze  
 140 = Brushed Bronze  
 250 = Brushed Gold-Optic  
 260 = Brushed Chrome  
 300 = Polished Redgold  
 310 = Brushed Redgold  
 330 = Polished Black Chrome  
 340 = Brushed Black Chrome  
 800 = Stainless Steel Optic  
 820 = Brushed Nickel  
 830 = Polished Nickel  
 930 = Polished Brass  
 950 = Brushed Brass  
 990 = Polished Gold-Optic

## MONTAJE

(ver página 18)



## △ VEILIGHEIDSINSTRUCTIES

- △ Bij de montage moeten ter voorkoming van knel- en snijwonden handschoenen worden gedragen.
- △ De arm van de hoofddouche is uitsluitend voor het vasthouden van de hoofddouche bedoeld en mag niet met verdere voorwerpen worden belast!

## MONTAGE-INSTRUCTIES

- / Vóór de montage moet het product gecontroleerd worden op transportschade. Na de inbouw wordt geen transport- of oppervlakteschade meer aanvaard.
- / De leidingen en armaturen moeten gemonteerd, gespoeld en gecontroleerd worden volgens de geldige normen.
- / De in de overeenkomstige landen geldende installatierichtlijnen moeten nageleefd worden.
- / Bij de montage van het product door gekwalificeerd vakpersoneel moet erop gelet worden dat het montagevlak in het volledige bereik van de bevestiging vlak is (geen uitstekende voegen of verspringende tegels), dat de wand geschikt is voor de montage van het product en geen zwakke plaatsen vertoont.

## SYMBOOLBESCHRIJVING



Gebruik geen zuurhoudende siliconen!



MATEN (zie blz. 17)



SERVICE ONDERDELEN  
(zie blz. 20)

XXX = Kleuren  
 000 = Verchromd  
 020 = Polished Chrome  
 130 = Polished Bronze  
 140 = Brushed Bronze  
 250 = Brushed Gold-Optic  
 260 = Brushed Chrome  
 300 = Polished Redgold  
 310 = Brushed Redgold  
 330 = Polished Black Chrome  
 340 = Brushed Black Chrome  
 800 = Stainless Steel Optic  
 820 = Brushed Nickel  
 830 = Polished Nickel  
 930 = Polished Brass  
 950 = Brushed Brass  
 990 = Polished Gold-Optic

## MONTAGE

(zie blz. 18)



## △ SIKKERHEDSANVISNINGER

- △ Ved monteringen skal der bruges handsker for at undgå kvæstelser og snitsår.
- △ Stangen til hovedbruseren er kun beregnet til at holde hovedbruseren. Den må ikke belastes med andre genstande!

## MONTERINGSANVISNINGER

- / Før monteringen skal produktet kontrolleres for transportskader. Efter monteringen godkendes transportskader eller skader på overfladen ikke længere.
- / Ledningerne og armaturerne skal monteres, skylles og kontrolleres iht. de gældende standarder.
- / Installationsbestemmelserne, der gælder i det enkelte land, skal overholdes.
- / Ved montering af produktet igennem kvalificerede fagfolk skal der holdes øje med, at fastgørelsesoverfladen er plan i alle områder hvor produktet monteres (ingen fremragende fuger eller fliseforskydninger), at væggene er velegnet til monteringen af produktet og ikke har svare områder.

## SYMBOLBESKRIVELSE

 Der må ikke benyttes eddikesyreholdig silikone!

 MÅLENE (se s. 17)

 RESERVEDELE (se s. 20)

- XXX = Overflade
- 000 = Krom
- 020 = Polished Chrome
- 130 = Polished Bronze
- 140 = Brushed Bronze
- 250 = Brushed Gold-Optic
- 260 = Brushed Chrome
- 300 = Polished Redgold
- 310 = Brushed Redgold
- 330 = Polished Black Chrome
- 340 = Brushed Black Chrome
- 800 = Stainless Steel Optic
- 820 = Brushed Nickel
- 830 = Polished Nickel
- 930 = Polished Brass
- 950 = Brushed Brass
- 990 = Polished Gold-Optic

## MONTERING

(se s. 18) 

## △ AVISOS DE SEGURANÇA

- △ Durante a montagem devem ser utilizadas luvas de protecção, de modo a evitar ferimentos resultantes de entalamentos e de cortes.
- △ O braço do chuveiro foi concebido apenas para servir de apoio à cabeça do chuveiro, pelo que não pode ser sujeito a cargas de objectos adicionais!

## AVISOS DE MONTAGEM

- / Antes da montagem deve-se controlar o produto relativamente a danos de transporte. Após a montagem não são aceites quaisquer danos de transporte ou de superfície.
- / As tubagens e a torneira têm que ser montadas, enxaguadas e verificadas de acordo com as normas em vigor.
- / A prescrições de instalação válidas nos respetivos países devem ser respeitadas.
- / Durante a montagem efectuada por técnicos qualificados deve ter-se em atenção que a superfície de fixação seja plana em toda a sua extensão (sem juntas ou ladrilhos salientes), que a estrutura da parede seja adequada para a montagem do produto e que não apresente pontos fracos.

## DESCRIÇÃO DO SÍMBOLO

 Não utilizar silicone que contenha ácido acético!

 MEDIDAS (ver página 17)

 PEÇAS DE SUBSTITUIÇÃO

- (ver página 20)
- XXX = Acabamentos
  - 000 = Cromado
  - 020 = Polished Chrome
  - 130 = Polished Bronze
  - 140 = Brushed Bronze
  - 250 = Brushed Gold-Optic
  - 260 = Brushed Chrome
  - 300 = Polished Redgold
  - 310 = Brushed Redgold
  - 330 = Polished Black Chrome
  - 340 = Brushed Black Chrome
  - 800 = Stainless Steel Optic
  - 820 = Brushed Nickel
  - 830 = Polished Nickel
  - 930 = Polished Brass
  - 950 = Brushed Brass
  - 990 = Polished Gold-Optic

## MONTAGEM

(ver página 18) 

## △ WSKAZÓWKI BEZPIECZEŃSTWA

- △ Aby uniknąć zranień na skutek zgniecenia lub przecięcia, podczas montażu należy nosić rękawice ochronne.
- △ Ramię prysznica jest przystosowane do trzymania głowicy prysznica i nie może być obciążane innymi przedmiotami!

## WSKAZÓWKI MONTAŻOWE

- / Przed montażem należy skontrolować produkt pod kątem szkód transportowych. Po montażu nie widać żadnych szkód transportowych ani szkód na powierzchni.
- / Przewody i armatura muszą być montowane, płukane i kontrolowane według obowiązujących norm.
- / Należy przestrzegać wytycznych instalacyjnych obowiązujących w danym kraju.
- / Montaż produktu musi być wykonany przez wykwalifikowanego fachowca. Powierzchnia w miejscu montażu musi być równa (bez uskoków wzgl. wzajemnie przesuniętych płytek). Ściana w miejscu montażu musi być stabilna. Dołożone w komplecie śruby i kołki rozporowe są przeznaczone do betonu.

## OPIS SYMBOLU



Nie stosować silikonów zawierających kwas octowy!



WYMIARY (patrz strona 17)



CZĘŚCI SERWISOWE

(patrz strona 20)

XXX = Kody kolorów

000 = Chrom

020 = Polished Chrome

130 = Polished Bronze

140 = Brushed Bronze

250 = Brushed Gold-Optic

260 = Brushed Chrome

300 = Polished Redgold

310 = Brushed Redgold

330 = Polished Black Chrome

340 = Brushed Black Chrome

800 = Stainless Steel Optic

820 = Brushed Nickel

830 = Polished Nickel

930 = Polished Brass

950 = Brushed Brass

990 = Polished Gold-Optic

## MONTAŻ

(patrz strona 18)



## △ BEZPEČNOSTNÍ POKYNY

- △ Pro zabránění řezným zraněním a pohmožděninám je nutné při montáži nosit rukavice.
- △ Držák sprchové hlavice je dimenzován pouze pro držení sprchové hlavice a nesmí se zatěžovat dalšími předměty!

## POKYNY K MONTÁŽI

- / Před montáží je třeba produkt zkontrolovat, zda nebyl při transportu poškozen. Po zabudování nebudou uznány žádné škody způsobené transportem nebo poškození povrchu.
- / Vedení a armatura musí být namontovány, propláchnuty a otestovány podle platných norem.
- / Je třeba dodržovat montážní pravidla platné v dané zemi.
- / Při montáži produktu kvalifikovanou osobou je třeba dbát na to, aby byla upevňovací plocha v celé oblasti upevnění rovná (žádné vyčnívající spáry nebo zapuštění obkladů), aby struktura stěny byla vhodná pro montáž produktu a neměla žádná slabá místa.

## POPIS SYMBOLŮ



Nepoužívat silikon s obsahem kyseliny octové!



ROZMĚRY (viz strana 17)



SERVISNÍ DÍLY (viz strana 20)

XXX = Kód povrchové úpravy

000 = Chrom

020 = Polished Chrome

130 = Polished Bronze

140 = Brushed Bronze

250 = Brushed Gold-Optic

260 = Brushed Chrome

300 = Polished Redgold

310 = Brushed Redgold

330 = Polished Black Chrome

340 = Brushed Black Chrome

800 = Stainless Steel Optic

820 = Brushed Nickel

830 = Polished Nickel

930 = Polished Brass

950 = Brushed Brass

990 = Polished Gold-Optic

## MONTÁŽ

(viz strana 18)



## △ BEZPEČNOSTNÉ POKYNY

- △ Pri montáži musíte nosiť rukavice, aby ste predišli pomliaždeninám a rezným poraneniam.
- △ Rameno držiaka hlavice sprchy je určené len na uchytienie hlavice sprchy a nesmie sa zafažovať inými predmetmi!

## POKYNY PRE MONTÁŽ

- / Pred montážou musíte produkt skontrolovať, či nebol počas transportu poškodený. Po zabudovaní nebudú uznané žiadne škody spôsobené transportom alebo poškodenia povrchu.
- / Potrubia a vybavenie musia byť namontované, prepláchnuté a vybavené v platnom normami.
- / Je potrebné dodržiavať smernice o inštalácii, ktoré sú práve teraz platné v krajinách.
- / Pri montáži produktu kvalifikovanou osobou treba dávať pozor na to, aby bola upevňovacia plocha v celej oblasti upevnenia rovná (žiadne vyčnievajúce medzery alebo zapustenia obkladov), aby štruktúra steny bola vhodná pre montáž produktu a nemá žiadne slabé miesta.

## POPIS SYMBOLOV

 Nepoužívať silikón s obsahom kyseliny octovej!

 ROZMERY (viď strana 17)

 SERVISNÉ DIELY (viď strana 20)

- XXX = Farebné označenie
- 000 = Chróm
- 020 = Polished Chrome
- 130 = Polished Bronze
- 140 = Brushed Bronze
- 250 = Brushed Gold-Optic
- 260 = Brushed Chrome
- 300 = Polished Redgold
- 310 = Brushed Redgold
- 330 = Polished Black Chrome
- 340 = Brushed Black Chrome
- 800 = Stainless Steel Optic
- 820 = Brushed Nickel
- 830 = Polished Nickel
- 930 = Polished Brass
- 950 = Brushed Brass
- 990 = Polished Gold-Optic

## △ 安全技巧

- △ 装配时为避免挤压和切割受伤，必须戴上手套。
- △ 头顶花洒夹持杆只为夹持头顶花洒而设计，不得让其承载其它物品！

## 安装提示

- / 安装前必须检查产品是否受到运输损害。安装后将不认可运输损害或表面损伤。
- / 管道和阀门必须根据通用标准进行安装、冲洗和检查。
- / 请遵守当地国家现行的安装规定。
- / 由有资格的专业人员进行产品安装时请注意：在所有加固区域中，加固表面是否平整（无突出的接缝或瓷砖），墙体结构是否适合产品安装且未显露出任何缺点。

## 符号说明

 请勿使用含有乙酸的硅胶！

 大小 (参见第 17 页)

 备用零件 (参见第 20 页)

- XXX = 颜色代码
- 000 = 镀铬
- 020 = Polished Chrome
- 130 = Polished Bronze
- 140 = Brushed Bronze
- 250 = Brushed Gold-Optic
- 260 = Brushed Chrome
- 300 = Polished Redgold
- 310 = Brushed Redgold
- 330 = Polished Black Chrome
- 340 = Brushed Black Chrome
- 800 = Stainless Steel Optic
- 820 = Brushed Nickel
- 830 = Polished Nickel
- 930 = Polished Brass
- 950 = Brushed Brass
- 990 = Polished Gold-Optic

## MONTÁŽ

(viď strana 18)



## 安装

(参见第 18 页)



## △ УКАЗАНИЯ ПО ТЕХНИКЕ БЕЗОПАСНОСТИ

- △ Во время монтажа следует надеть перчатки во избежание прищемления и порезов.
- △ Кронштейн верхнего душа предназначен только для подсоединения верхнего душа. Запрещается подвешивать на него другие предметы!

## УКАЗАНИЯ ПО МОНТАЖУ

- / Перед монтажом следует проверить изделие на предмет повреждений при перевозке. После монтажа претензии о возмещении ущерба за повреждения при перевозке или повреждения поверхностей не принимаются.
- / Трубы и арматура должны быть установлены, промыты и проверены в соответствии с действующими нормами.
- / Необходимо соблюдать требования по монтажу, действующие в соответствующих странах.
- / Во время монтажа изделия квалифицированным персоналом поверхность крепления должна быть ровной по всей области крепления (не допускайте выступающих стыков или перекоса облицовочной плитки); для монтажа изделия следует использовать подходящую стену достаточной прочности.

## ОПИСАНИЕ СИМВОЛОВ

 Не применяйте силикон, содержащий уксусную кислоту.

 РАЗМЕРЫ (см. стр. 17)

 КОМПЛЕКТ (см. стр. 20)

XXX = Цветная кодировка  
 000 = Хром  
 020 = Polished Chrome  
 130 = Polished Bronze  
 140 = Brushed Bronze  
 250 = Brushed Gold-Optic  
 260 = Brushed Chrome  
 300 = Polished Redgold  
 310 = Brushed Redgold  
 330 = Polished Black Chrome  
 340 = Brushed Black Chrome  
 800 = Stainless Steel Optic  
 820 = Brushed Nickel  
 830 = Polished Nickel  
 930 = Polished Brass  
 950 = Brushed Brass  
 990 = Polished Gold-Optic

## МОНТАЖ

(см. стр. 18)



## △ TURVALLISUUSOHJEET

- △ Asennuksessa on käytettävä käsiineitä puristumien ja viiltojen aiheuttamien tapaturmien estämiseksi.
- △ Pääsuihkun varsi on tarkoitettu vain kannattamaan pääsuihkua. Sitä ei saa kuormittaa muilla esineillä!

## A SENNUSOHJEET

- / Ennen asennusta on tarkastettava tuotteen mahdolliset kuljetusvahingot. Asennuksen jälkeen kuljetus- ja pintavaurioita ei hyväksytä.
- / Putket ja hana on asennettava, huuhdeltava ja tarkastettava voimassa olevien standardien mukaisesti.
- / Jokaisessa maassa on noudatettava siellä päteviä asennusohjeita.
- / Pätevän ammattihenkilöstön asentaessa tuotetta on otettava huomioon, että kiinnityspinnan on oltava koko kiinnitysalueelta tasainen (ei korkeita saumoja tai laattojen yhtymäkohtia), seinän rakenne soveltuu tuotteen asennukseen eikä siinä ole heikkoja kohtia.

## MERKIN KUVAUS

 Älä käytä etikkahappopitoista silikonia!

 MITAT (katso sivu 17)

 VARAOSAT (katso sivu 20)

XXX = Värikoodaus  
 000 = Kromi  
 020 = Polished Chrome  
 130 = Polished Bronze  
 140 = Brushed Bronze  
 250 = Brushed Gold-Optic  
 260 = Brushed Chrome  
 300 = Polished Redgold  
 310 = Brushed Redgold  
 330 = Polished Black Chrome  
 340 = Brushed Black Chrome  
 800 = Stainless Steel Optic  
 820 = Brushed Nickel  
 830 = Polished Nickel  
 930 = Polished Brass  
 950 = Brushed Brass  
 990 = Polished Gold-Optic

## A SENNUS

(katso sivu 18)





## △ SÄKERHETSANVISNINGAR

- △ Handskar ska bäras under monteringsarbetet så att man kan undvika kläm- och skärskador.
- △ Armen som håller huvudduschen är bara konstruerad för detta; den får inte belastas med andra föremål

## MONTERINGSANVISNINGAR

- / Det måste undersökas om produkten har transportskador innan den monteras. Efter monteringen accepteras inga transport- eller ytskiktsskador.
- / Ledningarna och blandaren måste monteras, spolats igenom och kontrolleras enligt de gällande normerna.
- / De installationsriktlinjer som gäller i länderna ska följas.
- / När kvalificerad fackpersonal monterar produkten är det viktigt att fästytan är plan över hela fastsättningsområdet (inga fogar som sticker ut eller kakelförskjutning) och att väggstrukturen är lämplig för en montering av produkten och inte har några svaga punkter.

## SYMBOLFÖRKLARING

 Använd inte silikon som innehåller ättiksyra!

 MÅTTEN (se sidan 17)

 RESERVDLAR (se sidan 20)

XXX = Färgkodning

000 = Krom

020 = Polished Chrome

130 = Polished Bronze

140 = Brushed Bronze

250 = Brushed Gold-Optic

260 = Brushed Chrome

300 = Polished Redgold

310 = Brushed Redgold

330 = Polished Black Chrome

340 = Brushed Black Chrome

800 = Stainless Steel Optic

820 = Brushed Nickel

830 = Polished Nickel

930 = Polished Brass

950 = Brushed Brass

990 = Polished Gold-Optic

## △ SAUGUMO TECHNIKOS NURODYMAI

- △ Apsaugai nuo užspaudimo ir įsijovimo montavimo metu mūvėkite pirštines.
- △ Dušo laikiklis skirtas tik dušo galvutei laikyti, todėl neturi būti apkraunamas kitokiais daiktais!

## MONTAVIMO INSTRUKCIJA

- / Prieš montuojant būtina patikrinti, ar gaminyje nebuvo pažeistas transportavimo metu. Sumontavus pretenzijos dėl transportavimo ir paviršiaus pažeidimų nepriimamos.
- / Vamzdžiai ir sujungimai turi būti montuojami, plaunami ir tikrinami pagal galiojančias normas.
- / Laikykites atitinkamoje šalyje galiojančių direktyvų dėl įrengimo.
- / Atlikdami montavimo darbus, kvalifikuoti darbuotojai turi atkreipti dėmesį, kad priivertinimo plokštuma būtų lygi (be išsikišusių siūlių ar perkreiptų plytelių), sienų konstrukcija tiktų gaminiui montuoti ir neturėtų jokių trūkumų.

## SIMBOLIO APRAŠYMAS

 Nenaudokite silikono, kurio sudėtyje yra acto rūgšties!

 IŠMATAVIMAI (žr. psl. 17)

 ATSARGINĖS DALYS (žr. psl. 20)

XXX = Spalvos

000 = Chrom

020 = Polished Chrome

130 = Polished Bronze

140 = Brushed Bronze

250 = Brushed Gold-Optic

260 = Brushed Chrome

300 = Polished Redgold

310 = Brushed Redgold

330 = Polished Black Chrome

340 = Brushed Black Chrome

800 = Stainless Steel Optic

820 = Brushed Nickel

830 = Polished Nickel

930 = Polished Brass

950 = Brushed Brass

990 = Polished Gold-Optic

## MONTERING

(se sidan 18)



## MONTAVIMAS

(žr. psl. 18)



### △ SIGURNOSNE UPUTE

- △ Prilikom montaže se radi sprječavanja prignječenja i posjekotina moraju nositi rukavice.
- △ Nosač tuša iznad glave je dimenzioniran samo za držanje danog tuša i ne smije se opterećivati drugim predmetima!

### UPUTE ZA MONTAŽU

- / Prije montaže mora se provjeriti je li proizvod oštećen prilikom transporta. Nakon ugradnje se ne priznaju nikakve reklamacije koje se odnose na površinska i transportna oštećenja.
- / Cijevi i armatura moraju biti postavljeni, isprani i testirani prema važećim normama.
- / Obvezno se moraju uvažiti propisi o instalacijama koji vrijede u dotičnoj zemlji.
- / Kada proizvod montira kvalificirano stručno osoblje treba paziti da čitava površina na koju se učvršćuje bude ravna (bez istaknutih fuga ili krivljenja pločica), da je zidna konstrukcija primjerena montaži proizvoda te da nema slabih mjesta.

### OPIS SIMBOLA



Nemojte koristiti silikon koji sadrži octenu kiselinu!



MJERE (pogledaj stranicu 17)



#### REZERVNI DJELOVI

(pogledaj stranicu 20)

- XXX = Boje
- 000 = Krom
- 020 = Polished Chrome
- 130 = Polished Bronze
- 140 = Brushed Bronze
- 250 = Brushed Gold-Optic
- 260 = Brushed Chrome
- 300 = Polished Redgold
- 310 = Brushed Redgold
- 330 = Polished Black Chrome
- 340 = Brushed Black Chrome
- 800 = Stainless Steel Optic
- 820 = Brushed Nickel
- 830 = Polished Nickel
- 930 = Polished Brass
- 950 = Brushed Brass
- 990 = Polished Gold-Optic

### SASTAVLJANJE

(pogledaj stranicu 18)



### △ GÜVENLİK UYARILARI

- △ Montaj esnasında ezilme ve kesilme gibi yaralanmaları önlemek için eldiven kullanılmalıdır.
- △ Başlıklı püskürtücü kolu yalnızca başlıklı püskürtücünün tutulması için tasarlanmıştır, başka nesnelere üzerine yük bindirilmemelidir!

### MONTAJ AÇIKLAMALARI

- / Montaj işleminden önce ürün nakliye hasarları yönünden kontrol edilmelidir. Montaj işleminden sonra nakliye veya yüzey hasarları için sorumluluk üstlenilmemektedir.
- / Boruların ve armatürün montajı, yıkanması ve kontrolü geçerli normlara göre yapılmalıdır.
- / Ülkelerde geçerli kurulum yönetmeliklerine riayet edilmelidir.
- / Ürünün yetkili uzman personel tarafından montajı yapılırken, sabitleme yüzeyinin sabitleme planının tüm alanında bulunduğu (derz veya fayans kayması olmamalıdır), duvar yapısının ürünün montajı için uygun olduğuna ve zayıf noktaları bulunmadığına dikkat edilmelidir.

### SİMGE AÇIKLAMASI



Asetik asit içeren silikon kullanmayın!



ÖLÇÜLERİ (bakınız sayfa 17)



#### YEDEK PARÇALAR (bakınız sayfa 20)

- XXX = Renkler
- 000 = Krom
- 020 = Polished Chrome
- 130 = Polished Bronze
- 140 = Brushed Bronze
- 250 = Brushed Gold-Optic
- 260 = Brushed Chrome
- 300 = Polished Redgold
- 310 = Brushed Redgold
- 330 = Polished Black Chrome
- 340 = Brushed Black Chrome
- 800 = Stainless Steel Optic
- 820 = Brushed Nickel
- 830 = Polished Nickel
- 930 = Polished Brass
- 950 = Brushed Brass
- 990 = Polished Gold-Optic

### MONTAJI

(bakınız sayfa 18)



## Δ INSTRUȚIUNI DE SIGURANȚĂ

- Δ La montare utilizați mănuși pentru evitarea contuziunilor și tăierii mâinilor.
- Δ Brațul parei de duș este destinat doar pentru a susține para, acesta nu poate fi prevăzut cu alte obiecte.

## INSTRUȚIUNI DE MONTARE

- / Înainte de instalare verificați, dacă produsul prezintă deteriorări de transport. După instalare garanția nu acoperă deteriorările de transport și cele de suprafață.
- / Conductele și bateriile trebuie montate, spălate și verificate conform normelor în vigoare.
- / Respectați reglementările referitoare la instalare valabile în țara respectivă.
- / La montarea produsului de către un personal calificat se va avea grijă ca suprafața de fixare să fie plană pe toată aria de fixare (fără proeminențe ale rosturilor sau îmbinării între plăcile de faianță) și ca structura peretelui să fie corespunzătoare pentru fixarea produsului, să nu prezinte locuri cu rezistență redusă.

## DESCRIEREA SIMBOLURILOR

 Nu utilizați silicon cu conținut de acid acetic!

 DIMENSIUNI (vezi pag. 17)

 PIESE DE SCHIMB (vezi pag. 20)

XXX = Coduri de culori  
 000 = Crom  
 020 = Polished Chrome  
 130 = Polished Bronze  
 140 = Brushed Bronze  
 250 = Brushed Gold-Optic  
 260 = Brushed Chrome  
 300 = Polished Redgold  
 310 = Brushed Redgold  
 330 = Polished Black Chrome  
 340 = Brushed Black Chrome  
 800 = Stainless Steel Optic  
 820 = Brushed Nickel  
 830 = Polished Nickel  
 930 = Polished Brass  
 950 = Brushed Brass  
 990 = Polished Gold-Optic

## Δ ΥΠΟΔΕΙΞΕΙΣ ΑΣΦΑΛΕΙΑΣ

- Δ Για να αποφύγετε τραυματισμούς κατά τη συναρμολόγηση πρέπει να φοράτε γάντια.
- Δ Ο βραχιόνος του ντους κεφαλιού έχει μελετηθεί μόνο για να κρατά το ντους κεφαλιού, δεν επιτρέπεται να φορτιζεται με άλλα αντικείμενα!

## ΟΔΗΓΙΕΣ ΣΥΝΑΡΜΟΛΟΓΗΣΗΣ

- / Πριν τη συναρμολόγηση πρέπει να εξεταστεί το προϊόν για ζημιές μεταφοράς. Μετά την εγκατάσταση δεν αναγνωρίζονται ζημιές από τη μεταφορά ή επιφανειακές ζημιές.
- / Οι σαλίνες και η μπαταρία πρέπει να τοποθετηθούν σύμφωνα με τα ισχύοντα πρότυπα, να τεθούν υπό πίεση και να δοκιμαστούν.
- / Θα πρέπει να τηρούνται οι οδηγίες εγκατάστασης που ισχύουν σε κάθε κράτος.
- / Κατά τη συναρμολόγηση του προϊόντος από ειδικό προσωπικό θα πρέπει να ελέγχεται με ιδιαίτερη προσοχή η επιφάνεια στερέωσης, αν είναι επίπεδη σε όλη της την επιφάνεια (δεν πρέπει να εξέχουν αρμοί ή πλακάκια), αν η υποδομή του τοίχου είναι κατάλληλη για τη στερέωση του προϊόντος και αν παρουσιάζει ασθενή σημεία.

## ΠΕΡΙΓΡΑΦΗ ΣΥΜΒΟΛΩΝ

 Μην χρησιμοποιείτε σιλικόνη που περιέχει οξικό οξύ!

 ΔΙΑΣΤΑΣΕΙΣ (βλ. Σελίδα 17)

 ΑΝΤΑΛΛΑΚΤΙΚΑ (βλ. Σελίδα 20)

XXX = Χρώματα  
 000 = Επιχρωμιωμένο  
 020 = Polished Chrome  
 130 = Polished Bronze  
 140 = Brushed Bronze  
 250 = Brushed Gold-Optic  
 260 = Brushed Chrome  
 300 = Polished Redgold  
 310 = Brushed Redgold  
 330 = Polished Black Chrome  
 340 = Brushed Black Chrome  
 800 = Stainless Steel Optic  
 820 = Brushed Nickel  
 830 = Polished Nickel  
 930 = Polished Brass  
 950 = Brushed Brass  
 990 = Polished Gold-Optic

## ΜΟΝΤΑΡΕ

(vezi pag. 18)



## ΣΥΝΑΡΜΟΛΟΓΗΣΗ

(βλ. Σελίδα 18)



## △ VARNOSTNA OPOZORILA

- △ Pri montaži je treba nositi rokavice, da se preprečijo poškodbe zaradi zmečkanja ali urezov.
- △ Nosilna roka naglavne prhe je konstruirana le za nošenje prhe in je ne smete obremeniti z drugimi predmeti!

## NAVODILA ZA MONTAŽO

- / Pred montažo je treba izdelek preveriti glede morebitnih transportnih poškodb. Po vgradnji transportne ali površinske poškodbe ne bodo več priznane.
- / Cevi in armaturo je treba montirati, izprati in preveriti po veljavnih standardih.
- / Upoštevati je treba pravilnike o inštalacijah, ki veljajo v posamezni državi.
- / Pri montaži tega proizvoda s strani kvalificiranega strokovnega osebja je treba paziti na to, da je pritrilna ploskev na celotni površini za pritrđitev gladka (brez izstopajočih fug ali zasekov ploščic), da je struktura stene primerna za montažo proizvoda in ne kaže šibkih mest.

## OPIS SIMBOLA



Ne smete uporabiti silikona, ki vsebuje ocetno kislino!



MERE (glejte stran 17)



REZERVNI DELI (glejte stran 20)

XXX = Barve  
 000 = Krom  
 020 = Polished Chrome  
 130 = Polished Bronze  
 140 = Brushed Bronze  
 250 = Brushed Gold-Optic  
 260 = Brushed Chrome  
 300 = Polished Redgold  
 310 = Brushed Redgold  
 330 = Polished Black Chrome  
 340 = Brushed Black Chrome  
 800 = Stainless Steel Optic  
 820 = Brushed Nickel  
 830 = Polished Nickel  
 930 = Polished Brass  
 950 = Brushed Brass  
 990 = Polished Gold-Optic

## MONTAŽA

(glejte stran 18)



## △ OHUTUSJUHISED

- △ Kandke paigaldamisel muljumis- ja lõikevigastuste vältimiseks kindaid.
- △ Dušipea hoidik on mõeldud ainult dušipea hoidmiseks ja seda ei tohi muude esemetega koormata!

## PAIGALDAMISJUHISED

- / Enne paigaldamist tuleb toodet kontrollida transportikahjustuste osas. Pärast paigaldamist ei tunnustata enam transporti- või pinnakahjustuste kaebuseid.
- / Voolikute ja segisti paigaldamisel, loputamisel ja kontrollimisel tuleb lähtuda kehtivatest normatiividest.
- / Vastavas riigis kehtivaid paigalduseeskirju tuleb järgida.
- / Toote paigaldamisel kvalifitseeritud spetsialistide poolt tuleb jälgida, et kinnituspind oleks kogu ulatuses ühtlaselt tasane (mitte ühtki üleseisvat vuuki või kaldus kahhelkivi), seina ülesehitus toote paigaldamiseks sobiv ja ilma nõrkade kohtadeta.

## SÜMBOLITE KIRJELDUS



Ärge kasutage äädikhapet sisaldavat silikooni!



MÕÕTUDE (vt lk 17)



VARUOSAD (vt lk 20)

XXX = Värvid  
 000 = Kroom  
 020 = Polished Chrome  
 130 = Polished Bronze  
 140 = Brushed Bronze  
 250 = Brushed Gold-Optic  
 260 = Brushed Chrome  
 300 = Polished Redgold  
 310 = Brushed Redgold  
 330 = Polished Black Chrome  
 340 = Brushed Black Chrome  
 800 = Stainless Steel Optic  
 820 = Brushed Nickel  
 830 = Polished Nickel  
 930 = Polished Brass  
 950 = Brushed Brass  
 990 = Polished Gold-Optic

## PAIGALDAMINE

(vt lk 18)



## △ DROŠĪBAS NORĀDES

- △ Montāžas laikā, lai izvairītos no saspiedumiem un iegriezumiem, nepieciešams nēsāt cimdus.
- △ Galvas dušas statīvs paredzēts vienīgi galvas dušas atbalstīšanai, to nedrīkst noslogot ar citiem priekšmetiem!

## NORĀDĪJUMI MONTĀŽAI

- / Pirms montāžas nepieciešams pārbaudīt, vai produktam transportēšanas laikā nav radušies bojājumi. Pēc iebūvēšanas bojājumi, kas radušies transportēšanas laikā, vai virsmas bojājumi netiek atzīti.
- / Cauruļvadi un armatūra ir jāuzstāda, jāizskalo un jāpārbauda saskaņā ar spēkā esošajiem standartiem.
- / Jāievēro attiecīgās valsts spēkā esošās montāžas prasības.
- / Kvalificētiem speciālistiem, montējot produktu, jāpiegriež vērība tam, lai piestiprināšanas virsma visā piestiprināšanas zonā ir gluda (nav fūgu vai fližu iecirtumu), sienas uzbūve ir piemērota produkta montāžai un tajā nav nestabilu vietu.

## SIMBOLU NOZĪME

 Neizmantojiet silikonu, kas satur etiķskābi!

 IZMĒRUS (skat. lpp. 17)

 REZERVES DAĻAS (skat. lpp. 20)

XXX = Krāsu kodi

000 = Hroma

020 = Polished Chrome

130 = Polished Bronze

140 = Brushed Bronze

250 = Brushed Gold-Optic

260 = Brushed Chrome

300 = Polished Redgold

310 = Brushed Redgold

330 = Polished Black Chrome

340 = Brushed Black Chrome

800 = Stainless Steel Optic

820 = Brushed Nickel

830 = Polished Nickel

930 = Polished Brass

950 = Brushed Brass

990 = Polished Gold-Optic

## △ SIGURNOSNE NAPOMENE

- △ Prilikom montaže se radi sprečavanja prignječenja i posekotina moraju nositi rukavice.
- △ Nosač tuša iznad glave je dimenzioniran samo za držanje datog tuša i ne sme se opterećivati drugim predmetima!

## INSTRUKCIJE ZA MONTAŽU

- / Pre montaže se mora proveriti da li je proizvod oštećen pri transportu. Nakon ugradnje se ne priznaju nikakve reklamacije koje se odnose na površinska i transportna oštećenja.
- / Vodovi i armatura moraju biti postavljeni, isprani i testirani prema važećim normama.
- / Treba se pridržavati propisa koji u određenim zemljama važe za instalacije.
- / Kada proizvod montira kvalifikovano stručno osoblje treba paziti da čitava površina na koju se učvršćuje bude ravna (bez istaknutih fuga ili kviljenja pločica), da je zidna konstrukcija primerena montaži proizvoda i da nema slabih mesta.

## OPIS SIMBOLA

 Nemojte koristiti silikon koji sadrži sirćetnu kiselinu!

 MERE (vidi stranu 17)

 REZERVNI DELOVI (vidi stranu 20)

XXX = Oznake boja

000 = Hrom

020 = Polished Chrome

130 = Polished Bronze

140 = Brushed Bronze

250 = Brushed Gold-Optic

260 = Brushed Chrome

300 = Polished Redgold

310 = Brushed Redgold

330 = Polished Black Chrome

340 = Brushed Black Chrome

800 = Stainless Steel Optic

820 = Brushed Nickel

830 = Polished Nickel

930 = Polished Brass

950 = Brushed Brass

990 = Polished Gold-Optic

## MONTĀŽA

(skat. lpp. 18)



## MONTAŽA

(vidi stranu 18)



## ⚠ SIKKERHETSHENVISNINGER

- ⚠ Bruk hansker under montasjen for å unngå klem- og kuttskader.
- ⚠ Armen til hodedusjen er kun laget for å holde hodedusjen. Den må ikke belastes med andre gjenstander!

## MONTAGEHENVISNINGER

- / Før montasjen skal produktet sjekkes for transportskader. Etter monteringen aksepteres ikke noen transport- eller overflateskader.
- / Ledningene og armaturen skal monteres, spyles og sjekkes iht. de gyldige normer.
- / Gjeldende retningslinjer for rørleggerarbeid i de enkelte land skal følges.
- / Under monteringen av produktet gjort av kvalifisert fagpersonell, skal man påse at monteringsoverflaten på hele festeområdet er plant (ingen utstikkende fuger eller flisekanter), at veggoppbyggingen egner seg for produktmontasjen og ikke viser svake punkter.

## SYMBOLBESKRIVELSE



Ikke bruk silikon som inneholder eddiksyre!



MÅL (se side 17)



SERVICEDELER (se side 20)

XXX = Fargekode  
 000 = Krom  
 020 = Polished Chrome  
 130 = Polished Bronze  
 140 = Brushed Bronze  
 250 = Brushed Gold-Optic  
 260 = Brushed Chrome  
 300 = Polished Redgold  
 310 = Brushed Redgold  
 330 = Polished Black Chrome  
 340 = Brushed Black Chrome  
 800 = Stainless Steel Optic  
 820 = Brushed Nickel  
 830 = Polished Nickel  
 930 = Polished Brass  
 950 = Brushed Brass  
 990 = Polished Gold-Optic

## MONTASJE

(se side 18)



## ⚠ УКАЗАНИЯ ЗА БЕЗОПАСНОСТ

- ⚠ При монтажа трябва да се носят ръкавици, за да се избегнат наранявания поради притискане или порязване.
- ⚠ Рамото на разпръсквателя за главата е разработана само, за да държи разпръсквателя за главата, то не бива да се натоварва с други предмети!

## УКАЗАНИЯ ЗА МОНТАЖ

- / Преди монтажа продуктът трябва да се провери за транспортни щети. След монтажа не се признават транспортни или повърхностни щети.
- / Тръбопроводите и арматурата трябва да се монтира, промият и проверят в съответствие с валидните норми.
- / Трябва да бъдат спазвани валидните в съответните страни предписания за инсталиране.
- / При монтаж на продукта от квалифицирани специалисти да се внимава за това, закрепващата повърхност в целия диапазон на закрепването да бъде равна (без изпъкнали fugи или изместване на плочки), конструкцията на стената да е подходяща за монтаж на продукта и да няма слаби места.

## ОПИСАНИЕ НА СИМВОЛИТЕ



Не използвайте силикон, съдържащ оцетна киселина!



РАЗМЕРИ (вижте стр. 17)



СЕРВИЗНИ ЧАСТИ (вижте стр. 20)

XXX = Цветово кодиране  
 000 = Хром  
 020 = Polished Chrome  
 130 = Polished Bronze  
 140 = Brushed Bronze  
 250 = Brushed Gold-Optic  
 260 = Brushed Chrome  
 300 = Polished Redgold  
 310 = Brushed Redgold  
 330 = Polished Black Chrome  
 340 = Brushed Black Chrome  
 800 = Stainless Steel Optic  
 820 = Brushed Nickel  
 830 = Polished Nickel  
 930 = Polished Brass  
 950 = Brushed Brass  
 990 = Polished Gold-Optic

## МОНТАЖ

(вижте стр. 18)



## △ UDHËZIME SIGURIE

- △ Për të evituar lëndimet e pickimeve ose të prerjeve gjatë procesit të montimit duhet që të vishni doreza.
- △ Mbjajtësja e kokës së dushit është projektuar vetëm për mbajtjen e kokës së dushit dhe nuk duhet që të rëndohet me objekte të tjera!

## UDHËZIME PËR MONTIMIN

- / Përpara montimit duhet që produkti të kontrollohet për dëmtime nga transporti. Pas instalimit nuk do të njihet asnjë dëmtim nga transporti ose dëmtim i sipërfaqes.
- / Tubacionet dhe rubinetet duhet që të montohen, të shpëlahen dhe të kontrollohen sipas standardeve në fuqi
- / Duhet të respektohen linjat udhëzuese të instalimit, të vlefshme për vendet respektive.
- / Gjatë montimit të produktit nga teknikët e specializuar duhet mbajtur parasysh që sipërfaqja e montimit gjendet brenda zonës së përgjithshme të planit të montimit (nuk ka vendbashkime të dala ose mospërputhje të pllakave), që struktura e murit është e përshtatshme për montimin e produktit dhe që nuk paraqet asnjë pikë të dobët.

## PËRSHKRIMI I SIMBOLIT



Mos përdorni silikon që në përbërje ka acid acetik.



PËR MASAT (shih faqen 17)



PJESËT E SERVISIT (shih faqen 20)

XXX = Kodimi me anë të ngjyrave

000 = Krom

020 = Polished Chrome

130 = Polished Bronze

140 = Brushed Bronze

250 = Brushed Gold-Optic

260 = Brushed Chrome

300 = Polished Redgold

310 = Brushed Redgold

330 = Polished Black Chrome

340 = Brushed Black Chrome

800 = Stainless Steel Optic

820 = Brushed Nickel

830 = Polished Nickel

930 = Polished Brass

950 = Brushed Brass

990 = Polished Gold-Optic

## MONTIMI

(shih faqen 18)



## △ تنبيهات الأمان

- △ يجب ارتداء قفازات الليد أثناء التركيب لتجنب حدوث أضرار الإنحشار أو الجروح
- △ وظيفة ذراع دش الرأس هي فقط الإمساك بدش الرأس، ولذلك يجب عدم التحميل عليه بأشياء أخرى.

## تعليمات التركيب

- / قبل القيام بعملية التركيب، يجب فحص المنتج للتأكد من خلوه من أية تلفيات ناتجة عن النقل بعد القيام بعملية التركيب، لن يتم الاعتراف بوجود أية تلفيات سطحية أو تلفيات ناتجة عن عملية النقل.
- / يجب تركيب وغسيل واختبار التوصيلات وخلطات المياه طبقاً للمعايير السارية.
- / يجب مراعاة القواعد الخاصة بالتركيب وأعمال السباكة وفقاً للوائح الخاصة بكل بلد.
- / عند التركيب بواسطة عمال تركيب متخصصين يجب الإلتباه إلى أن مساحة التثبيت في مكان التركيب بوجه عام مسطحة (لا توجد روابط أو فروق للربط بين البلاطات). لذا يجب التأكد من أن الحائط الذي سيتم تركيب المنتج عليه صالح لذلك وأنه لا يوجد به نقاط ضعف.

## وصف الرمز

هام! لا تستخدم السليكون الذي يحتوي على أحماض!



أبعاد (راجع صفحة 17)



قطع الغيار (راجع صفحة 20)



اللون = XXX

000 = كروم

Polished Chrome = 020

Polished Bronze = 130

Brushed Bronze = 140

Brushed Gold-Optic = 250

Brushed Chrome = 260

Polished Redgold = 300

Brushed Redgold = 310

Polished Black Chrome = 330

Brushed Black Chrome = 340

Stainless Steel Optic = 800

Brushed Nickel = 820

Polished Nickel = 830

Polished Brass = 930

Brushed Brass = 950

Polished Gold-Optic = 990

## التركيب



(راجع صفحة 18)

## △ BIZTONSÁGI UTASÍTÁSOK

- △ A szerelésnél a zúzódások és vágási sérülések elkerülése érdekében kesztyűt kell viselni.
- △ A zuhanyfej karja csak a zuhanyfej tartására alkalmas, és nem szabad más tárggyal megterhelni

## SZERELÉSI UTASÍTÁSOK

- / A szerelés előtt ellenőrizni kell, hogy a terméknek nincs-e szállítási sérülése. Beépítés után a szállítási- vagy felületi sérüléseket nem ismerik el.
- / A vezetékeket és a csaptelepet az érvényes szabványoknak megfelelően kell felszerelni, öblíteni és ellenőrizni
- / Az egyes országokban érvényes installációs irányelveket be kell tartani.
- / A termék képzett szakember általi felszerelése esetén ügyelni kell arra, hogy a rögzítési felület teljesen sima legyen (ne legyen kiálló fuga vagy csempe), a fal szerkezete a termék felszerelésére alkalmas legyen, és ne legyen gyenge pontja.

## SZIMBÓLUMOK LEÍRÁSA



Ne használjon ecetsavtartalmú szilikont!



MÉRETET (lásd a oldalon 17)



TARTOZÉKOK (lásd a oldalon 20)

XXX = Színkódolás  
 000 = Króm  
 020 = Polished Chrome  
 130 = Polished Bronze  
 140 = Brushed Bronze  
 250 = Brushed Gold-Optic  
 260 = Brushed Chrome  
 300 = Polished Redgold  
 310 = Brushed Redgold  
 330 = Polished Black Chrome  
 340 = Brushed Black Chrome  
 800 = Stainless Steel Optic  
 820 = Brushed Nickel  
 830 = Polished Nickel  
 930 = Polished Brass  
 950 = Brushed Brass  
 990 = Polished Gold-Optic

## SZERELÉS

(lásd a oldalon 18) 

## △ 安全上の注意

- △ 施工の際は手を挟んだり怪我をしないように、手袋をはめてください。
- △ オーバーヘッドシャワーのアームには、オーバーヘッドシャワー以外の他の物をぶら下げたり余計な力を与えないでください。

## 施工上の注意

- / 製品の施工前に輸送でのダメージがないか確認してください。施工後のキズ等のお申し出はお断りさせていただきます。
- / 配管と水栓は、関連法規に従って施工、洗浄、および試験を行ってください。
- / 施工行う地域に適用される関連法規をお守りください。
- / 適切な資格を持つ方が製品の施工を行ってください。施工面が平らであること(躯体の凹凸やタイル等の段差がないこと)、壁の構造が製品の施工に適しており必要な強度があることを確認してください。

## アイコンの説明



酢酸系シリコンをご使用にならないでください!



寸法 (次のページを参照 17)



スペーパーパーツ (次のページを参照 20)

XXX = 仕上げ色  
 000 = Chrome  
 020 = Polished Chrome  
 130 = Polished Bronze  
 140 = Brushed Bronze  
 250 = Brushed Gold-Optic  
 260 = Brushed Chrome  
 300 = Polished Redgold  
 310 = Brushed Redgold  
 330 = Polished Black Chrome  
 340 = Brushed Black Chrome  
 800 = Stainless Steel Optic  
 820 = Brushed Nickel  
 830 = Polished Nickel  
 930 = Polished Brass  
 950 = Brushed Brass  
 990 = Polished Gold-Optic

## 施工方法

(次のページを参照 18) 





AXOR Montreux  
27348XXX

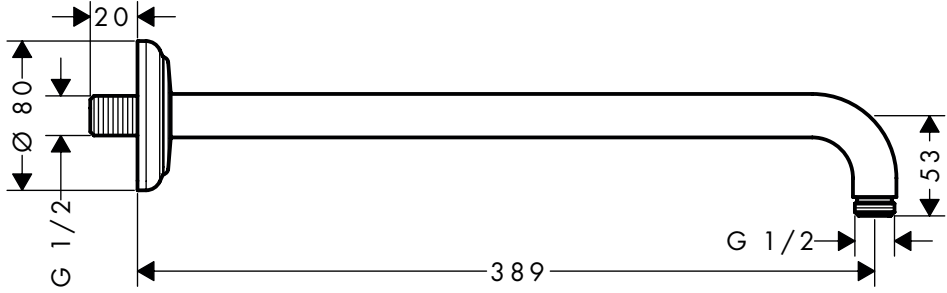

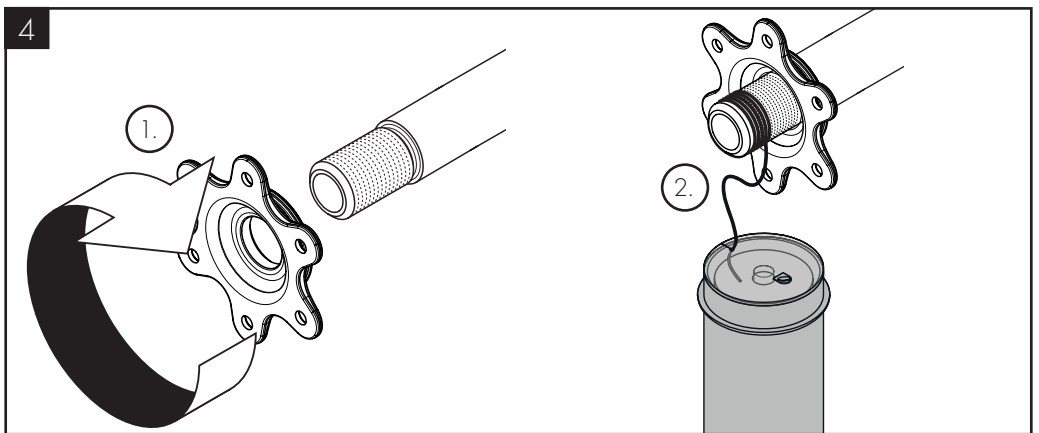
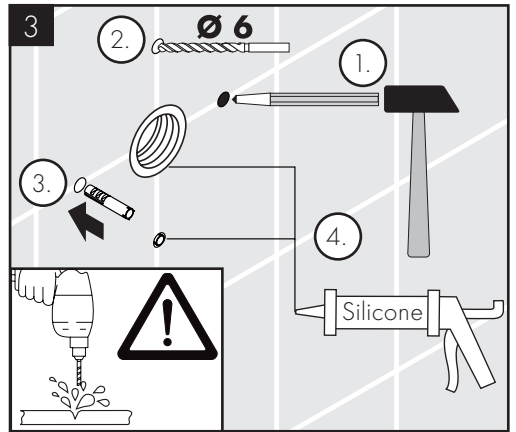
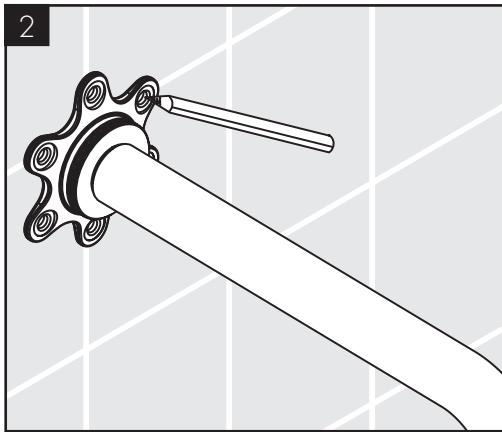
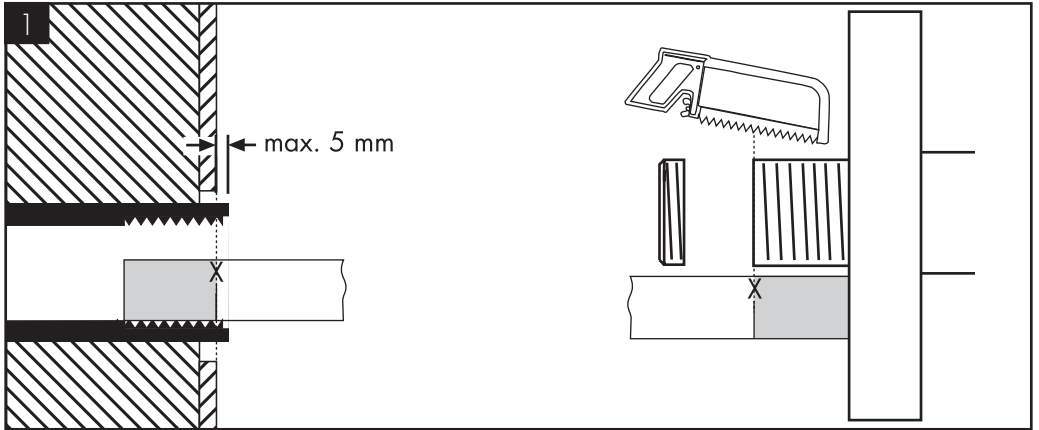

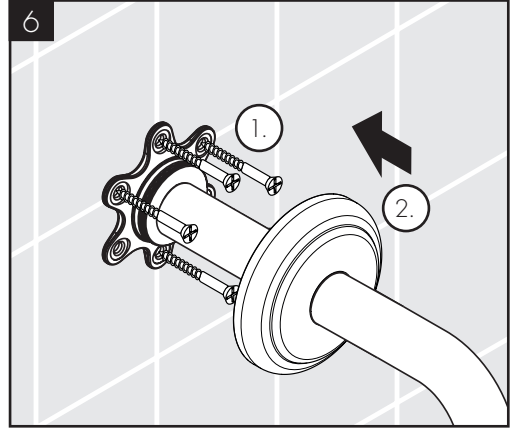
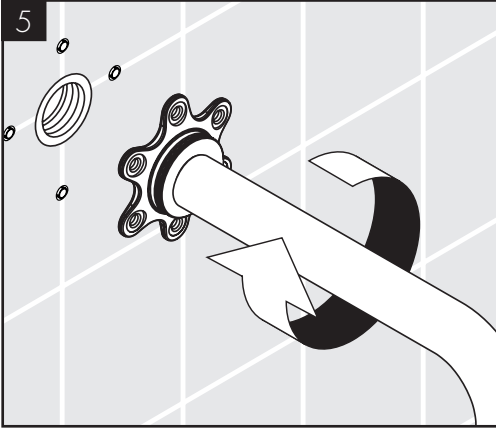

# AXOR

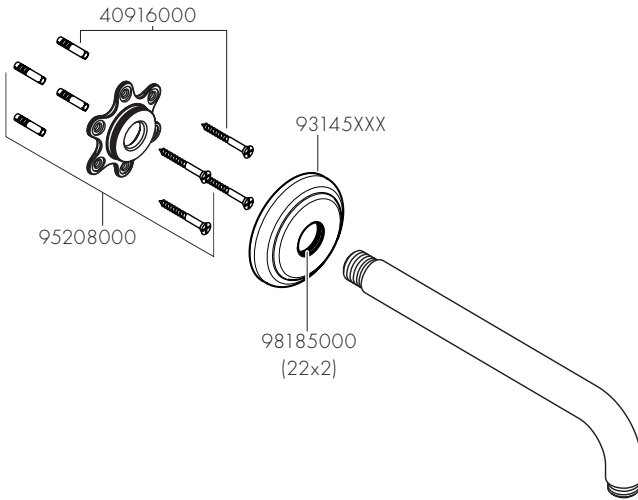

AXOR / Hansgrohe SE  
Austraße 5-9  
77761 Schiltach  
Deutschland

info@axor-design.com  
axor-design.com