

AXOR

DE / Gebrauchsanleitung / Montageanleitung	02
FR / Mode d'emploi / Instructions de montage	03
EN / Instructions for use / Assembly instructions	04
IT / Istruzioni per l'uso / Istruzioni per Installazione	05
ES / Modo de empleo / Instrucciones de montaje	06
NL / Gebruiksaanwijzing / Handleiding	07
DK / Brugsanvisning / Monteringsvejledning	08
PT / Instruções para uso / Manual de Instalação	09
PL / Instrukcja obsługi / Instrukcja montażu	10
CS / Návod k použití / Montážní návod	11
SK / Návod na použitie / Montážny návod	12
ZH / 用户手册 / 组装说明	13
RU / Руководство пользователя / Инструкция по монтажу	14
FI / Käyttöohje / Asennusohje	15
SV / Bruksanvisning / Monteringsanvisning	16
LT / Vartotojo instrukcija / Montavimo instrukcijos	17
HR / Upute za uporabu / Uputstva za instalaciju	18
TR / Kullanım kılavuzu / Montaj kılavuzu	19
RO / Manual de utilizare / Instrucțiuni de montare	20
EL / Οδηγίες χρήσης / Οδηγία συναρμολόγησης	21
SL / Navodilo za uporabo / Navodila za montažo	22
ET / Kasutusjuhend / Paigaldusjuhend	23
LV / Lietošanas pamācība / Montāžas instrukcija	24
SR / Uputstvo za upotrebu / Uputstvo za montažu	25
NO / Bruksanvisning / Montasjeveiledning	26
BG / Инструкция за употреба / Ръководство за монтаж	27
SQ / Udhëzuesi i përdorimit / Udhëzime rreth montimit	28
AR / دليل الاستخدام / تعليمات التجميع	29
HU / Használati útmutató / Szerelési útmutató	30
JP / 取扱説明書 / 施工説明書	31

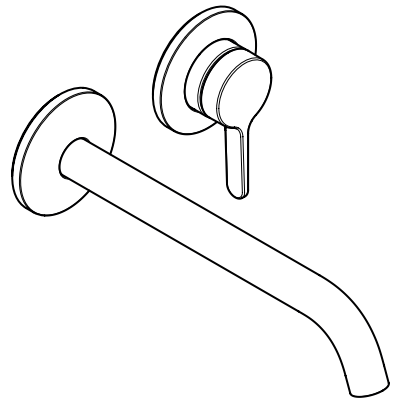

AXOR One
48120XXX

INSTALLATION

△ SICHERHEITSHINWEISE

- △ Bei der Montage müssen zur Vermeidung von Quetsch- und Schnittverletzungen Handschuhe getragen werden.
- △ Das Produkt darf nur zu Bade-, Hygiene- und Körperreinigungszwecken eingesetzt werden.
- △ Große Druckunterschiede zwischen den Kalt- und Warmwasseranschlüssen müssen ausgeglichen werden.

MONTAGEHINWEISE

- / Vor der Montage muss das Produkt auf Transportschäden untersucht werden. Nach dem Einbau werden keine Transport- oder Oberflächenschäden anerkannt.
- / Die Leitungen und die Armatur müssen nach den gültigen Normen montiert, gespült und geprüft werden.
- / Die in den Ländern jeweils gültigen Installationsrichtlinien sind einzuhalten.
- / Das Ablaufventil darf nur zum bestimmungsgemäßen Gebrauch verwendet werden. Das Befestigen von anderen Gegenständen z. B. einer Halbsäule an dem Ablaufventil ist nicht zulässig.
- / Bei Problemen mit dem Durchlauferhitzer oder wenn mehr Wasserdurchsatz gewünscht wird, kann der EcoSmart® (Durchflussbegrenzer), der hinter dem Luftsprudler sitzt, entfernt werden.

TECHNISCHE DATEN

Armatur serienmäßig mit EcoSmart® (Durchflussbegrenzer)	
Betriebsdruck:	max. 1 MPa
Empfohlener Betriebsdruck:	0,1 - 0,5 MPa
Prüfdruck:	1,6 MPa
	(1 MPa = 10 bar = 147 PSI)
Heißwassertemperatur:	max. 60°C
Thermische Desinfektion:	70°C / 4 min

Das Produkt ist ausschließlich für Trinkwasser konzipiert!

SYMBOLERKLÄRUNG

Kein essigsäurehaltiges Silikon verwenden!



JUSTIERUNG (siehe Seite 36)

Einstellen der Warmwasserbegrenzung. In Verbindung mit Durchlauferhitzern ist eine Warmwassersperre nicht zu empfehlen.



MASSE (siehe Seite 37)

**DURCHFLUSSDIAGRAMM**

(siehe Seite 37)

① mit EcoSmart®

② ohne EcoSmart®



Serviceteile (siehe Seite 39)

XXX = Farbcodierung

000 = Chrom

020 = Polished Chrome

130 = Polished Bronze

140 = Brushed Bronze

250 = Brushed Gold-Optic

260 = Brushed Chrome

300 = Polished Redgold

310 = Brushed Redgold

330 = Polished Black Chrome

340 = Brushed Black Chrome

670 = Mattschwarz

800 = Edelstahl-Optik

820 = Brushed Nickel

830 = Polished Nickel

930 = Polished Brass

950 = Brushed Brass

990 = Polished Gold-Optic

SONDERZUBEHÖR

(nicht im Lieferumfang enthalten)



Verlängerung 25 mm #13971000

(siehe Seite 39)



REINIGUNG (siehe Seite 38)



BEDIENUNG (siehe Seite 40)

Hansgrohe empfiehlt, morgens oder nach längeren Stagnationszeiten den ersten halben Liter nicht als Trinkwasser zu verwenden.



PRÜFZEICHEN (siehe Seite 39)

MONTAGE (siehe Seite 32)



△ CONSIGNES DE SÉCURITÉ

- △ Lors du montage, porter des gants de protection pour éviter toute blessure par écrasement ou coupure.
- △ Le produit ne doit servir qu'à se laver et à assurer l'hygiène corporelle.
- △ Il est conseillé d'équilibrer les pressions de l'eau chaude et froide.

INSTRUCTIONS POUR LE MONTAGE

- / Avant son montage, s'assurer que le produit n'a subi aucun dommage pendant le transport. Après le montage, tout dommage de transport ou de surface ne pourra pas être reconnu.
- / Les conduites et la robinetterie doivent être montés, rincés et contrôlés selon les normes en vigueur.
- / Les directives d'installation en vigueur dans le pays concerné doivent être respectées.
- / La vanne d'écoulement ne doit être utilisée qu'aux fins auxquelles elle a été conçue. La fixation d'autres objets, tels p. ex. qu'une demi-colonne, est interdite sur la vanne d'écoulement.
- / En cas de problèmes avec le chauffe-eau, ou bien si le débit d'eau doit être plus important, il est possible d'enlever l'EcoSmart® (limiteur de débit) se trouvant derrière l'aérateur.

INFORMATIONS TECHNIQUES

Robinetterie équipée en série d'un EcoSmart® (limiteur de débit)

Pression de service autorisée:	max. 1 MPa
Pression de service conseillée:	0,1 - 0,5 MPa
Pression maximum de contrôle:	1,6 MPa (1 MPa = 10 bar = 147 PSI)
Température d'eau chaude:	max. 60°C
Désinfection thermique:	70°C / 4 min

Le produit est exclusivement conçu pour de l'eau potable!

DESCRIPTION DU SYMBOLE



Ne pas utiliser de silicone contenant de l'acide acétique!



ETALONNAGE (voir pages 36)

Réglage de la limitation d'eau chaude. En liaison avec les chauffe-eau, un blocage de l'eau chaude n'est pas recommandable.



DIMENSIONS (voir pages 37)



DIAGRAMME DU DÉBIT
(voir pages 37)

① avec EcoSmart®

② sans EcoSmart®



Pièces détachées (voir pages 39)

XXX = Couleurs

000 = Chromé

020 = Polished Chrome

130 = Polished Bronze

140 = Brushed Bronze

250 = Brushed Gold-Optic

260 = Brushed Chrome

300 = Polished Redgold

310 = Brushed Redgold

330 = Polished Black Chrome

340 = Brushed Black Chrome

670 = Matt Black

800 = Aspect Acier Inox

820 = Brushed Nickel

830 = Polished Nickel

930 = Polished Brass

950 = Brushed Brass

990 = Polished Gold-Optic

ACCESSOIRES EN OPTION

(ne fait pas partie de la fourniture)



jeu de rallonge 25 mm #13971000
(voir pages 39)



NETTOYAGE (voir pages 38)



INSTRUCTIONS DE SERVICE
(voir pages 40)

Hansgrohe recommande de ne pas utiliser le premier demi-litre le matin ou après une période de stagnation prolongée.



CLASSIFICATION ACOUSTIQUE
ET DÉBIT (voir pages 39)

MONTAGE (voir pages 32)



△ SAFETY NOTES

- △ Gloves should be worn during installation to prevent crushing and cutting injuries.
- △ The product may only be used for bathing, hygienic and body cleaning purposes.
- △ The hot and cold supplies must be of equal pressures.

INSTALLATION INSTRUCTIONS

- / Prior to installation, inspect the product for transport damages. After it has been installed, no transport or surface damage will be honoured.
- / The pipes and the fixture must be installed, flushed and tested as per the applicable standards.
- / The plumbing codes applicable in the respective countries must be observed.
- / The drain valve must only be used as intended. It is not allowed to attach other objects to the drain valve, for example a semi-pedestal.
- / If the instantaneous water heater causes problems or if you wish to increase the water flow, the EcoSmart® (flow limiter) located behind the aerator can be removed.

TECHNICAL DATA

This mixer series-produced with EcoSmart® (flow limiter)

Operating pressure: max. 1 MPa

Recommended operating pressure: 0,1 - 0,5 MPa

Test pressure: 1,6 MPa

(1 MPa = 10 bar = 147 PSI)

Hot water temperature: max. 60°C

Thermal disinfection: 70°C / 4 min

The product is exclusively designed for drinking water!

SYMBOL DESCRIPTION

Do not use silicone containing acetic acid!



ADJUSTMENT (see page 36)

To adjust the hot water limiter. Using a hot water limiter in combination with a continuous flow water heater is not recommended.



DIMENSIONS (see page 37)



FLOW DIAGRAM (see page 37)

① with EcoSmart®

② without EcoSmart®



Spare parts (see page 39)

XXX = Colors

000 = Chrome Plated

020 = Polished Chrome

130 = Polished Bronze

140 = Brushed Bronze

250 = Brushed Gold-Optic

260 = Brushed Chrome

300 = Polished Redgold

310 = Brushed Redgold

330 = Polished Black Chrome

340 = Brushed Black Chrome

670 = Matt Black

800 = Stainless Steel Optic

820 = Brushed Nickel

830 = Polished Nickel

930 = Polished Brass

950 = Brushed Brass

990 = Polished Gold-Optic

SPECIAL ACCESSORIES

(order as an extra)



extension 25 mm #13971000 (see page 39)



CLEANING (see page 38)



OPERATION (see page 40)

Hansgrohe recommends not to use as drinking water the first half liter of water drawn in the morning or after a prolonged period of non-use.



TEST CERTIFICATE (see page 39)

ASSEMBLY (see page 32)



△ INDICAZIONI SULLA SICUREZZA

- △ Durante il montaggio, per evitare ferite da schiacciamento e da taglio bisogna indossare guanti protettivi.
- △ Il prodotto deve essere utilizzato esclusivamente per fare il bagno e per l'igiene del corpo.
- △ Attenzione! Compensare le differenze di pressione tra i collegamenti dell'acqua fredda e dell'acqua calda.

ISTRUZIONI PER IL MONTAGGIO

- / Prima del montaggio è necessario controllare che non ci siano stati danni durante il trasporto. Una volta eseguito il montaggio, non verranno riconosciuti eventuali danni di trasporto o delle superfici.
- / Montare, lavare e controllare tubature e rubinetteria rispettando le norme correnti.
- / Vanno rispettate le direttive di installazione nazionali vigenti nel rispettivo paese.
- / Utilizzare la valvola di scarico solo conforme alla destinazione. Non è consentito fissare altri oggetti, ad es. una semi-colonna, alla valvola di scarico.
- / Nel caso di problemi con lo scalda-acqua oppure nel caso si desiderasse più erogazione, si può eliminare il EcoSmart® (limitatore di flusso) che si trova dietro la valvola di aerazione.

DATI TECNICI

Questo miscelatore è dotato di serie del EcoSmart® (limitatore di flusso)

Pressione d'uso: max. 1 MPa
 Pressione d'uso consigliata: 0,1 - 0,5 MPa
 Pressione di prova: 1,6 MPa
 (1 MPa = 10 bar = 147 PSI)

Temperatura dell'acqua calda: max. 60°C
 Disinfezione termica: 70°C / 4 min

Il prodotto è concepito esclusivamente per acqua potabile!

DESCRIZIONE SIMBOLO



Non utilizzare silicone contenente acido acetico!



TARATURA (vedi pagg. 36)

Regolazione del limitatore di erogazione d'acqua calda. Un limitatore di erogazione di acqua calda in combinazione con le caldaie istantanee non è consigliabile.



INGOMBRI (vedi pagg. 37)



DIAGRAMMA FLUSSO
 (vedi pagg. 37)

① con EcoSmart®

② senza EcoSmart®



Parti di ricambio (vedi pagg. 39)

XXX = Trattamento

000 = Cromato

020 = Polished Chrome

130 = Polished Bronze

140 = Brushed Bronze

250 = Brushed Gold-Optic

260 = Brushed Chrome

300 = Polished Redgold

310 = Brushed Redgold

330 = Polished Black Chrome

340 = Brushed Black Chrome

670 = Matt Black

800 = Acciaio Inox Acciaio

820 = Brushed Nickel

830 = Polished Nickel

930 = Polished Brass

950 = Brushed Brass

990 = Polished Gold-Optic

ACCESSORI SPECIALI

(non contenuto nel volume di fornitura)



prolunga 25 mm #13971000 (vedi pagg. 39)



PULITURA (vedi pagg. 38)



PROCEDURA (vedi pagg. 40)

Hangrohe raccomanda, di mattina oppure dopo lunghi tempi di stagnazione, di non utilizzare il primo mezzo litro come acqua potabile.



SEGNO DI VERIFICA

(vedi pagg. 39)

MONTAGGIO (vedi pagg. 32)



△ INDICACIONES DE SEGURIDAD

- △ Durante el montaje deben utilizarse guantes para evitar heridas por aplastamiento o corte.
- △ El producto solo debe ser utilizado para fines de baño, higiene y limpieza corporal.
- △ Grandes diferencias de presión en servicio entre agua fría y agua caliente deben equilibrarse.

INDICACIONES PARA EL MONTAJE

- / Antes del montaje se debe examinar el producto contra daños de transporte. Después de la instalación no se reconoce ningún daño de transporte o de superficie.
- / Los conductos y la grifería deben montarse, lavarse y comprobarse según las normas vigentes.
- / Es obligatorio el cumplimiento de las directrices de instalación vigentes en el país respectivo.
- / La válvula de desagüe solo puede ser utilizada para el uso especificado. No se permite fijar a la válvula de desagüe otros objetos, como una semicolumna.
- / En caso de problemas con el calentador instantáneo o cuando se desee más caudal de agua puede quitarse el EcoSmart® (limitador de caudal), situado detrás del aireador.

DATOS TÉCNICOS

Grifo, desde fábrica equipado con EcoSmart® (limitador de caudal)

Presión en servicio:	max. 1 MPa
Presión recomendada en servicio:	0,1 - 0,5 MPa
Presión de prueba:	1,6 MPa (1 MPa = 10 bar = 147 PSI)

Temperatura del agua caliente:	max. 60°C
Desinfección térmica:	70°C / 4 min

El producto ha sido concebido exclusivamente para agua potable.

DESCRIPCIÓN DE SÍMBOLOS



No utilizar silicona que contiene ácido acético!



AJUSTE (ver página 36)

Ajuste del límite de agua caliente. En combinación con calentadores continuos no es recomendable utilizar un bloqueo de agua caliente.



DIMENSIONES (ver página 37)



DIAGRAMA DE CIRCULACIÓN
(ver página 37)

① con EcoSmart®

② sin EcoSmart®



Repuestos (ver página 39)

XXX = Acabados

000 = Cromado

020 = Polished Chrome

130 = Polished Bronze

140 = Brushed Bronze

250 = Brushed Gold-Optic

260 = Brushed Chrome

300 = Polished Redgold

310 = Brushed Redgold

330 = Polished Black Chrome

340 = Brushed Black Chrome

670 = Matt Black

800 = Acero Especial

820 = Brushed Nickel

830 = Polished Nickel

930 = Polished Brass

950 = Brushed Brass

990 = Polished Gold-Optic

OPCIONAL (no incluido en el suministro)



Prolongación 25 mm #13971000
(ver página 39)



LIMPIAR (ver página 38)



MANEJO (ver página 40)

Hansgrohe recomienda no utilizar el primer medio litro como agua potable por las mañanas o tras un largo periodo de inactividad.



MARCA DE VERIFICACIÓN
(ver página 39)

MONTAJE (ver página 32) 

△ VEILIGHEIDSINSTRUCTIES

- △ Bij de montage moeten ter voorkoming van knel- en snijwonden handschoenen worden gedragen.
- △ Het product mag alleen voor het wassen, hygiënische doeleinden en voor de lichaamsreiniging worden gebruikt.
- △ Grote drukverschillen tussen de koud- en warmwater-toevoer dienen vermeden te worden.

MONTAGE-INSTRUCTIES

- / Vóór de montage moet het product gecontroleerd worden op transportschade. Na de inbouw wordt geen transport- of oppervlakteschade meer aanvaard.
- / De leidingen en armaturen moeten gemonteerd, gespoeld en gecontroleerd worden volgens de geldige normen.
- / De in de overeenkomstige landen geldende installatie-richtlijnen moeten nageleefd worden.
- / De uitlaatklep mag enkel gebruikt worden voor het reglementaire gebruik. Het bevestigen van andere voorwerpen, bv. een halfzuil op de uitlaatklep is niet toegestaan.
- / Wanneer problemen optreden bij doorloopgeisers of wanneer een grotere waterdoorvoer gewenst is, kan de EcoSmart® (doorstroombegrenzer) die achter de perlator is gemonteerd, makkelijk verwijderd worden.

TECHNISCHE GEGEVENS

Armatuur standaard met EcoSmart® (doorstroombegrenzer)

Werkdruk: max. max. 1 MPa
 Aanbevolen werkdruk: 0,1 - 0,5 MPa
 Getest bij: 1,6 MPa
 (1 MPa = 10 bar = 147 PSI)

Temperatuur warm water: max. 60°C

Thermische desinfectie: 70°C/4 min

Het product is uitsluitend ontworpen voor drinkwater!

SYMBOOLBESCHRIJVING



Gebruik geen zuurhoudende silicone!



INSTELLEN (zie blz. 36)

Instellen van de warmwaterbegrenzing. In combinatie met een doorstomer is een warmwaterblokkering niet aanbevelenswaardig.



MATEN (zie blz. 37)



DOORSTROOMDIAGRAM
 (zie blz. 37)

① met EcoSmart®

② zonder EcoSmart®



Service onderdelen (zie blz. 39)

XXX = Kleuren

000 = Verchroomd

020 = Polished Chrome

130 = Polished Bronze

140 = Brushed Bronze

250 = Brushed Gold-Optic

260 = Brushed Chrome

300 = Polished Redgold

310 = Brushed Redgold

330 = Polished Black Chrome

340 = Brushed Black Chrome

670 = Matt Black

800 = RVS-look

820 = Brushed Nickel

830 = Polished Nickel

930 = Polished Brass

950 = Brushed Brass

990 = Polished Gold-Optic

TOEBEHOREN

(behoort niet tot het leveringspakket)



Verlengstuk 25 mm #13971000 (zie blz. 39)



REINIGEN (zie blz. 38)



BEDIENING (zie blz. 40)

Hansgrohe raadt aan om 's morgens na langere stagnatietijden de eerste halve liter niet als drinkwater te gebruiken.



KEURMERK (zie blz. 39)

MONTAGE (zie blz. 32)



△ SIKKERHEDSANVISNINGER

- △ Ved monteringen skal der bruges handsker for at undgå kvæstelser og snitsår.
- △ Produktet må kun bruges til bade-, hygiejne og kropsrengøringsformål.
- △ Større trykforskelle mellem koldt og varmt vand bør udjævnes.

MONTERINGSANVISNINGER

- / Før monteringen skal produktet kontrolleres for transportskader. Efter monteringen godkendes transportskader eller skader på overfladen ikke længere.
- / Ledningerne og armaturerne skal monteres, skylles og kontrolleres iht. de gældende standarder.
- / Installationsbestemmelserne, der gælder i det enkelte land, skal overholdes.
- / Afløbsventilen må kun bruges til det fastlagte formål. Det er ikke tilladt at fastgøre andre genstande f.eks. en halvsnøje til afløbsventilen.
- / Ved problemer med gennemløbsvandvarmer eller hvis der ønskes mere vandgennemstrømning, kan EcoSmart® (gennemstrømningsbegrænseren), der sidder i perlatoren, fjernes.

TEKNISKE DATA

Armaturet er forsynet med EcoSmart® (gennemstrømningsbegrænsner)

Driftstryk: max. 1 MPa
 Anbefalet driftstryk: 0,1 - 0,5 MPa
 Prøvetryk: 1,6 MPa
 (1 MPa = 10 bar = 147 PSI)

Varmtvandstemperatur: max. 60°C
 Termisk desinfektion: 70°C / 4 min

Produktet er udelukkende beregnet til drikkevand!

SYMBOLBESKRIVELSE



Der må ikke benyttes eddikesyreholdig silikone!



FORINDSTILLING (se s. 36)

Indstilling af varmvandsbegrænsningen. I forbindelse med gennemstrømningsvandvarmere anbefaler vi ikke en varmvandsspærre.



MÅLENE (se s. 37)



GENNEMSTRØMNINGSDIAGRAM (se s. 37)

⊙ med EcoSmart®

⊘ uden EcoSmart®

Reservedele (se s. 39)



XXX = Overflade

000 = Krom

020 = Polished Chrome

130 = Polished Bronze

140 = Brushed Bronze

250 = Brushed Gold-Optic

260 = Brushed Chrome

300 = Polished Redgold

310 = Brushed Redgold

330 = Polished Black Chrome

340 = Brushed Black Chrome

670 = Matt Black

800 = Stainless Steel Optic

820 = Brushed Nickel

830 = Polished Nickel

930 = Polished Brass

950 = Brushed Brass

990 = Polished Gold-Optic

SPECIALTILBEHØR

(ikke med i leveringsomfang)



Forlængersæt 25 mm #13971000 (se s. 39)



RENGØRING (se s. 38)



BRUGSANVISNING (se s. 40)

Hansgrohe anbefaler at den første halve liter om morgenen eller efter længere stagneringstider ikke anvendes som drikkevand.



GODKENDELSE (se s. 39)

MONTERING (se s. 32)



△ AVISOS DE SEGURANÇA

- △ Durante a montagem devem ser utilizadas luvas de protecção, de modo a evitar ferimentos resultantes de entalamentos e de cortes.
- △ O produto só pode ser utilizado para fins de higiene pessoal.
- △ Grandes diferenças entre as pressões das águas quente e fria devem ser compensadas.

AVISOS DE MONTAGEM

- / Antes da montagem deve-se controlar o produto relativamente a danos de transporte. Após a montagem não são aceites quaisquer danos de transporte ou de superfície.
- / As tubagens e a torneira têm que ser montadas, enxaguadas e verificadas de acordo com as normas em vigor.
- / A prescrições de instalação válidas nos respetivos países devem ser respeitadas.
- / A válvula de escoamento só pode ser utilizada para o fim para o qual foi concebida. Não é permitida a fixação de outros objetos na válvula de escoamento como, por exemplo, uma semicoluna.
- / Em caso de problemas com o esquentador de água ou se desejar maior débito de água, é possível retirar o EcoSmart® (limitador de caudal), situado por trás do emulsor.

DADOS TÉCNICOS

Misturadoras produzidas em série com EcoSmart® (limitador de caudal)

Pressão de funcionamento: max. 1 MPa

Pressão de func. recomendada: 0,1 - 0,5 MPa

Pressão testada: 1,6 MPa

(1 MPa = 10 bar = 147 PSI)

Temperatura da água quente: max. 60°C

Desinfecção térmica: 70°C/4 min

Este produto foi única e exclusivamente concebido para água potável!

DESCRIÇÃO DO SÍMBOLO



Não utilizar silicone que contenha ácido acético!



AFINAÇÃO (ver página 36)

Ajuste do limitador de água quente. Em combinação com um esquentador, não é

recomendável o uso de um bloqueio de água quente.

MEDIDAS (ver página 37)



FLUXOGRAMA (ver página 37)

① com EcoSmart®

② sem EcoSmart®



Peças de substituição (ver página 39)

XXX = Acabamentos

000 = Cromado

020 = Polished Chrome

130 = Polished Bronze

140 = Brushed Bronze

250 = Brushed Gold-Optic

260 = Brushed Chrome

300 = Polished Redgold

310 = Brushed Redgold

330 = Polished Black Chrome

340 = Brushed Black Chrome

670 = Matt Black

800 = Aço Imaculado Ótica

820 = Brushed Nickel

830 = Polished Nickel

930 = Polished Brass

950 = Brushed Brass

990 = Polished Gold-Optic

ACESSÓRIOS ESPECIAIS

(não incluído no volume de fornecimento)



Crescente 25 mm #13971000 (ver página 39)



LIMPEZA (ver página 38)



FUNCIONAMENTO (ver página 40)

A Hansgrohe recomenda a não utilização do primeiro meio litro de água, de manhã ou após longas paragens, para fins de consumo.



MARCA DE CONTROLO

(ver página 39)

MONTAGEM (ver página 32)



△ WSKAZÓWKI BEZPIECZEŃSTWA

- △ Aby uniknąć zranień na skutek zgniecenia lub przecięcia, podczas montażu należy nosić rękawice ochronne.
- △ Produkt może być używany tylko do kąpieli, higieny i czyszczenia ciała.
- △ Znaczne różnice ciśnień na dopływach ciepłej i zimnej wody muszą zostać wyrównane.

WSKAZÓWKI MONTAŻOWE

- / Przed montażem należy skontrolować produkt pod kątem szkód transportowych. Po montażu nie widać żadnych szkód transportowych ani szkód na powierzchni.
- / Przewody i armatura muszą być montowane, płukane i kontrolowane według obowiązujących norm.
- / Należy przestrzegać wytycznych instalacyjnych obowiązujących w danym kraju.
- / Zawór odpływowy można używać tylko zgodnie z przeznaczeniem. Mocowanie innych przedmiotów, np. półkolony przy zaworze odpływowym, jest niedozwolone.
- / W przypadku problemów z przepływowymi podgrzewaczami wody lub jeśli chce się uzyskać większy przepływ wody, można usunąć EcoSmart® (ogranicznik przepływu) znajdujący się za napowietrzaczem.

DANE TECHNICZNE

Armatura produkowana seryjnie z funkcją EcoSmart® (ogranicznik przepływu)

Ciśnienie robocze: maks. 1 MPa

Zalecane ciśnienie robocze: 0,1 - 0,5 MPa

Ciśnienie próbne: 1,6 MPa

(1 MPa = 10 bary = 147 PSI)

Temperatura wody gorącej: maks. 60°C

Dezynfekcja termiczna: 70°C/4 min

Produkt przeznaczony wyłącznie do wody pitnej!

OPIS SYMBOLU



Nie stosować silikonów zawierających kwas octowy!



U STAW I A N I E (patrz strona 36)

Ustawianie ogranicznika ciepłej wody.

Używanie ogranicznika temperatury wody w

połączeniu z przepływowym podgrzewaczem wody nie jest zalecane.

W Y M I A R Y (patrz strona 37)



S C H E M A T P R Z E P Ł Y W U (patrz strona 37)

① z EcoSmart®

② bez EcoSmart®



Części serwisowe (patrz strona 39)

XXX = Kody kolorów

000 = Chrom

020 = Polished Chrome

130 = Polished Bronze

140 = Brushed Bronze

250 = Brushed Gold-Optic

260 = Brushed Chrome

300 = Polished Redgold

310 = Brushed Redgold

330 = Polished Black Chrome

340 = Brushed Black Chrome

670 = Matt Black

800 = Stal Szlachetna

820 = Brushed Nickel

830 = Polished Nickel

930 = Polished Brass

950 = Brushed Brass

990 = Polished Gold-Optic

W Y P O S A Ż E N I E S P E C J A L N E

(Nie jest częścią dostawy)



Przedłużka 25 mm #13971000 (patrz strona 39)



C Z Y S Z C Z E N I E (patrz strona 38)



O B S Ł U G A (patrz strona 40)

Hansgrohe zaleca, by z rana lub po dłuższym czasie niekorzystania, pierwsze pół litra wody nie używać jako wody pitnej.



Z N A K J A K O Ś C I (patrz strona 39)

MONTAŻ (patrz strona 32)



△ BEZPEČNOSTNÍ POKYNY

- △ Pro zabránění řezným zraněním a pohmožděninám je nutné při montáži nosit rukavice.
- △ Produkt smí být používán pouze ke koupání a za účelem tělesné hygieny.
- △ Je nutné vyrovnat velké rozdíly tlaku mezi přípoji studené a teplé vody.

POKYNY K MONTÁŽI

- / Před montáží je třeba produkt zkontrolovat, zda nebyl při transportu poškozen. Po zabudování nebudou uznány žádné škody způsobené transportem nebo poškození povrchu.
- / Vedení a armatura musí být namontovány, propláchnuty a otestovány podle platných norem.
- / Je třeba dodržovat montážní pravidla platné v dané zemi.
- / Vypouštěcí ventil je povoleno používat pouze dle určení. Připevňování jiných předmětů např. polosloupů k vypouštěcímu ventilu není přípustné.
- / Při problémech s průtokovým ohřivačem, nebo když je požadován větší průtok, může být odstraněno zařízení EcoSmart® (omezovač průtoku), které je umístěno za perlátorem.

TECHNICKÉ ÚDAJE

Armatura je sériově vybavena zařízením EcoSmart® (omezovač průtoku)

Provozní tlak:	max. 1 MPa
Doporučený provozní tlak:	0,1 - 0,5 MPa
Zkušební tlak:	1,6 MPa
	(1 MPa = 10 bar = 147 PSI)
Teplota horké vody:	max. 60°C
Teplná desinfekce:	70°C / 4 min

Výrobky Hansgrohe jsou vhodné pro přímý kontakt s pitnou vodou.

POPIS SYMBOLŮ



Nepoužívat silikon s obsahem kyseliny octové!



NASTAVENÍ (viz strana 36)

Nastavení omezovače teplé vody. Ve spojení s průtokovým ohřivačem se použití uzávěru teplé vody nedoporučuje.



ROZMĚRY (viz strana 37)



DIAGRAM PRŮTOKU (viz strana 37)



① se zařízením EcoSmart®

② bez zařízení EcoSmart®

Servisní díly (viz strana 39)

XXX = Kód povrchové úpravy

000 = Chrom

020 = Polished Chrome

130 = Polished Bronze

140 = Brushed Bronze

250 = Brushed Gold-Optic

260 = Brushed Chrome

300 = Polished Redgold

310 = Brushed Redgold

330 = Polished Black Chrome

340 = Brushed Black Chrome

670 = Matt Black

800 = Nerezová Ocel

820 = Brushed Nickel

830 = Polished Nickel

930 = Polished Brass

950 = Brushed Brass

990 = Polished Gold-Optic

ZVLÁŠTNÍ PŘÍSLUŠENSTVÍ
(není součástí dodávky)



prodloužení 25 mm #13971000 (viz strana 39)



ČIŠTĚNÍ (viz strana 38)



OVLÁDÁNÍ (viz strana 40)

Hansgrohe doporučuje ráno nebo po delších přestávkách nepoužívat prvního půl litru jako pitnou vodu.



ZKUŠEBNÍ ZNAČKA (viz strana 39)

MONTÁŽ (viz strana 32)



△ BEZPEČNOSTNÉ POKYNY

- △ Pri montáži musíte nosiť rukavice, aby ste predišli pomliaždeninám a rezným poraneniam.
- △ Produkt sa smie používať len na kúpanie a telesnú hygienu.
- △ Veľké rozdiely v tlaku medzi prípojkami studenej a teplej vody musia byť vyrovnané.

POKYNY PRE MONTÁŽ

- / Pred montážou musíte produkt skontrolovať, či nebol počas transportu poškodený. Po zabudovaní nebudú uznané žiadne škody spôsobené transportom alebo poškodenia povrchu.
- / Potrubia a vybavenie musia byť namontované, prepláchnuté a vybavené v platnom normami.
- / Je potrebné dodržiavať smernice o inštalácii, ktoré sú práve teraz platné v krajinách.
- / Odtokový ventil sa smie používať iba na použitie v súlade s určením. Upevňovanie iných predmetov, napr. polovičného sfípu na odtokový ventil, nie je prípustné.
- / Pri problémoch s prietokovým ohrievačom alebo ak je požadovaný väčší prietok vody, môže sa demontovať zariadenie EcoSmart® (obmedzovač prietoku), ktoré je umiestnené za perlátorom.

TECHNICKÉ ÚDAJE

Armatura je sériovo vybavená zariadením EcoSmart® (obmedzovač prietoku)

Prevádzkový tlak: max. 1 MPa
 Doporučený prevádzkový tlak: 0,1 - 0,5 MPa
 Skúšobný tlak: 1,6 MPa
 (1 MPa = 10 bar = 147 PSI)

Teplota teplej vody: max. 60°C
 Termická dezinfekcia: 70°C/4 min

Výrobok je koncipovaný výhradne pre pitnú vodu!

POPIS SYMBOLOV

Nepoužívať silikón s obsahom kyseliny octovej!



NASTAVENIE (viď strana 36)

Nastavenie obmedzenia teplej vody. V spojení s prietokovými ohrievačmi sa neodporúča použitie obmedzovača teplej vody.



ROZMERY (viď strana 37)



DIAGRAM PRIETOKU
 (viď strana 37)



- ① so zariadením EcoSmart®
 - ② bez zariadenia EcoSmart®
- Servisné diely (viď strana 39)
- XXX = Farebné označenie
 000 = Chróm
 020 = Polished Chrome
 130 = Polished Bronze
 140 = Brushed Bronze
 250 = Brushed Gold-Optic
 260 = Brushed Chrome
 300 = Polished Redgold
 310 = Brushed Redgold
 330 = Polished Black Chrome
 340 = Brushed Black Chrome
 670 = Matt Black
 800 = Ušľachtilá Oceľ
 820 = Brushed Nickel
 830 = Polished Nickel
 930 = Polished Brass
 950 = Brushed Brass
 990 = Polished Gold-Optic

ZVLÁŠTNE PRÍSLUŠENSTVO
 (nie je súčasťou dodávky)



Prdlženie 25 mm #13971000 (viď strana 39)



ČISTENIE (viď strana 38)



OBSLUHA (viď strana 40)

Hansgrohe odporúča ráno a po dlhších dobách odstavky nepoužiť prvého pol litra vody ako pitnú vodu.



OSVEDČENIE O SKÚŠKE
 (viď strana 39)

MONTÁŽ (viď strana 32)



△ 安全技巧

- △ 装配时为避免挤压和切割受伤，必须戴上手套。
- △ 本产品只允许作为洗浴、卫生和洁身之用。
- △ 冷热水管间过大的压力差必须予以平衡。

安装提示

- / 安装前必须检查产品是否受到运输损害。安装后将不认可运输损害或表面损伤。
- / 管道和阀门必须根据通用标准进行安装、冲洗和检查。
- / 请遵守当地国家现行的安装规定。
- / 只能按规定使用溢流阀。禁止将半露柱及其他部件固定到溢流阀上。
- / 如果使用即热式热水器时出现问题，或要求更大的水流量，可以把位于水波器后面的 EcoSmart® (流量限制器) 拆除。

技术参数

本龙头配有 EcoSmart® (流量限制器)

工作压力: 最大 1 MPa

推荐工作压力: 0,1 - 0,5 MPa

测试压强: 1,6 MPa

(1 MPa = 10 bar = 147 PSI)

热水温度: 最大 60°C

热力消毒: 70°C / 4 分钟

该产品专为饮用水设计！

符号说明



请勿使用含有乙酸的硅胶！



调节 (参见第页 36)

热水温度调节。如果使用即热式喷头，则不建议安装热水阀门。



大小 (参见第页 37)



流量示意图 (参见第页 37)

① 带有 EcoSmart®

② 无 EcoSmart®

备用零件 (参见第页 39)

XXX = 颜色代码

000 = 镀铬

020 = Polished Chrome

130 = Polished Bronze

140 = Brushed Bronze

250 = Brushed Gold-Optic

260 = Brushed Chrome

300 = Polished Redgold

310 = Brushed Redgold

330 = Polished Black Chrome

340 = Brushed Black Chrome

670 = Matt Black

800 = 不锈钢表面

820 = Brushed Nickel

830 = Polished Nickel

930 = Polished Brass

950 = Brushed Brass

990 = Polished Gold-Optic

选装附件 (不在供货范围内)

加长件 25 mm #13971000 (参见第页 39)



清洗 (参见第页 38)



操作 (参见第页 40)



汉斯格雅建议，清晨或在水流长时间停滞
后，前半升水不作饮用水使用。



检验标记 (参见第页 39)

安装 (参见第页 32)



△ УКАЗАНИЯ ПО ТЕХНИКЕ БЕЗОПАСНОСТИ

- △ Во время монтажа следует надеть перчатки во избежание прищемления и порезов.
- △ Изделие разрешается использовать только в гигиенических целях: для принятия ванны и личной гигиены.
- △ донного клапа. Перед установкой смесителя необходимо регулировочными кранами выровнять давление холодной и горячей воды при помощи вентилей регулирующих подачу воды в квартиру.

УКАЗАНИЯ ПО МОНТАЖУ

- / Перед монтажом следует проверить изделие на предмет повреждений при перевозке. После монтажа претензии о возмещении ущерба за повреждения при перевозке или повреждения поверхностей не принимаются.
- / Трубы и арматура должны быть установлены, промыты и проверены в соответствии с действующими нормами.
- / Необходимо соблюдать требования по монтажу, действующие в соответствующих странах.
- / Спускной клапан разрешается использовать только в предусмотренных целях. На спускном клапане запрещается закреплять другие предметы, например, полуколонну.
- / Если возникнут проблемы с проточным бойлером или потребуется увеличить расход воды, то можно удалить EcoSmart® (ограничитель потока воды), который установлен за воздушным рассекателем.

ТЕХНИЧЕСКИЕ ДАННЫЕ

Смесители этой серии серийно оснащаются EcoSmart® (ограничителем потока воды)

Рабочее давление: не более. 1 МПа
 Рекомендуемое рабочее давление: 0,1 - 0,5 МПа
 Давление: 1,6 МПа
 (1 МПа = 10 bar = 147 PSI)

Температура горячей воды: не более. 60°C
 Термическая дезинфекция: 70°C/4 мин

Изделие предназначено исключительно для питьевой воды!

ОПИСАНИЕ СИМВОЛОВ



Не применяйте силикон, содержащий уксусную кислоту.



ПОДГОНКА (см. стр. 36)

Регулировка ограничителя горячей воды. В сочетании с проточными нагревателями не рекомендуется использовать блокировку воды.



РАЗМЕРЫ (см. стр. 37)



СХЕМА ПОТОКА (см. стр. 37)



① С EcoSmart®

② Без EcoSmart®

Комплект (см. стр. 39)

XXX = Цветная кодировка

000 = Хром

020 = Polished Chrome

130 = Polished Bronze

140 = Brushed Bronze

250 = Brushed Gold-Optic

260 = Brushed Chrome

300 = Polished Redgold

310 = Brushed Redgold

330 = Polished Black Chrome

340 = Brushed Black Chrome

670 = Matt Black

800 = Сталь

820 = Brushed Nickel

830 = Polished Nickel

930 = Polished Brass

950 = Brushed Brass

990 = Polished Gold-Optic

СПЕЦИАЛЬНЫЕ ПРИНАДЛЕЖНОСТИ (не включено в объем поставки!)

Удлинение 25 мм #13971000 (см. стр. 39)



ОЧИСТКА (см. стр. 38)



ЭКСПЛУАТАЦИЯ (см. стр. 40)



Hansgrohe рекомендует по утрам либо после длительного перерыва в использовании не использовать первые поллитра воды для питья.



ЗНАК ТЕХНИЧЕСКОГО КОНТРОЛЯ (см. стр. 39)

МОНТАЖ (см. стр. 32)



△ TURVALLISUUSOHJEET

- △ Asennuksessa on käytettävä käsineitä puristumien ja viiltojen aiheuttamien tapaturmien estämiseksi.
- △ Tuotetta saa käyttää ainoastaan kylpy-, hygienia- ja puhdistustarkoituksiin.
- △ Suuret paine-erot kylmä- ja kuumavesiliitäntöjen välillä on tasattava.

A SENNUSOHJEET

- / Ennen asennusta on tarkastettava tuotteen mahdolliset kuljetusvahingot. Asennuksen jälkeen kuljetus- ja pintavaurioita ei hyväksytä.
- / Putket ja hana on asennettava, huuhdeltava ja tarkastettava voimassa olevien standardien mukaisesti.
- / Jokaisessa maassa on noudatettava siellä päteviä asennusohjeita.
- / Poistoventtiiliä saa käyttää vain tarkoituksenmukaisesti. Poistoventtiiliin ei saa kiinnittää muita esineitä, esim. seinäkupua.
- / Jos läpivirtauskuumentimen kanssa on ongelmia tai jos halutaan suurempaa veden virtausmäärää, voidaan poreenmuodostajan takana oleva EcoSmart® (virtausrajoitin) poistaa.

TEKNISET TIEDOT

Kaluste on vakiona varustettu EcoSmart® (virtausrajoittimella)

Käyttöpaine:	maks. 1 MPa
Suosittelut käyttöpaine:	0,1 - 0,5 MPa
Koestuspaine:	1,6 MPa
	(1 MPa = 10 bar = 147 PSI)

Kuuman veden lämpötila:	maks. 60°C
Lämpödesinfektio:	70°C / 4 min

Tuote on suunniteltu käytettäväksi ainoastaan juomaveden kanssa!

MERKIN KUVAUS



Älä käytä etikkahappopitoista silikonia!



SÄÄTÖ (katso sivu 36)

Lämpötilan rajoittimen säätäminen. Emme suosittele käyttämään lämpötilan rajoitinta vedenlämmittimen (läpivirtauskuumentimen) yhteydessä.



MITAT (katso sivu 37)



VIRTAUSDIAGRAMMI
(katso sivu 37)



① sisältää EcoSmart®

② ilman EcoSmart®

Varaosat (katso sivu 39)

XXX = Värikoodaus

000 = Kromi

020 = Polished Chrome

130 = Polished Bronze

140 = Brushed Bronze

250 = Brushed Gold-Optic

260 = Brushed Chrome

300 = Polished Redgold

310 = Brushed Redgold

330 = Polished Black Chrome

340 = Brushed Black Chrome

670 = Matt Black

800 = Inox-Optinen

820 = Brushed Nickel

830 = Polished Nickel

930 = Polished Brass

950 = Brushed Brass

990 = Polished Gold-Optic

ERITYISVARUSTE (ei kuulu toimitukseen)



Pidennys 25 mm #13971000 (katso sivu 39)



PUHDISTUS (katso sivu 38)



KÄYTTÖ (katso sivu 40)

Hansgrohe suosittelee, että ensimmäistä puolta litraa ei käytetä juomavetenä aamuisin eikä silloin, kun laitetta ei ole käytetty pitkään aikaan.



KOESTUSMERKKI (katso sivu 39)

A SENNUS (katso sivu 32)



△ SÄKERHETSANVISNINGAR

- △ Handskar ska bäras under monteringsarbetet så att man kan undvika kläm- och skärskador.
- △ Produkten får bara användas till kroppshygien med bad och dusch.
- △ Stora tryckskillnader mellan anslutningarna för varmt och kallt vatten måste utjämnas.

MONTERINGSANVISNINGAR

- / Det måste undersökas om produkten har transportskador innan den monteras. Efter monteringen accepteras inga transport- eller ytskiktsskador.
- / Ledningarna och blandaren måste monteras, spolats igenom och kontrolleras enligt de gällande normerna.
- / De installationsriktlinjer som gäller i länderna ska följas.
- / Avrinningsventilen får bara användas till det som den är avsedd för. Det är inte tillåtet att montera andra föremål, t.ex. en kåpa, vid avrinningsventilen.
- / Om det är problem med vattenberedaren eller om större vattenflöde önskas kan EcoSmart® (flödeskontroll) som sitter bakom perlatorn tas bort.

TEKNISKA DATA

Blandare seriemässigt med EcoSmart® (flödeskontroll)

Driftstryck: max. 1 MPa

Rek. driftstryck: 0,1 - 0,5 MPa

Tryck vid provtryckning: 1,6 MPa

(1 MPa = 10 bar = 147 PSI)

Varmvattentemperatur: max. 60°C

Termisk desinfektion: 70°C/4 min

Produkten är enbart avsedd för dricksvatten!

SYMBOLFÖRKLARING



Använd inte silikon som innehåller ättiksyra!

 JUSTERING (se sidan 36)

Ställa in varmvattenregleringen. Tillsammans med varmvattenberedare rekommenderas inte en varmvattenspärr.

 MÅTTEN (se sidan 37)

 FLÖDESSCHEMA (se sidan 37)

① med EcoSmart®

② utan EcoSmart®

Reservdelar (se sidan 39)

XXX = Färgkodning

000 = Krom

MONTERING (se sidan 32)



020 = Polished Chrome
 130 = Polished Bronze
 140 = Brushed Bronze
 250 = Brushed Gold-Optic
 260 = Brushed Chrome
 300 = Polished Redgold
 310 = Brushed Redgold
 330 = Polished Black Chrome
 340 = Brushed Black Chrome
 670 = Matt Black
 800 = Rostfri-Optik
 820 = Brushed Nickel
 830 = Polished Nickel
 930 = Polished Brass
 950 = Brushed Brass
 990 = Polished Gold-Optic

SPECIALTILLBEHÖR
 (medföljer ej leveransen)

 Förlängning 25 mm #13971000 (se sidan 39)

 RENGÖRING (se sidan 38)

 HANTERING (se sidan 40)

Handgrohe rekommenderar att den första halvlitern inte används som dricksvatten på morgonen eller efter längre perioder utan användning.



TESTSIGILL (se sidan 39)

△ SAUGUMO TECHNIKOS NURODYMAI

- △ Apsaugai nuo užspaudimo ir įsijovimo montavimo metu mūvėkite pirštines.
- △ Gaminys turi būti naudojamas tik maudymuisi, kūno higienai ir švarai palaikyti.
- △ Turi būti išlyginti šalto ir karšto slėgio nelygumai.

MONTAVIMO INSTRUKCIJA

- / Prieš montuojant būtina patikrinti, ar gaminys nebuvo pažeistas transportavimo metu. Sumontavus pretenzijos dėl transportavimo ir paviršiaus pažeidimų nepriimamos.
- / Vamzdžiai ir sujungimai turi būti montuojami, plaunami ir tikrinami pagal galiojančias normas.
- / Laikykitės atitinkamoje šalyje galiojančių direktyvų dėl įrengimo.
- / Išleidimo vožtuvas gali būti naudojamas tik pagal savo paskirtį. Prie išleidimo vožtuvo draudžiama tvirtinti kitas dalis, pavyzdžiui, puskolones.
- / Jei yra problemų su momentiniu vandens šildytuvu ar neužtenka vandens srauto, galima pašalinti už aeratoriaus esantį „EcoSmart®“ (vandens srauto ribotuvą).

TECHNINIAI DUOMENYS

Šios serijos maišytuvai turi EcoSmart® (vandens srauto ribotuvą)

Darbinis slėgis: ne daugiau kaip 1 MPa
 Rekomenduojamas slėgis: 0,1 - 0,5 MPa
 Bandomasis slėgis: 1,6 MPa

(1 MPa = 10 barų = 147 PSI)

Karšto vandens temperatūra: ne daugiau kaip 60°C
 Terminis dezinfekavimas: 70°C / 4 min

Produktas skirtas tik geriamajam vandeniui!

SIMBOLIO APRAŠYMAS



Nenaudokite silikono, kurio sudėtyje yra acto rūgšties!



REGULIAVIMAS (žr. psl. 36)

Karšto vandens ribojimas. Kartu su cirkuliaciniais šildytuvais nerekomenduojama naudoti karšto vandens blokavimo įtaisų.



IŠMATAVIMAI (žr. psl. 37)



PRALAUDIMO DIAGRAMA (žr. psl. 37)

① su EcoSmart®

② be EcoSmart®



Atsarginės dalys (žr. psl. 39)

XXX = Spalvos

000 = Chrom

020 = Polished Chrome

130 = Polished Bronze

140 = Brushed Bronze

250 = Brushed Gold-Optic

260 = Brushed Chrome

300 = Polished Redgold

310 = Brushed Redgold

330 = Polished Black Chrome

340 = Brushed Black Chrome

670 = Matt Black

800 = Plienas

820 = Brushed Nickel

830 = Polished Nickel

930 = Polished Brass

950 = Brushed Brass

990 = Polished Gold-Optic

SPECIALŪS PRIEDAI (nėra pridedama)

Ilgiklis 25 mm #13971000 (žr. psl. 39)



VALYMAS (žr. psl. 38)

EKSPLOATACIJA (žr. psl. 40)

Naudojant po ilgesnės pertraukos, „Hansgrohe“ rekomenduoja pirmo pusės litro vandens nevirtoti kaip geriamojo.



BANDYMO PAŽYMA (žr. psl. 39)

MONTAVIMAS (žr. psl. 32)



△ SIGURNOSNE UPUTE

- △ Prilikom montaže se radi sprječavanja prignječenja i posjekotina moraju nositi rukavice.
- △ Proizvod se smije primjenjivati samo za kupanje, tuširanje i osobnu higijenu.
- △ Velika razlika u pritisku između vruće i hladne vode mora biti izbalansirana.

UPUTE ZA MONTAŽU

- / Prije montaže mora se provjeriti je li proizvod oštećen prilikom transporta. Nakon ugradnje se ne priznaju nikakve reklamacije koje se odnose na površinska i transportna oštećenja.
- / Cijevi i armatura moraju biti postavljeni, isprani i testirani prema važećim normama.
- / Obvezno se moraju uvažiti propisi o instalacijama koji vrijede u dotičnoj zemlji.
- / Odvodni ventil smije se koristiti samo namjenski. Pričvršćivanje drugih predmeta npr. polustubova na odvodnom ventilu nije dopušteno.
- / Ako dolazi do problema s protočnim bojlerom ili se želi veći protok vode, može se ukloniti EcoSmart® (limitator protoka) lociran iza aeratora.

TEHNIČKI PODATCI

Armatura ima serijski ugrađen EcoSmart® (limitator protoka)

Najveći dopušteni tlak:	tlak 1 MPa
Preporučeni tlak:	0,1 - 0,5 MPa
Probni tlak:	1,6 MPa

(1 MPa = 10 bar = 147 PSI)

Temperatura vruće vode: tlak 60°C

Termička dezinfekcija: 70°C / 4 min

Proizvod je koncipiran isključivo za pitku vodu!

OPIS SIMBOLA



Nemojte koristiti silikon koji sadrži octenu kiselinu!



REGULACIJA (pogledaj stranicu 36)

Namještanje limitera tople vode. U kombinaciji s protočnim bojlerima nije preporučljiva primjena sustava za blokiranje dotoka tople vode.



MJERE (pogledaj stranicu 37)



DIJAGRAM PROTOKA

(pogledaj stranicu 37)

① s limitatorom EcoSmart®

② bez limitatora EcoSmart®



Rezervni djelovi (pogledaj stranicu 39)

XXX = Boje

000 = Krom

020 = Polished Chrome

130 = Polished Bronze

140 = Brushed Bronze

250 = Brushed Gold-Optic

260 = Brushed Chrome

300 = Polished Redgold

310 = Brushed Redgold

330 = Polished Black Chrome

340 = Brushed Black Chrome

670 = Matt Black

800 = Plemeniti Čelik

820 = Brushed Nickel

830 = Polished Nickel

930 = Polished Brass

950 = Brushed Brass

990 = Polished Gold-Optic

POSEBNI PRIBOR

(Nije sadržano u isporuci!)



Produljenje 25 mm #13971000

(pogledaj stranicu 39)



ČIŠĆENJE (pogledaj stranicu 38)



UPOTREBA (pogledaj stranicu 40)

Hansgrohe preporuča da ujutro ili nakon duljeg nekoristenja prvih 1/2 litre vode ne upotrebljavate za piće.



OZNAKA TESTIRANJA

(pogledaj stranicu 39)

SASTAVLJANJE (pogledaj stranicu 32)



△ GÜVENLİK UYARILARI

- △ Montaj esnasında ezilme ve kesilme gibi yaralanmaları önlemek için eldiven kullanılmalıdır.
- △ Ürün yalnızca banyo, hijyen ve beden temizliği amaçları doğrultusunda kullanılabilir.
- △ Sıcak ve soğuk su bağlantıları arasında büyük basınç farklılıkları varsa, bu basınç farklılıklarının dengelenmesi gerekir.

MONTAJ AÇIKLAMALARI

- / Montaj işleminden önce ürün nakliye hasarları yönünden kontrol edilmelidir. Montaj işleminden sonra nakliye veya yüzey hasarları için sorumluluk üstlenilmemektedir.
- / Boruların ve armatürün montajı, yıkanması ve kontrolü geçerli normlara göre yapılmalıdır.
- / Ülkelerde geçerli kurulum yönetmeliklerine riayet edilmelidir.
- / Drenaj valfi sadece amacına uygun şekilde kullanılabilir. Yarı sütun gibi diğer nesnelerin drenaj valfi üzerine sabitlenmesine izin verilmez.
- / Sürekli akışlı su ısıtıcıları ile birlikte kullanımında problemler söz konusu ise veya akan su miktarının daha fazla olması isteniyorsa, perlatörün arka tarafındaki EcoSmart® (akış sınırlayıcısı) sökülüp çıkarılabilir.

TEKNİK BİLGİLER

Batarya EcoSmart® (akış sınırlayıcısı) ile birlikte seri olarak işletme basıncı: azami 1 MPa
 Tavsiye edilen işletme basıncı: 0,1 - 0,5 MPa
 Kontrol basıncı: 1,6 MPa
 (1 MPa = 10 bar = 147 PSI)

Sıcak su sıcaklığı: azami 60°C
 Termik dezenfeksiyon: 70°C/4 dak

Ürün sadece şebeke suyu için tasarlanmıştır!

SİMGE AÇIKLAMASI

 Asetik asit içeren silikon kullanmayın!

 AYARLAMA (bakınız sayfa 36)

Sıcak su sınırlamasının ayarlanması. Sıcak su kilidinin sürekli ısıtıcıyla kullanılması tavsiye edilmez.

 ÖLÇÜLERİ (bakınız sayfa 37)

MONTAJI (bakınız sayfa 32)



AKIŞ DİYAGRAMI (bakınız sayfa 37)

① EcoSmart® dahil

② EcoSmart® hariç



Yedek Parçalar (bakınız sayfa 39)

XXX = Renkler

000 = Krom

020 = Polished Chrome

130 = Polished Bronze

140 = Brushed Bronze

250 = Brushed Gold-Optic

260 = Brushed Chrome

300 = Polished Redgold

310 = Brushed Redgold

330 = Polished Black Chrome

340 = Brushed Black Chrome

670 = Matt Black

800 = Paslanmaz Çelik-Optik

820 = Brushed Nickel

830 = Polished Nickel

930 = Polished Brass

950 = Brushed Brass

990 = Polished Gold-Optic

ÖZEL AKSESUARLAR

(Teslimat kapsamına dahil değildir)

Uzatma 25 mm #13971000 (bakınız sayfa 39)



TEMİZLEME (bakınız sayfa 38)



KULLANIMI (bakınız sayfa 40)

Hansgrohe sabahları uzun durgunluk süresi sonrasında ilk yarım litre suyun içme suyu olarak kullanılmamasını önerir.



KONTROL İŞARETİ

(bakınız sayfa 39)

△ INSTRUCȚIUNI DE SIGURANȚĂ

- △ La montare utilizați mănuși pentru evitarea contuziunilor și tăierii mâinilor.
- △ Produsul poate fi utilizat doar pentru spălarea, menținerea igienei și curățarea corpului.
- △ Diferențele de presiune mari între alimentarea cu apă rece și apă caldă trebuie echilibrate.

INSTRUCȚIUNI DE MONTARE

- / Înainte de instalare verificați, dacă produsul prezintă deteriorări de transport. După instalare garanția nu acoperă deteriorările de transport și cele de suprafață.
- / Conductele și bateriile trebuie montate, spălate și verificate conform normelor în vigoare.
- / Respectați reglementările referitoare la instalare valabile în țara respectivă.
- / Supapa de scurgere poate fi utilizată doar conform destinației. Fixarea altor obiecte, de ex. a unui semi-stâlp la supapa de scurgere este interzisă.
- / Dacă apar probleme cu boilerul instant sau dacă doriți un debit de apă mai mare, puteți să demontați unitatea EcoSmart® (limitatorul de debit), care se află în spatele suflătorului de aer.

DATE TEHNICE

Bateria este dotată în serie cu EcoSmart® (limitator de debit)

Presiune de funcționare:	max. 1 MPa
Presiune de funcționare recomandată:	0,1 - 0,5 MPa
Presiune de verificare:	1,6 MPa
	(1 MPa = 10 bar = 147 PSI)
Temperatura apei calde:	max. 60°C
Dezinfecție termică:	70°C / 4 min
Produsul este destinat exclusiv pentru apă potabilă.	

DESCRIEREA SIMBOLURILOR



Nu utilizați silicon cu conținut de acid acetic!



REGLARE (vezi pag. 36)

Reglarea limitatorului de apă caldă. Nu se recomandă folosirea unui limitator de apă caldă în combinație cu un boiler instant.



DIMENSIUNI (vezi pag. 37)



DIAGRAMA DE DEBIT
(vezi pag. 37)

① cu EcoSmart®

② fără EcoSmart®



Piese de schimb (vezi pag. 39)

XXX = Coduri de culori

000 = Crom

020 = Polished Chrome

130 = Polished Bronze

140 = Brushed Bronze

250 = Brushed Gold-Optic

260 = Brushed Chrome

300 = Polished Redgold

310 = Brushed Redgold

330 = Polished Black Chrome

340 = Brushed Black Chrome

670 = Matt Black

800 = Otel Inox

820 = Brushed Nickel

830 = Polished Nickel

930 = Polished Brass

950 = Brushed Brass

990 = Polished Gold-Optic

ACCESORII OPȚIONALE

(nu este inclus în setul livrat)



Prelungitor 25 mm #13971000 (vezi pag. 39)



CURĂȚARE (vezi pag. 38)



UTILIZARE (vezi pag. 40)

Hansgrohe vă recomandă, ca dimineața sau după perioade mai lungi de pauză să nu folosiți prima jumătate de litru de apă pentru băut.



CERTIFICAT DE TESTARE
(vezi pag. 39)

MONTARE (vezi pag. 32)



ΔΥΠΟΔΕΙΞΕΙΣ ΑΣΦΑΛΕΙΑΣ

- ▲ Για να αποφύγετε τραυματισμούς κατά τη συναρμολόγηση πρέπει να φοράτε γάντια.
- ▲ Το προϊόν επιτρέπεται να χρησιμοποιείται μόνο σαν μέσο λουτρού, υγιεινής και καθαρισμού του σώματος.
- ▲ Οι διαφορές της πίεσης μεταξύ της σύνδεσης κρύου και ζεστού νερού θα πρέπει να αντισταθμίζονται.

ΟΔΗΓΙΕΣ ΣΥΝΑΡΜΟΛΟΓΗΣΗΣ

- / Πριν τη συναρμολόγηση πρέπει να εξεταστεί το προϊόν για ζημιές μεταφοράς. Μετά την εγκατάσταση δεν αναγνωρίζονται ζημιές από τη μεταφορά ή επιφανειακές ζημιές.
- / Οι σωλήνες και η μπαταρία πρέπει να τοποθετηθούν σύμφωνα με τα ισχύοντα πρότυπα, να τεθούν υπό πίεση και να δοκιμαστούν.
- / Θα πρέπει να τηρούνται οι οδηγίες εγκατάστασης που ισχύουν σε κάθε κράτος.
- / Η βαλβίδα εκροής επιτρέπεται να χρησιμοποιείται μόνο για την προβλεπόμενη χρήση. Η στερέωση άλλων αντικειμένων π.χ. μισής κολώνας στη βαλβίδα εκροής δεν επιτρέπεται.
- / Εάν παρουσιαστεί πρόβλημα με τον ταχυθερμοσίφωνα ή όταν απαιτείται περισσότερο νερό, μπορεί να απομακρυνθεί ο EcoSmart® (μειωτής ροής), ο οποίος βρίσκεται πίσω από το φίλτρο του ρουζουιού.

ΤΕΧΝΙΚΑ ΧΑΡΑΚΤΗΡΙΣΤΙΚΑ

Μπαταρία μόνιμα εξοπλισμένη με EcoSmart® (μειωτής ροής)

Λειτουργία πίεσης: έως 1 MPa
 Συνιστώμενη λειτουργία πίεσης: 0,1 - 0,5 MPa
 Πίεση ελέγχου: 1,6 MPa
 (1 MPa = 10 bar = 147 PSI)

Θερμοκρασία ζεστού νερού: έως 60°C
 Θερμική απολύμανση: 70°C / 4 min

Το προϊόν έχει σχεδιαστεί αποκλειστικά για πόσιμο νερό!

ΠΕΡΙΓΡΑΦΗ ΣΥΜΒΟΛΩΝ



Μην χρησιμοποιείτε σιλικόνη που περιέχει οξικό οξύ!



ΡΥΘΜΙΣΗ (βλ. Σελίδα 36)

Ρύθμιση του δοσομετρητή ζεστού νερού. Δεν συνιστάται η διάταξη φραγής ζεστού νερού σε συνδυασμό με ταχυθερμοσίφωνα.



ΔΙΑΣΤΑΣΕΙΣ (βλ. Σελίδα 37)

ΣΥΝΑΡΜΟΛΟΓΗΣΗ (βλ. Σελίδα 32)



ΔΙΑΓΡΑΜΜΑ ΡΟΗΣ (βλ. Σελίδα 37)



① με EcoSmart®

② χωρίς EcoSmart®

Ανταλλακτικά (βλ. Σελίδα 39)

XXX = Χρώματα

000 = Επιχρωμωμένο

020 = Polished Chrome

130 = Polished Bronze

140 = Brushed Bronze

250 = Brushed Gold-Optic

260 = Brushed Chrome

300 = Polished Redgold

310 = Brushed Redgold

330 = Polished Black Chrome

340 = Brushed Black Chrome

670 = Matt Black

800 = Οπτική Ανοξειδωτου Χάλυβα

820 = Brushed Nickel

830 = Polished Nickel

930 = Polished Brass

950 = Brushed Brass

990 = Polished Gold-Optic

ΕΙΔΙΚΑ ΑΞΕΣΟΥΡ (δεν περιλαμβάνεται στον παραδοτέο εξοπλισμό)



Σωλήνας επιμήκυνσης 25 mm #13971000
 (βλ. Σελίδα 39)



ΚΑΘΑΡΙΣΜΟΣ (βλ. Σελίδα 38)



ΧΕΙΡΙΣΜΟΣ (βλ. Σελίδα 40)

Η Hansgrohe συνιστά το πρωί ή μετά από μεγάλα χρονικά διαστήματα αχρησίας να μην χρησιμοποιείτε το πρώτο μισό λίτρο νερό σαν πόσιμο.



ΣΗΜΑ ΕΛΕΓΧΟΥ (βλ. Σελίδα 39)

△ VARNOSTNA OPOZORILA

- △ Pri montaži je treba nositi rokavice, da se preprečijo poškodbe zaradi zmečkanja ali urezov.
- △ Ta izdelek se sme uporabljati le z namenom umivanja, vzdrževanja higiene in telesne nege.
- △ Velike razlike v tlaku med priključkom za mrzlo in priključkom za toplo vodo je potrebno izravnati.

NAVODILA ZA MONTAŽO

- / Pred montažo je treba izdelek preveriti glede morebitnih transportnih poškodb. Po vgradnji transportne ali površinske poškodbe ne bodo več priznane.
- / Cevi in armaturo je treba montirati, izprati in preveriti po veljavnih standardih.
- / Upoštevati je treba pravilnike o inštalacijah, ki veljajo v posamezni državi.
- / Odtočni ventil se sme uporabljati le v skladu z namenom uporabe. Prilrditev drugih elementov na odtočni ventil, npr. polstebra, ni dovoljena.
- / Če imate probleme s pretočnim grelnikom, ali če želite večji pretok vode, lahko odstranite EcoSmart® (omejevalnik pretoka), ki se nahaja za perlatorjem.

TEHNIČNI PODATKI

Armaturo je serijsko opremljena z EcoSmart® (omejevalnikom pretoka)

Delovni tlak: maks. 1 MPa
 Priporočeni delovni tlak: 0,1 - 0,5 MPa
 Preskusni tlak: 1,6 MPa

(1 MPa = 10 bar = 147 PSI)

Temperatura tople vode: maks. 60°C
 Termična dezinfekcija: 70°C / 4 min

Proizvod je zasnovan izključno za sanitarno vodol!

OPIS SIMBOLA

Ne smete uporabiti silikona, ki vsebuje ocatno kislino!



JUSTIRANJE (glejte stran 36)

Nastavitev omejevalnika tople vode. V povezavi s pretočnimi grelniki uporaba zapore tople vode ni priporočljiva.



MERE (glejte stran 37)

**DIAGRAM PRETOKA**

(glejte stran 37)



- ① z omejevalnikom pretoka EcoSmart®
 - ② brez omejevalnika pretoka EcoSmart®
- Rezervni deli (glejte stran 39)

XXX = Barve
 000 = Krom
 020 = Polished Chrome
 130 = Polished Bronze
 140 = Brushed Bronze
 250 = Brushed Gold-Optic
 260 = Brushed Chrome
 300 = Polished Redgold
 310 = Brushed Redgold
 330 = Polished Black Chrome
 340 = Brushed Black Chrome
 670 = Matt Black
 800 = Videz Legiranega Jekla
 820 = Brushed Nickel
 830 = Polished Nickel
 930 = Polished Brass
 950 = Brushed Brass
 990 = Polished Gold-Optic

POSEBEN PRIBOR (Ni vključeno)

Podaljšek 25 mm #13971000 (glejte stran 39)



ČIŠČENJE (glejte stran 38)



UPRAVLJANJE (glejte stran 40)

Hansgrohe priporoča, da zjutraj ali po daljšem času stagnacije prvega pol litra vode ne uporabite kot pitno vodo.



PRESKUSNI ZNAK (glejte stran 39)

MONTAŽA (glejte stran 32)



△ OHUTUSJUHISED

- △ Kandke paigaldamisel muljumis- ja löikevigastuste vältimiseks kindaid.
- △ Toodet tohib kasutada ainult pesemis-, hügieeni- ja kehahapustamiseemärkidel.
- △ Kui külma ja kuuma vee ühenduste surve on väga erinev, tuleb need tasakaalustada.

PAIGALDAMISJUHISED

- / Enne paigaldamist tuleb toodet kontrollida transpordikahjustuste osas. Pärast paigaldamist ei tunnustata enam transpordi- või pinnakahjustuste kaebuseid.
- / Voolikute ja segisti paigaldamisel, loputamisel ja kontrollimisel tuleb lähtuda kehtivatest normatiividest.
- / Vastavas riigis kehtivaid paigalduseeskirju tuleb järgida.
- / Tühjenduskraani võib kasutada ainult ettenähtud viisil. Muude esemete, nt sifooni, kinnitamine tühjenduskraani külge ei ole lubatud.
- / Kui esineb probleeme läbivooluhooleiga või kui soovitakse, et vee läbivool oleks suurem, tuleks sõela taga asuv EcoSmart® (veehulgapiiraja) eemaldada.

TEHNILISED ANDMED

Segistisari on toodetud koos EcoSmart® (veehulgapiirajaga)

Töörõhk maks. 1 MPa
 Soovitatav töörõhk: 0,1 - 0,5 MPa
 Kontrollsurve: 1,6 MPa

(1 MPa = 10 baari = 147 PSI)

Kuuma vee temperatuur: maks. 60°C
 Termiline desinfektsioon: 70°C / 4 min

Toode on ette nähtud eranditult joogivee jaoks!

SÜMBOLITE KIRJELDUS



Ärge kasutage äädikhapet sisaldavat silikooni!



REGULEERIMINE (vt lk 36)

Sooja vee piirangu seadistamine. Ühenduses boileritega ei ole sooja vee blokeeringu soovitatav.



MÕÕTUDE (vt lk 37)



LÄBIVOOLUDIAGRAMM (vt lk 37)



① EcoSmart® olemas

② EcoSmart® puudub

Varuosad (vt lk 39)

XXX = Värv

000 = Kroom

020 = Polished Chrome

130 = Polished Bronze

140 = Brushed Bronze

250 = Brushed Gold-Optic

260 = Brushed Chrome

300 = Polished Redgold

310 = Brushed Redgold

330 = Polished Black Chrome

340 = Brushed Black Chrome

670 = Matt Black

800 = Roostevaba Optik

820 = Brushed Nickel

830 = Polished Nickel

930 = Polished Brass

950 = Brushed Brass

990 = Polished Gold-Optic

SPETSIAALNE LISAVARUSTUS

(ei sisaldu komplektis)



Pikendus 25 mm #13971000 (vt lk 39)



PUHASTAMINE (vt lk 38)



KASUTAMINE (vt lk 40)

Hansgrohe soovib mitte kasutada esimest poolt liitrit hommikuti või pärast pikemat seisakuaega joogiveena.



KONTROLLSERTIFIKAAT (vt lk 39)

PAIGALDAMINE (vt lk 32)



△ DROŠĪBAS NORĀDES

- △ Montāžas laikā, lai izvairītos no saspiedumiem un iegriezumiem, nepieciešams nēsāt cimdus.
- △ Šo produktu drīkst izmantot tikai, lai mazgātos, higiēnai un ķermeņa tīrīšanai.
- △ Jāizlīdzina spiediena atšķirības starp aukstā un karstā ūdens pievadiem.

NORĀDĪJUMI MONTĀŽAI

- / Pirms montāžas nepieciešams pārbaudīt, vai produktam transportēšanas laikā nav radušies bojājumi. Pēc iebūvēšanas bojājumi, kas radušies transportēšanas laikā, vai virsmas bojājumi netiek atzīti.
- / Caurulvadi un armatūra ir jāuzstāda, jāizskalo un jāpārbauda saskaņā ar spēkā esošajiem standartiem.
- / Jāievēro attiecīgās valsts spēkā esošās montāžas prasības.
- / Noteces vārstu drīkst izmantot tikai noteiktajam mērķim. Pie noteces vārsta aizliegts piestiprināt citus priekšmetus, piemēram, puskolonnus.
- / Ja rodas problēmas ar caurteces sildītāju vai ja ūdens plūsma nav pietiekami spēcīga, EcoSmart® (caurteces ierobežotāju), kas atrodas aiz aeratora, drīkst noņemt.

TEHNISKIE DATI

Jaucējkrāns tiek ražots kopā ar EcoSmart® (caurteces ierobežotāju)

Darba spiediens:	maks. 1 MPa
Ieteicamais darba spiediens:	0,1 - 0,5 MPa
Pārbaudes spiediens:	1,6 MPa
	(1 MPa = 10 bar = 147 PSI)

Karstā ūdens temperatūra:	maks. 60°C
Termiskā dezinfekcija:	70°C / 4 min

Izstrādājums ir paredzēts tikai dzeramajam ūdenim!

SIMBOLU NOZĪME



Neizmantot silikonu, kas satur etiķskābi!



IEREGULĒŠANA (skat. lpp. 36)

Karsta ūdens ierobežotāja regulēšana. Kopā ar caurteces sildītājiem nav ieteicams izmantot ūdens bloķētāju.



IZMĒRUS (skat. lpp. 37)



CAURPLŪDES DIAGRAMMA

(skat. lpp. 37)

① ar EcoSmart®

② bez EcoSmart®



Rezerves daļas (skat. lpp. 39)

XXX = Krāsu kodi

000 = Hroma

020 = Polished Chrome

130 = Polished Bronze

140 = Brushed Bronze

250 = Brushed Gold-Optic

260 = Brushed Chrome

300 = Polished Redgold

310 = Brushed Redgold

330 = Polished Black Chrome

340 = Brushed Black Chrome

670 = Matt Black

800 = Tērauda

820 = Brushed Nickel

830 = Polished Nickel

930 = Polished Brass

950 = Brushed Brass

990 = Polished Gold-Optic

SPECIĀLI AKSESUĀRI

(komplektā netiek piegādāts)



Pagarinājums 25 mm #13971000 (skat. lpp. 39)



TĪRĪŠANA (skat. lpp. 38)



LĪETOŠANA (skat. lpp. 40)

Hansgrohe iesaka no rīta vai pēc ilgākiem pārtraukumiem nelietot pirmo puslitru ūdens dzeršanai.



PĀRBAUDES ZĪME (skat. lpp. 39)

MONTĀŽA (skat. lpp. 32)



△ SIGURNOSNE NAPOMENE

- △ Prilikom montaže se radi sprečavanja prignječenja i posekotina moraju nositi rukavice.
- △ Proizvod sme da se koristi samo za kupanje, tuširanje i ličnu higijenu.
- △ Velika razlika u pritisku između vruće i hladne vode mora biti izbalansirana.

INSTRUKCIJE ZA MONTAŽU

- / Pre montaže se mora proveriti da li je proizvod oštećen pri transportu. Nakon ugradnje se ne priznaju nikakve reklamacije koje se odnose na površinska i transportna oštećenja.
- / Vodovi i armatura moraju biti postavljeni, isprani i testirani prema važećim normama.
- / Treba se pridržavati propisa koji u određenim zemljama važe za instalacije.
- / Odvodni ventil sme da se koristi samo namenski. Pričvršćivanje drugih predmeta npr. polustubova na odvodnom ventilu nije dozvoljeno.
- / Ukoliko se pojave problemi sa protočnim bojlerom ili se želi veći protok vode, onda EcoSmart® (ograničavač protoka vode), koji je smešten iza aeratora, može da se ukloni.

TEHNIČKI PODACI

Ove armature imaju serijski ugrađen EcoSmart® (ograničavač protoka vode)

Radni pritisak:	maks. 1 MPa
Preporučeni radni pritisak:	0,1 - 0,5 MPa
Probni pritisak:	1,6 MPa
	(1 MPa = 10 bar = 147 PSI)
Temperatura vruće vode:	maks. 60°C
Termička dezinfekcija:	70°C / 4 min

Proizvod je koncipiran isključivo za pijaću vodu!

OPIS SIMBOLA



Nemojte koristiti silikon koji sadrži sircetnu kiselinu!



PODEŠAVANJE (vidi stranu 36)

Podešavanje ograničivača tople vode. U kombinaciji sa protočnim bojlerima ne preporučuje se primena sistema za blokiranje dotoka tople vode.



MERE (vidi stranu 37)



DIJAGRAM PROTOKA
(vidi stranu 37)



① sa ograničivačem EcoSmart®
② bez ograničivača EcoSmart®
Rezervni delovi (vidi stranu 39)

XXX = Oznake boja
000 = Hrom
020 = Polished Chrome
130 = Polished Bronze
140 = Brushed Bronze
250 = Brushed Gold-Optic
260 = Brushed Chrome
300 = Polished Redgold
310 = Brushed Redgold
330 = Polished Black Chrome
340 = Brushed Black Chrome
670 = Matt Black
800 = Dezen Plemeniti Čelik
820 = Brushed Nickel
830 = Polished Nickel
930 = Polished Brass
950 = Brushed Brass
990 = Polished Gold-Optic

POSEBAN PRIBOR
(Nije sadržano u isporuci)



Produžetak 25 mm #13971000 (vidi stranu 39)



ČIŠĆENJE (vidi stranu 38)



RUKOVANJE (vidi stranu 40)

Hansgrohe preporučuje da ujutru ili nakon dužeg nekorišćenja prvih pola litre vode ne koristite za piće.



ISPITNI ZNAK (vidi stranu 39)

MONTAŽA (vidi stranu 32)



△ SIKKERHETSHENVISNINGER

- △ Bruk hansker under montasjen for å unngå klem- og kuttskader.
- △ Produktet skal kun brukes for bade-, hygiene- og kroppshygiene.
- △ Store trykkdifferanser mellom kaldt- og varmtvannstilkoblinger skal utlignes.

MONTAGEHENVISNINGER

- / Før montasjen skal produktet sjekkes for transportskader. Etter monteringen aksepteres ikke noen transport- eller overflateskader.
- / Ledningene og armaturen skal monteres, spyles og sjekkes iht. de gyldige normer.
- / Gjeldende retningslinjer for rørleggerarbeid i de enkelte land skal følges.
- / Utløpsventilen skal kun brukes på forskriftsmessig måte. Feste av andre gjenstander, som f.eks. en halvsøyle, til utløpsventilen er ikke tillatt.
- / Ved problemer med gjennomstrømningsvarmer, eller når man ønsker en større vanngjennomstrømning, kan EcoSmart® (gjennomstrømningsbegrensere) fjernes. Den sitter bak luftdysene.

TEKNISKE DATA

Armatyr er standardmessig utstyrt med EcoSmart® (gjennomstrømningsbegrensere)

Driftstrykk	maks. 1 MPa
Anbefalt driftstrykk:	0,1 - 0,5 MPa
Prøvetrykk	1,6 MPa
	(1 MPa = 10 bar = 147 PSI)

Varmtvannstemperatur maks. 60°C

Termisk desinfisering: 70°C/4 min

Produktet er utelukkende designet for drikkevann!

SYMBOLBESKRIVELSE

Ikke bruk silikon som inneholder eddiksyre!



J U S T E R I N G (se side 36)

Innstilling av varmtvannsbegrensning. I forbindelse med gjennomstrømningsvarmere er det ikke anbefalt å bruke en varmtvannssperre.



M Å L (se side 37)



GJENNOMSTRØMNINGSDIAGRAM (se side 37)

Ⓞ med EcoSmart®

Ⓢ uten EcoSmart®



Service-deler (se side 39)

XXX = Fargekode

000 = Krom

020 = Polished Chrome

130 = Polished Bronze

140 = Brushed Bronze

250 = Brushed Gold-Optic

260 = Brushed Chrome

300 = Polished Redgold

310 = Brushed Redgold

330 = Polished Black Chrome

340 = Brushed Black Chrome

670 = Matt Black

800 = Rustfritt Stål Optikk

820 = Brushed Nickel

830 = Polished Nickel

930 = Polished Brass

950 = Brushed Brass

990 = Polished Gold-Optic

EKSTRATILBEHØR

(ikke med i leveransen)



Forlengelse 25 mm #13971000 (se side 39)



R E N G J Ø R I N G (se side 38)



B E T J E N I N G (se side 40)

Om morgen og etter lengre stagnasjonstider anbefaler Hansgrohe å ikke bruke den første halvliteren som drikkevann.



P R Ø V E M E R K E (se side 39)

M O N T A S J E (se side 32)



△ УКАЗАНИЯ ЗА БЕЗОПАСНОСТ

- △ При монтажа трябва да се носят ръкавици, за да се избегнат наранявания поради притискане или порязване.
- △ Позволено е използването на продукта само за къпане, хигиена и цели на почистване на тялото.
- △ Големите разлики в налягането между изводите за студената и топлата вода трябва да се изравняват.

УКАЗАНИЯ ЗА МОНТАЖ

- / Преди монтажа продуктът трябва да се провери за транспортни щети. След монтажа не се признават транспортни или повърхностни щети.
- / Тръбопроводите и арматурата трябва да се монтира, промият и проверят в съответствие с валидните норми.
- / Трябва да бъдат спазвани валидните в съответните страни предписания за инсталиране.
- / Използването на клапана за отвеждане е позволено само по предназначение. Не е допустимо закрепването на други предмети, напр. на полуколона към клапана за отвеждане.
- / При проблеми с проточния нагревател или когато желаете по-голяма пропускателна способност на водата, може да отстраните EcoSmart® (ограничителя на протичане), който се намира зад аератора.

ТЕХНИЧЕСКИ ДАННИ

Арматурата е оборудвана серийно с EcoSmart® (ограничител на протичане)

Работно налягане:	макс. 1 МПа
Препоръчително работно налягане:	0,1 - 0,5 МПа
Контролно налягане:	1,6 МПа
	(1 МПа = 10 bar = 147 PSI)

Температура на горещата вода: макс. 60°C
Термична дезинфекция: 70°C/4 мин

Продуктът е разработен само за питейна вода!

ОПИСАНИЕ НА СИМВОЛИТЕ



Не използвайте силикон, съдържащ оцетна киселина!



ЮСТИРАНЕ (вижте стр. 36)

Настройка на ограничителя за топлата вода. Във връзка с проточни нагреватели не се препоръчва блокировка за топлата вода



РАЗМЕРИ (вижте стр. 37)

МОНТАЖ (вижте стр. 32)



ДИАГРАМА НА ПОТОКА (вижте стр. 37)

- ① с EcoSmart®
- ② без EcoSmart®



Сервизни части (вижте стр. 39)

XXX = Цветово кодиране
000 = Хром
020 = Polished Chrome
130 = Polished Bronze
140 = Brushed Bronze
250 = Brushed Gold-Optic
260 = Brushed Chrome
300 = Polished Redgold
310 = Brushed Redgold
330 = Polished Black Chrome
340 = Brushed Black Chrome
670 = Matt Black
800 = Оптика На Благородна Стомана
820 = Brushed Nickel
830 = Polished Nickel
930 = Polished Brass
950 = Brushed Brass
990 = Polished Gold-Optic

СПЕЦИАЛНИ ПРИНАДЛЕЖНОСТИ (не се съдържа в обема на доставка)

Удължител 25 мм #13971000 (вижте стр. 39)



ПОЧИСТВАНЕ (вижте стр. 38)



ОБСЛУЖВАНЕ (вижте стр. 40)

Hansgrohe препоръчва, сутрин и след по-продължително спиране първият половин литър да не се използва като питейна вода.



КОНТРОЛЕН ЗНАК (вижте стр. 39)

△ UDHËZIME SIGURIE

- △ Për të evituar lëndimet e pickimeve ose të prerjeve gjatë procesit të montimit duhet që të vishni doreza.
- △ Produkti duhet të përdoret vetëm qëllimet e banjave, të higjienës dhe të larjes së trupit.
- △ Ndryshimet e mëdha të presionit mes lidhjeve të ujit të ftohtë dhe atij të ngrohtë duhen ekuilibruar.

UDHËZIME PËR MONTIMIN

- / Përpara montimit duhet që produkti të kontrollohet për dëmtime nga transporti. Pas instalimit nuk do të njihet asnjë dëmtim nga transporti ose dëmtim i sipërfaqes.
- / Tubacionet dhe rubinetet duhet që të montohen, të shpëlahen dhe të kontrollohen sipas standardeve në fuqi
- / Duhet të respektohen linjat udhëzuese të instalimit, të vlefshme për vendet respektive.
- / Ventilii dalës mund të përdoret vetëm për përcaktimin teknik të përdorimit të tij. Nuk lejohet përforsimi apo vendosja e objekteve të tjera në ventilin dalës si p.sh. të një gjysëm harku.
- / Nëse lindin probleme me ngrohësin e ujit ose nëse dëshironi të keni më shumë qarkullim uji, atëherë EcoSmart® (kufizuesi i qarkullimit të ujit), i cili ndodhet pas ajrosësit, mund të çmontohet.

TË DHËNA TEKNIKE

Rubineti është i pajisur si standard me EcoSmart® (Kufizues qarkullimi)

Presioni gjatë punës	maks. 1 MPa
Presioni i rekomanduar:	0,1 - 0,5 MPa
Presioni për provë:	1,6 MPa
	(1 MPa = 10 bar = 147 PSI)
Temperatura e ujit të ngrohtë	maks. 60°C
Dezinfektim Termik:	70°C / 4 min

Produkti është projektuar ekskluzivisht për ujë të pijshëm!

PËRSHKRIMI I SIMBOLIT



Mos përdorni silikon që në përbërje ka acid acetik.



JUSTIMI (shih faqen 36)

Regullimi i kufizimit me ujë të nxehtë. Nje kombinim me një bojler ujit nuk është i rekomanduar.



PËRMASAT (shih faqen 37)



DIAGRAMI I QARKULLIMIT
(shih faqen 37)

① me EcoSmart®

② pa EcoSmart®



Pjesët e servisit (shih faqen 39)

XXX = Kodimi me anë të ngjyrave

000 = Krom

020 = Polished Chrome

130 = Polished Bronze

140 = Brushed Bronze

250 = Brushed Gold-Optic

260 = Brushed Chrome

300 = Polished Redgold

310 = Brushed Redgold

330 = Polished Black Chrome

340 = Brushed Black Chrome

670 = Matt Black

800 = Optikë Çeliku

820 = Brushed Nickel

830 = Polished Nickel

930 = Polished Brass

950 = Brushed Brass

990 = Polished Gold-Optic

PAJISJE TË POSAÇME

(nuk përfshihet në vëllimin e furnizimit)



Zgjatës 25 mm #13971000 (shih faqen 39)



PASTRIMI (shih faqen 38)



PËRDORIMI (shih faqen 40)

Hansgrohe rekomandon që në mëngjes ose pas periudhave të gjata që gjysmë litri i parë mos të pihet



SHENJA E KONTROLLIT
(shih faqen 39)

MONTIMI (shih faqen 32)



رسم للصراف (راجع صفحة 37)



① → EcoSmart
 ② بدون EcoSmart

قطع الغيار (راجع صفحة 39)
 الألوان = XXX
 كروم = 000
 Polished Chrome = 020
 Polished Bronze = 130
 Brushed Bronze = 140
 Brushed Gold-Optic = 250
 Brushed Chrome = 260
 Polished Redgold = 300
 Brushed Redgold = 310
 Polished Black Chrome = 330
 Brushed Black Chrome = 340
 Matt Black = 670
 مظهر الإستنليس ستيل = 800
 Brushed Nickel = 820
 Polished Nickel = 830
 Polished Brass = 930
 Brushed Brass = 950
 Polished Gold-Optic = 990

ملحقات خاصة

(غير مدرج مع المحتويات المسلمة)

وصلة إطالة 25 مم #13971000
 (راجع صفحة 39)



التنظيف (راجع صفحة 38)



التشغيل (راجع صفحة 40)



تتصح شركة هانز جروهي Hansgrohe بعدم استخدام أول نصف لتر من الماء لغرض الشرب وذلك في الصباح أو بعد توقف استخدام الماء لفترات طويلة نسبياً.

شهادة اختبار (راجع صفحة 39)



⚠ تنبيهات الأمان

⚠ يجب إرتداء قفازات اللبد أثناء التركيب لتجنب حدوث أخطار الإنحشار أو الجروح

⚠ لا يجب استخدام المنتج إلا في أغراض الاستحمام والأغراض الصحية وأغراض تنظيف الجسم.

⚠ يجب أن يكون تيار الماء الساخن والماء البارد متعادلين في الضغط.

تعليمات التركيب

/ قبل القيام بعملية التركيب، يجب فحص المنتج للتأكد من خلوه من أية تلفيات ناتجة عن النقل بعد القيام بعملية التركيب، لن يتم الاعتراف بوجود أية تلفيات سطحية أو تلفيات ناتجة عن عملية النقل.

/ يجب تركيب وغسيل واختبار التوصيلات وخلطات المياه طبقاً للمعايير السارية.

/ يجب مراعاة القواعد الخاصة بالتركيب وأعمال السباكة وفقاً للوائح الخاصة بكل بلد.

/ يجب استخدام صمام الصرف للأغراض المحددة فقط غير مسموح بتثبيت أشياء أخرى على صمام الصرف - على سبيل المثال نصف عامود.

/ إذا تسبب سخان الماء الجاري في أية مشكلات أو في حالة الرغبة في وجود تدفق أكثر للماء، يجب فك EcoSmart® (محدد تدفق المياه) الموجود خلف تجهيزة التهوية.

المواصفات الفنية

يتم بشكل قياسي إنتاج الخلاط هذا مع EcoSmart® (محدد تدفق المياه)

ضغظ التشغيل: الحد الأقصى 1 ميجابسكال

ضغظ التشغيل الموصى به: 0,1 - 0,5 ميجابسكال

ضغظ الاختبار: 1,6 ميجابسكال

(1 ميجابسكال = 10 بار = 147 PSI)

درجة حرارة الماء الساخن: الحد الأقصى 60°C

تعقيم حراري: 4 / 70°C الدقيقة

المنتج مخصص فقط لماء الشرب!

وصف الرمز

هام! لا تستخدم السليكون الذي يحتوي على أحماض!



الضبط (راجع صفحة 36)



ضبط تحديد المياه الدافئة. لا ينصح باستخدام محدد المياه الدافئة مع سخان المياه الوتقي.

أبعاد (راجع صفحة 37)



التركيب (راجع صفحة 32)

△ BIZTONSÁGI UTASÍTÁSOK

- △ A szerelésnél a zúzódások és vágási sérülések elkerülése érdekében kesztyűt kell viselni.
- △ A terméket csak fürdéshez, mosakodáshoz, és egészségügyi tisztálkodáshoz szabad használni.
- △ A hidegvíz- és a melegvíz-csatlakozások közötti nagy nyomáskülönbséget kikell egyenlíteni!

SZERELÉSI UTASÍTÁSOK

- / A szerelés előtt ellenőrizni kell, hogy a terméknek nincs-e szállítási sérülése. Beépítés után a szállítási-vagy felületi sérüléseket nem ismerik el.
- / A vezetékeket és a csaptelepet az érvényes szabványoknak megfelelően kell felszerelni, öblíteni és ellenőrizni
- / Az egyes országokban érvényes installációs irányelveket be kell tartani.
- / A lefolyószelepet csak rendeltetésszerűen szabad használni. Más tárgyak, pl. mosdólab, rögzítése a lefolyószelephez nem megengedett.
- / Ha problémák adódnak az átfolyós vízmelegítővel vagy nagyobb átfolyó vízmennyiségre van szükség, akkor az EcoSmart® (átfolyáskorlátozó) eltávolítható a perlátor mögül.

MŰSZAKI ADATOK

A csaptelep szeriakitvelben el van látva EcoSmart® (átfolyáskorlátozó) berendezéssel

Üzemi nyomás:	max. 1 MPa
Ajánlott üzemi nyomás:	0,1 - 0,5 MPa
Nyomáspróba:	1,6 MPa
	(1 MPa = 10 bar = 147 PSI)
Forróvíz hőmérséklet:	max. 60°C
Termikus fertőtlenítés:	70°C / 4 perc

A terméket kizárólag ivóvízhez tervezték!

SZIMBÓLUMOK LEÍRÁSA



Ne használjon ecetsavtartalmú szilikon!



BEÁLLÍTÁS (lásd az oldalon 36)

A meleg víz korlátozás beállítása. Átfolyós vízmelegítőknél meleg víz korlátozó használata nem ajánlott.



MÉRETET (lásd az oldalon 37)



ÁTFOLYÁSI DIAGRAMM (lásd az oldalon 37)

- ① EcoSmart® berendezéssel
 - ② EcoSmart® nélkül
- Tartozékok (lásd az oldalon 39)
- XXX = Szinkódolás
000 = Króm
020 = Polished Chrome
130 = Polished Bronze

SZERELÉS (lásd az oldalon 32)



140 = Brushed Bronze
250 = Brushed Gold-Optic
260 = Brushed Chrome
300 = Polished Redgold
310 = Brushed Redgold
330 = Polished Black Chrome
340 = Brushed Black Chrome
670 = Matt Black
800 = Acéloptika
820 = Brushed Nickel
830 = Polished Nickel
930 = Polished Brass
950 = Brushed Brass
990 = Polished Gold-Optic

EGYÉB TARTOZÉK

(a szállítási egység nem tartalmazza)



Hosszabbítás 25 mm #13971000 (lásd az oldalon 39)



TISZTÍTÁS (lásd az oldalon 38)



HASZNÁLAT (lásd az oldalon 40)

- / A csaptelepeken átfolyt víz hőmérséklete fogyasztásra szánt víz esetében a 65°C-ot nem haladhatja meg. A csaptelep nem eredményezheti az emberi fogyasztásra (pl. ivás és főzés céljából) szánt víz minőségromlását.
- / Beüzemelés és üzemszünetek után szigorúan be kell tartani a használati útmutatóban leírtakat. Beüzemelőkor a csaptelepet át kell öblíteni, legalább 2 percig történő hideg- és melegvízes folyamatot javasunk. Minimum 1 napos üzemszünet után fogyasztás előtt a csaptelepben stagnáló hideg- illetve melegvíz fogyasztása nem javasolt, a csaptelepben stagnáló vizet ki kell engedni, legalább 2 perces folytatás javasolt. A kifolytatás során nyert vizet ivóvízként, illetve ételkészítési céllal felhasználni nem szabad.
- / Tekintettel arra, hogy a forró víz fémoldó képessége a hideg víznél nagyobb, emiatt főzés és ivás céljából az OKI a hideg víz használatát javasolja.
- / A csaptelepek perlátorát javasolt havonta vízköteleníteni, illetve fertőtleníteni. A csaptelepek tisztítása, fertőtlenítése során kizárólag olyan vegyszer alkalmazható, amely megfelel a 201/2001. (X.25) Kormányrendelet, illetve a 38/2003. (VII.7) ÉSZCSM-FVM-KVVM együttes rendeletben leírtaknak.
- / A perlátor működési elvéből adódóan jelentős aeroszolt képez, így Legionella expozíció szempontjából fokozott kockázatot jelent. Ezért alkalmazása nem javasolt az egészségügyi intézmények fekvőbeteg ellátó szobáiban, illetve minden olyan helyen, ahol a hideg és/vagy használati melegvíz Legionella csíraszama eléri a 49/2015 (XI.6.) EMMI rendelet alapján meghatározott beavatkozási szintet.



VIZSGAJEL (lásd az oldalon 39)

△ 安全上の注意

- △ 施工の際は手を挟んだり怪我をしないように、手袋をはめてください。
- △ この製品は、体や手を洗う等の製品本来の目的以外には使用しないでください。
- △ 給水・湯の圧力差は0.1(MPa)以内としてください。

施工上の注意

- ／ 製品の施工前に輸送でのダメージがないか確認してください。施工後のキズ等のお申し出はお断りさせて頂いています。
- ／ 配管と水栓は、関連法規に従って施工、洗浄、および試験を行ってください。
- ／ 施工行う地域に適用される関連法規をお守りください。
- ／ 排水栓は、本来の使用目的以外に使用しないでください。その他の部品、例えば排水管カバー(semi-pedestal)等を直接取付けしないでください。
- ／ 流量が少なく給湯機の着火に問題がある場合や、流量を増やしたいときは、エアレーターの後ろにあるEcoSmart®(流量リミッター)を取り外すことができます。

技術資料

EcoSmart®(流量リミッター) 付きの水栓

使用圧力:	最大 1 MPa
推奨使用水压:	0,1 - 0,5 MPa
耐圧試験圧力:	1,6 MPa
	(1 MPa = 10 bar = 147 PSI)
給湯温度:	最大 60°C
お湯による高温消毒:	70°C / 4 分

この製品は飲料水での使用が前提となっています(日本においては水道法に適合する飲料水)!

アイコンの説明

 酢酸系シリコンをご使用にならないでください!



調整 (次のページを参照 36)

お湯の流量制限の設定方法。瞬間湯沸かし器をご利用の際はお湯の流量制限はしないでください。



寸法 (次のページを参照 37)

流量曲線図 (次のページを参照 37)



- ① エコスマート (EcoSmart®) 機能付き
- ② EcoSmart®機能なし



スペアパーツ (次のページを参照 39)

XXX = 仕上げ色

- 000 = Chrome
- 020 = Polished Chrome
- 130 = Polished Bronze
- 140 = Brushed Bronze
- 250 = Brushed Gold-Optic
- 260 = Brushed Chrome
- 300 = Polished Redgold
- 310 = Brushed Redgold
- 330 = Polished Black Chrome
- 340 = Brushed Black Chrome
- 670 = Matt Black
- 800 = Stainless Steel Optic
- 820 = Brushed Nickel
- 830 = Polished Nickel
- 930 = Polished Brass
- 950 = Brushed Brass
- 990 = Polished Gold-Optic

スペシャルパーツ (別手配部品)



延長部材 25 mm #13971000
(次のページを参照 39)



お手入れ方法 (次のページを参照 38)



使用方法 (次のページを参照 40)

ハンスグローエは、朝または長い間使用されなかった後に吐水する最初の0.5リットルは飲料水として使用しないことをお勧めします。



認証について (次のページを参照 39)

施工方法 (次のページを参照 32)



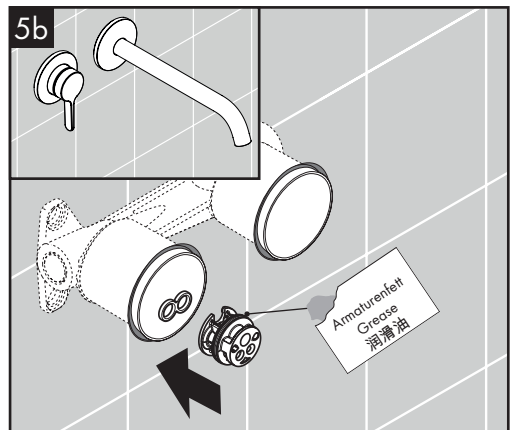
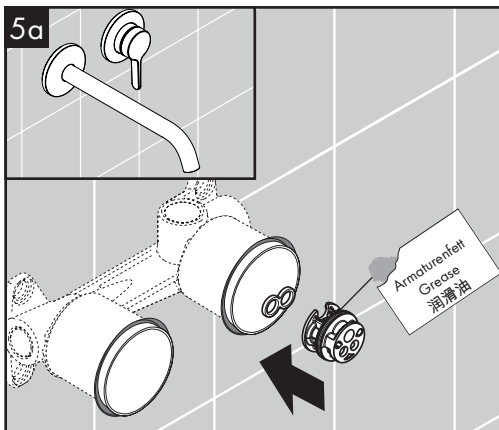
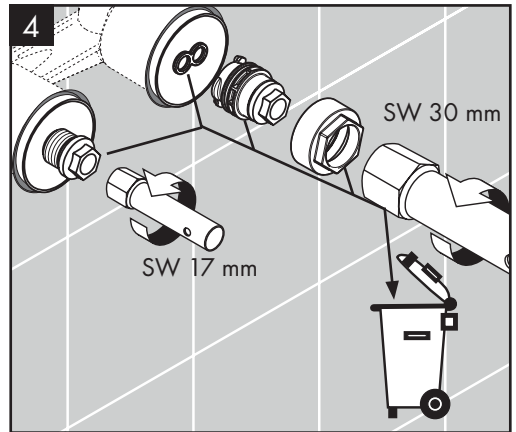
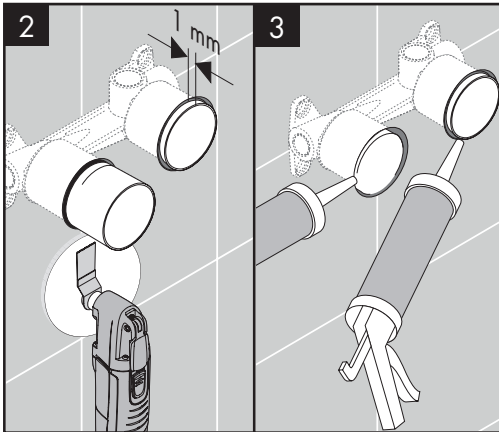
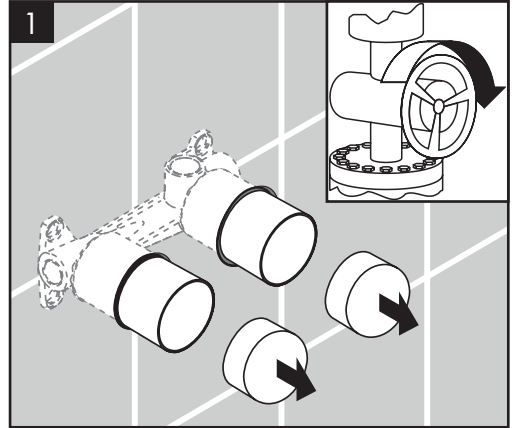
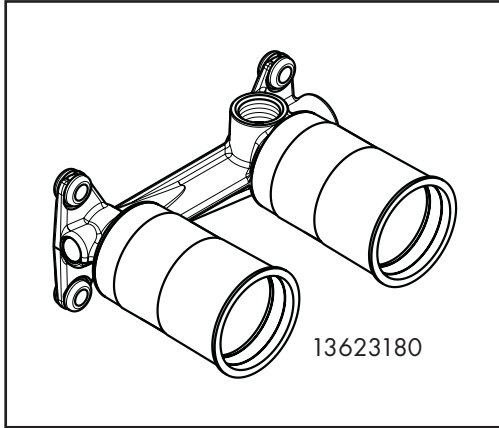

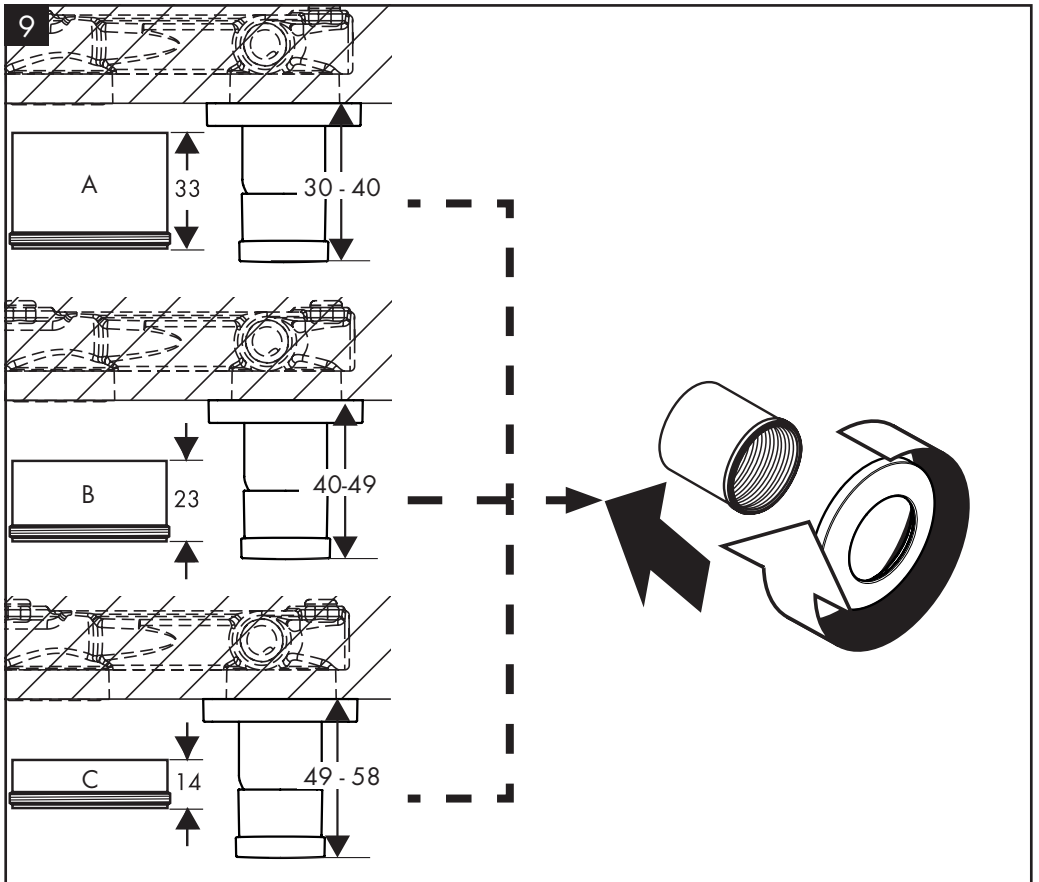
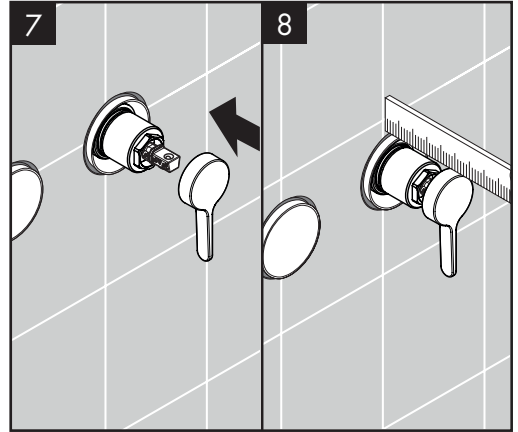
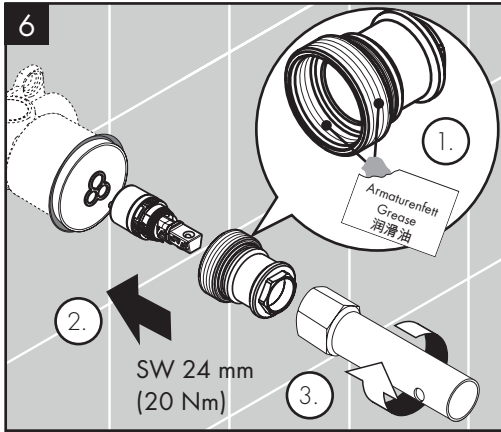

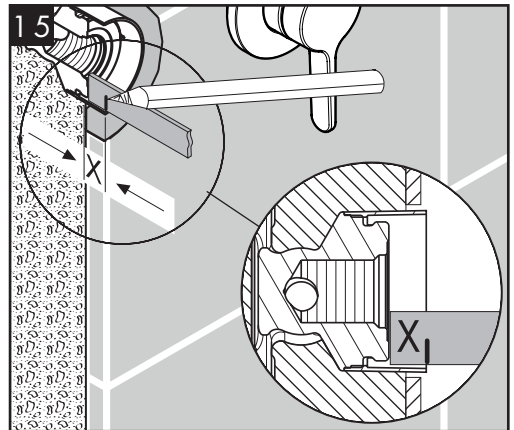
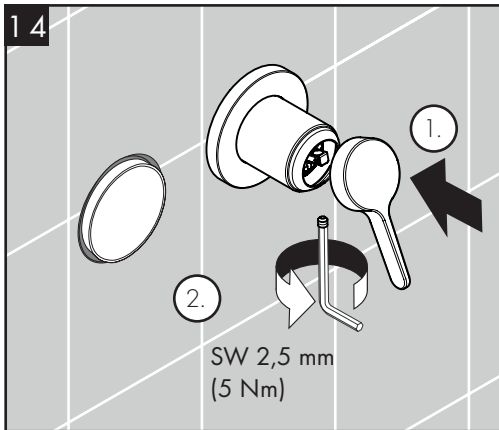
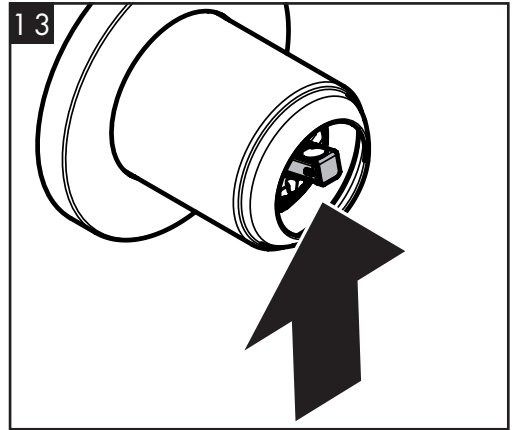
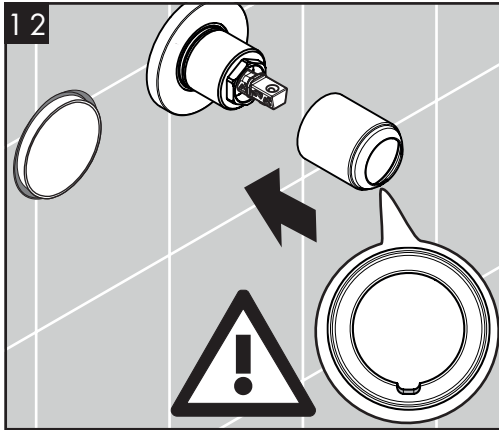
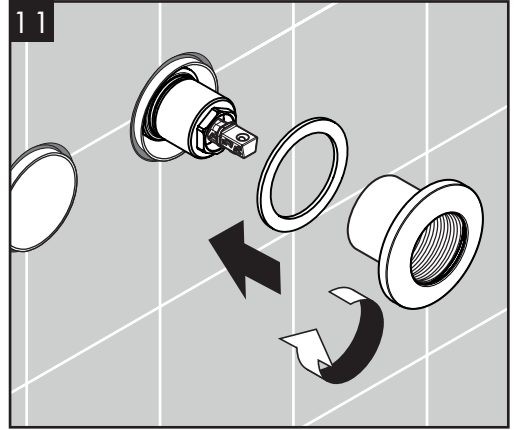
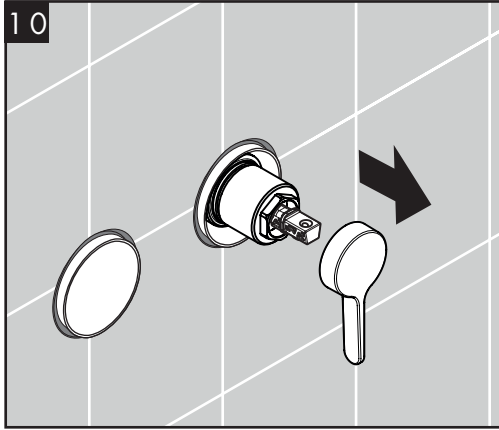

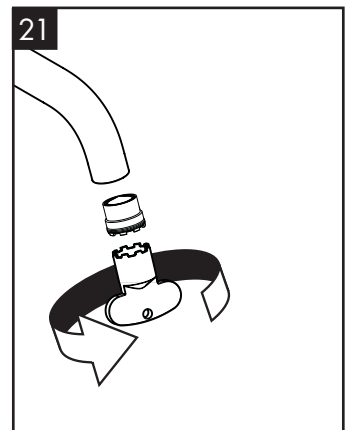
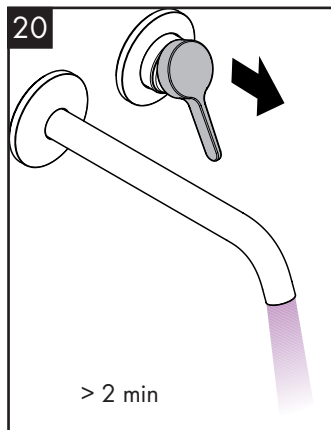
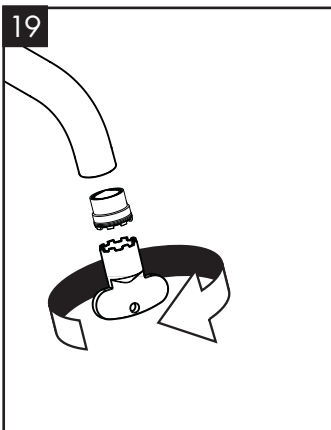
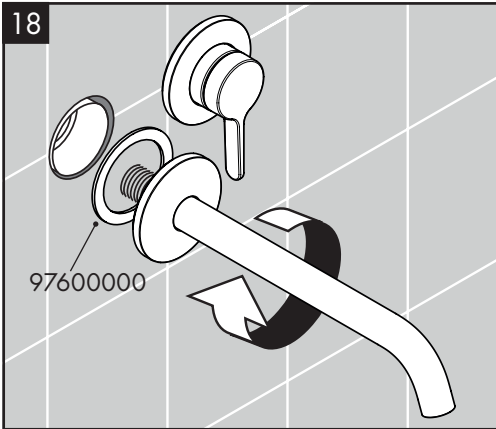
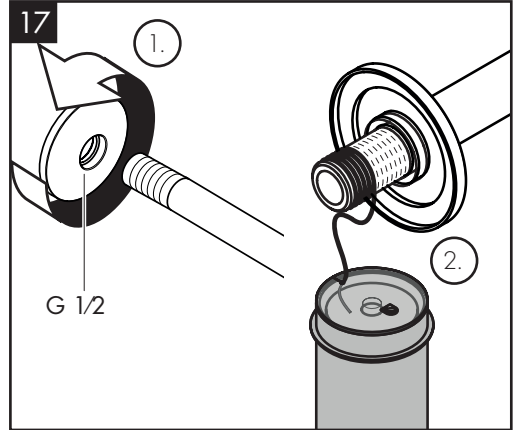
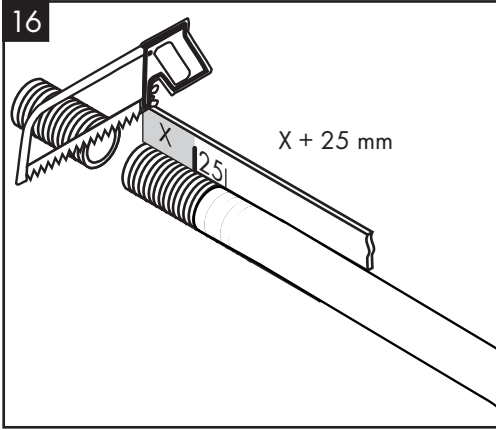

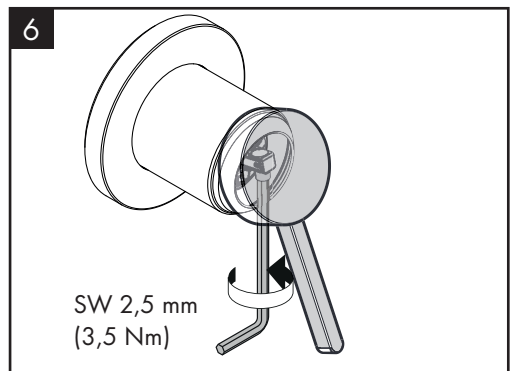
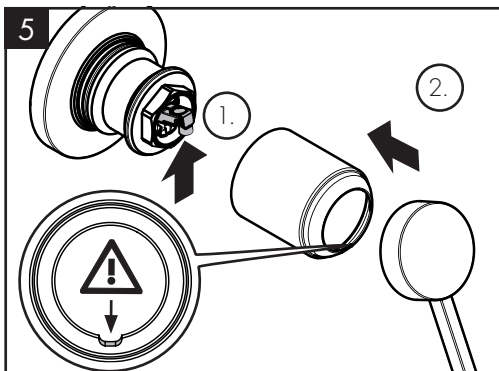
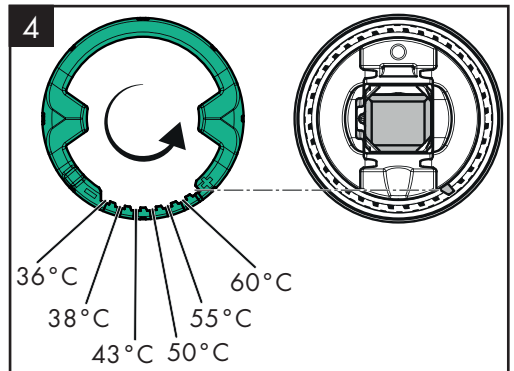
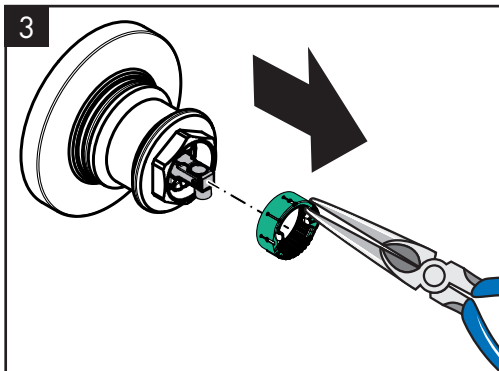
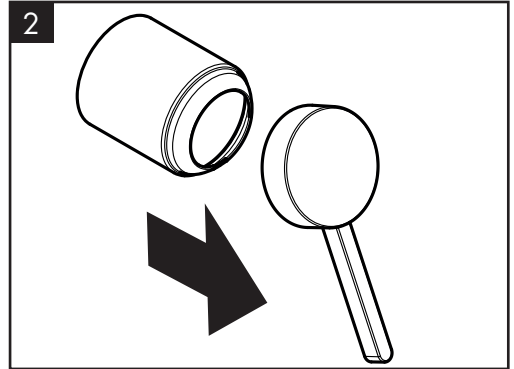
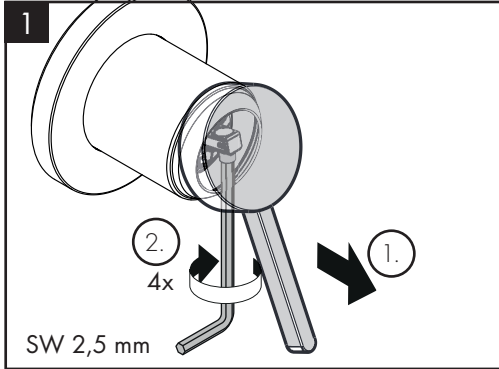



AXOR One
48120XXX

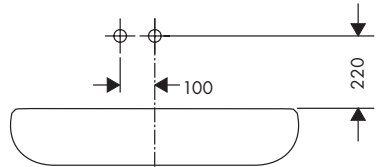
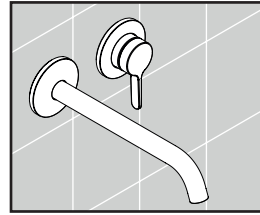
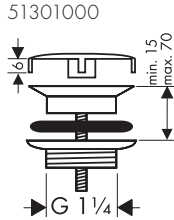
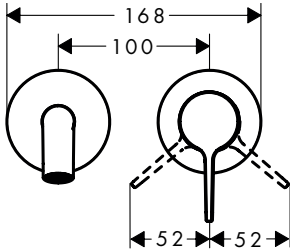
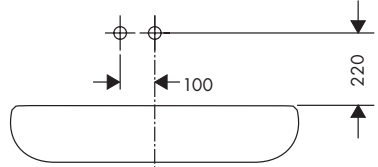
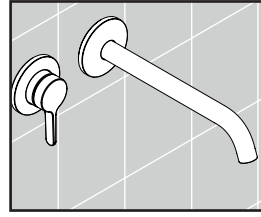
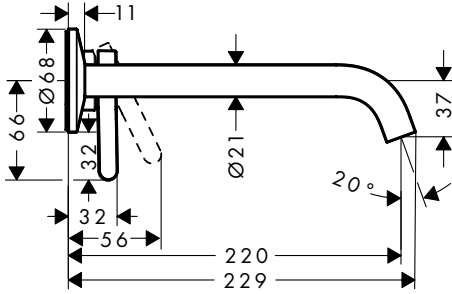

AXOR One
48120XXX

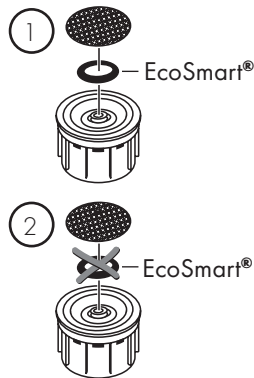
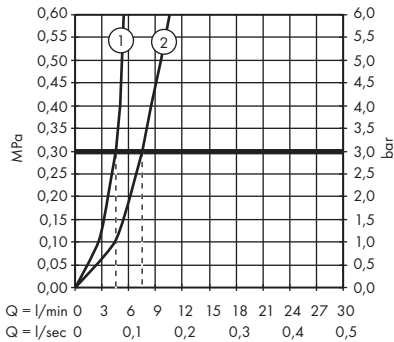



DE / Reinigungsempfehlung / Garantie / Kontakt
 FR / Recommandation pour le nettoyage / Garanties / Contact
 EN / Cleaning recommendation / Warranty / Contact
 IT / Raccomandazione di pulizia / Garanzia / Contatto
 ES / Recomendaciones para la limpieza / Garantía / Contacto
 NL / Aanbevelingen inzake reiniging / Garantie / Contact
 DK / Rengøringsvejledning / Garanti / Kontakt
 PT / Recomendações de limpeza / Garantia / Contacto
 PL / Zalecenie dotyczące pielęgnacji / Gwarancja / Kontakt
 CS / Doporučení k čištění / Záruka / Kontakt
 SK / Odporúčania pre čistenie / Záruka / Kontakt
 ZH / 清洁指南 / 担保 / 接触
 RU / Рекомендации по очистке / Гарантия / Контакты
 FI / Puhdistussuositus / Takuu / Kosketus
 SV / Rengöringsrekommendationer / Garanti / Contacto
 LT / Valymo rekomendacijos / Garantija / Kontaktai
 HR / Preporuke za čišćenje / Garancija / Kontakt
 TR / Temizleme önerisi / Garanti / Temas
 RO / Recomandări pentru curățare / Garanție / Contact
 EL / Σύσταση καθαρισμού / Εγγύηση / επαφή
 SL / Priporočilo za čiščenje / Garancija / Kontakt
 ET / Puhastussooitused / Garantii / Kontakt
 LV / Tīrīšanas ieteikumi / Garantija / Kontakti
 SR / Preporuke za čišćenje / Garancija / Kontakt
 NO / Anbefaling for rengjøring / Garanti / Kontakt
 BG / Препоръка за почистване / Гаранция / Контакт
 SQ / Këshilla rreth pastrimit / Garancia / Kontakt
 KO / 세정시 권장사항 / 품질보증 / 접촉
 AR / توصيات التنظيف / الضمان (الولايات المتحدة الأمريكية) / اتصال
 HU / Tisztítási tanácsok / Garancia / érintkezés
 JP / お手入れの方法 / 保証について / ご連絡先



[www.axor-design.com/
cleaning-recommendation](http://www.axor-design.com/cleaning-recommendation)

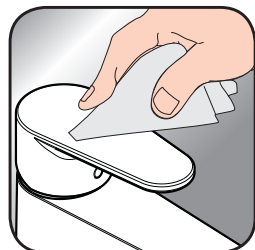

[www.axor-design.com/
cleaning-recommendation](http://www.axor-design.com/cleaning-recommendation)



[www.axor-design.com/
cleaning-recommendation](http://www.axor-design.com/cleaning-recommendation)

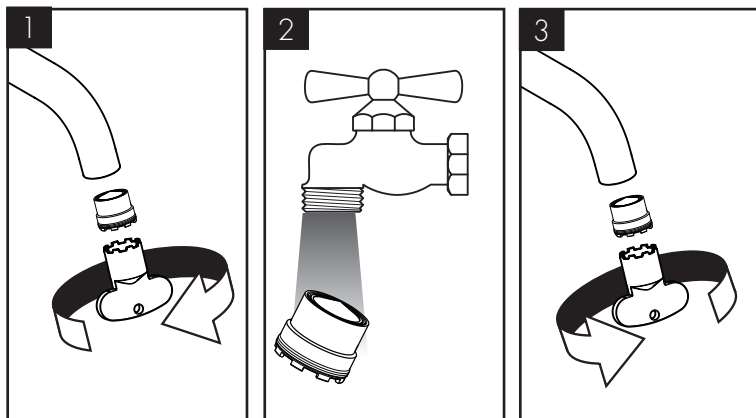

[www.axor-design.com/
cleaning-recommendation](http://www.axor-design.com/cleaning-recommendation)



AXOR One
48120XXX

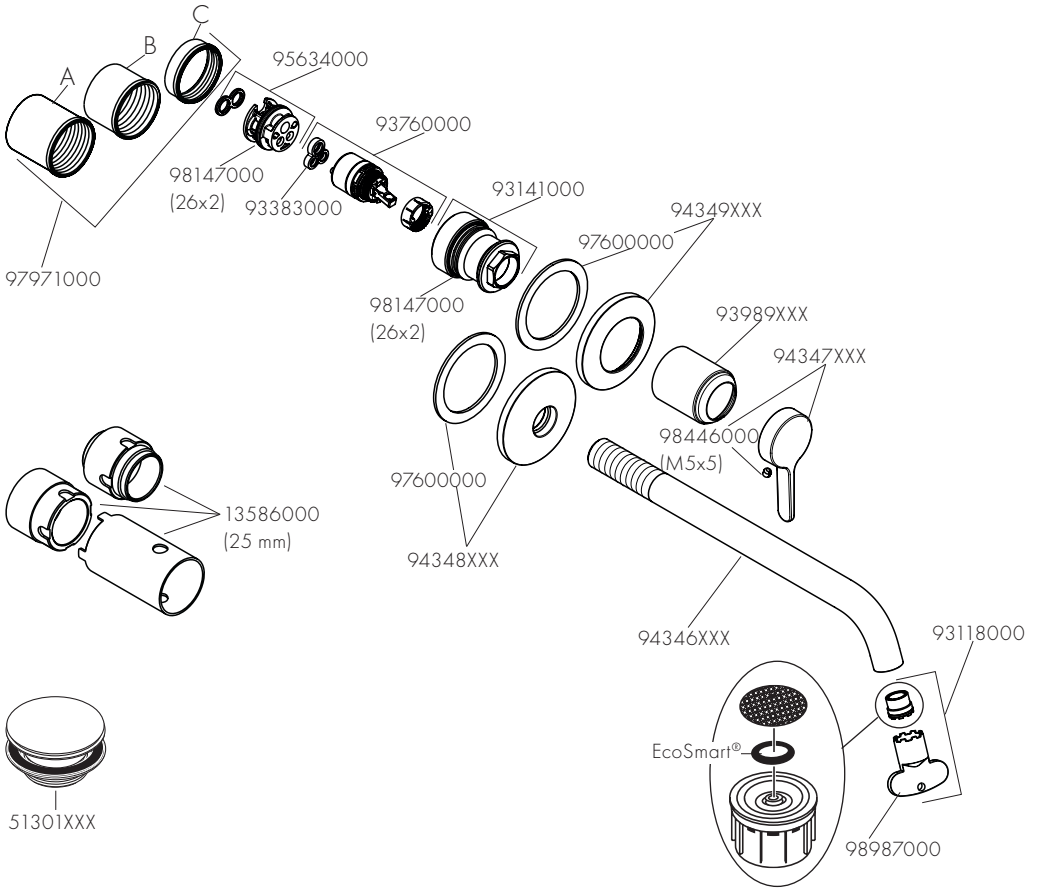

P-IX

DVGW SINTEF NF



48120XXX PA-IX 38034/IO

Hansgrohe SE

DIN 4109-1

PA-IX 38034/IO



AXOR

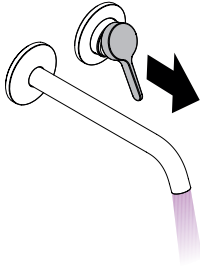

öffnen / ouvert / open / aperto / abierto / open / åbne /
abrir / otworzyć / otevřít / otvorit / 开 / открыть / nyitás /
avaaminen / öppna / atidaryti / Otvaranje / açmak /
deschide / ανοικτό / odpreti / avage / atvērt / otvoriti /
årne / отворяне / hare / فتح / 開く

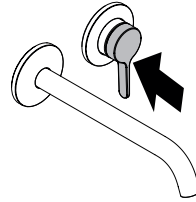

schließen / fermé / close / chiudere / cerrar / sluiten /
lukke / fechar / zamknąć / zavřít / uzavrieť / 关 /
закреть / bezárás / sulkeminen / stänga / uždaryti /
Zatvaranje / kapatmak / închide / κλειστό / zapreti /
sulgege / aizvērt / zatvori / lukke / затворяне / mbylle /
إغلاق / 閉じる

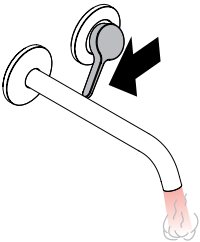

warm / chaud / hot / caldo / caliente / warm / varmt /
quente / ciepła / teplá / teplá / 热 / горячая / meleg /
lämmin / varmt / karštas / Vruća voda / sıcak / cald /
ζεστό / toplo / kuum / karsts / topla / varm / тепло /
i ngrohtë / ساخن / 温かい

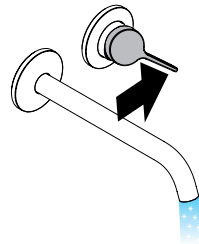

kalt / froid / cold / freddo / frío / koud / koldt / fria /
zimna / studená / studená / 冷 / холодная / hideg /
kylmä / kallt / šaltas / Hladno / soğuk / rece / κρύο /
mrzlo / külm / auksts / hladno / kaldt / студено /
i ftohtë / بارد / 冷たい

AXOR / Hansgrohe SE

Austraße 5-9

77761 Schiltach

Deutschland

info@axor-design.com

axor-design.com