

<b>DE</b>	Gebrauchsanleitung / Montageanleitung	<b>2</b>
<b>FR</b>	Mode d'emploi / Instructions de montage	<b>2</b>
<b>EN</b>	Instructions for use / assembly instructions	<b>3</b>
<b>IT</b>	Istruzioni per l'uso / Istruzioni per Installazione	<b>3</b>
<b>ES</b>	Modo de empleo / Instrucciones de montaje	<b>4</b>
<b>NL</b>	Gebruiksaanwijzing / Handleiding	<b>4</b>
<b>DK</b>	Brugsanvisning / Monteringsvejledning	<b>5</b>
<b>PT</b>	Instruções para uso / Manual de Instalação	<b>5</b>
<b>PL</b>	Instrukcja obsługi / Instrukcja montażu	<b>6</b>
<b>CS</b>	Návod k použití / Montážní návod	<b>6</b>
<b>SK</b>	Návod na použitie / Montážny návod	<b>7</b>
<b>ZH</b>	用户手册 / 组装说明	<b>7</b>
<b>RU</b>	Руководство пользователя / Инструкция по монтажу	<b>8</b>
<b>HU</b>	Használati útmutató / Szerelési útmutató	<b>8</b>
<b>FI</b>	Käyttöohje / Asennusohje	<b>9</b>
<b>SV</b>	Bruksanvisning / Monteringsanvisning	<b>9</b>
<b>LT</b>	Vartotojo instrukcija / Montavimo instrukcijos	<b>10</b>
<b>HR</b>	Upute za uporabu / Uputstva za instalaciju	<b>10</b>
<b>TR</b>	Kullanım kılavuzu / Montaj kılavuzu	<b>11</b>
<b>RO</b>	Manual de utilizare / Instrucțiuni de montare	<b>11</b>
<b>EL</b>	Οδηγίες χρήσης / Οδηγία συναρμολόγησης	<b>12</b>
<b>SL</b>	Navodilo za uporabo / Navodila za montažo	<b>12</b>
<b>ET</b>	Kasutusjuhend / Paigaldusjuhend	<b>13</b>
<b>LV</b>	Lietošanas pamācība / Montāžas instrukcija	<b>13</b>
<b>SR</b>	Uputstvo za upotrebu / Uputstvo za montažu	<b>14</b>
<b>NO</b>	Bruksanvisning / Montasjeveiledning	<b>14</b>
<b>BG</b>	Инструкция за употреба / Ръководство за монтаж	<b>15</b>
<b>SQ</b>	Udhëzuesi i përdorimit / Udhëzime rreth montimit	<b>15</b>
<b>AR</b>	دليل الاستخدام / تعليمات التجميع	<b>16</b>

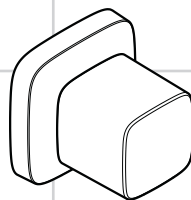

**PuraVida**  
15978XXX

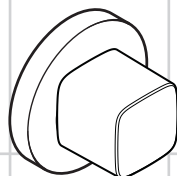

**Metris**  
31677000

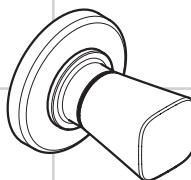

**Logis**  
71970000

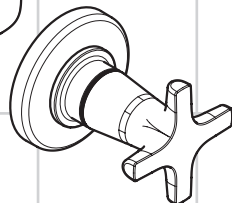

**Logis Classic**  
71976000



## Sicherheitshinweise

- Bei der Montage müssen zur Vermeidung von Quetsch- und Schnittverletzungen Handschuhe getragen werden.

## Montagehinweise

- Vor der Montage muss das Produkt auf Transportschäden untersucht werden. Nach dem Einbau werden keine Transport- oder Oberflächenschäden anerkannt.
- Die Leitungen und die Armatur müssen nach den gültigen Normen montiert, gespült und geprüft werden.
- Die in den Ländern jeweils gültigen Installationsrichtlinien sind einzuhalten.

## Symbolerklärung



Kein essigsäurehaltiges Silikon verwenden!



**Maße** (siehe Seite 20)



**Serviceteile** (siehe Seite 21)

XXX = Farbcodierung  
 000 = chrom  
 400 = weiß/chrom



**Prüfzeichen** (siehe Seite 24)



**Reinigung** (siehe beiliegende Broschüre)



## Consignes de sécurité

- Lors du montage, porter des gants de protection pour éviter toute blessure par écrasement ou coupure.

## Instructions pour le montage

- Avant son montage, s'assurer que le produit n'a subi aucun dommage pendant le transport. Après le montage, tout dommage de transport ou de surface ne pourra pas être reconnu.
- Les conduites et la robinetterie doivent être montés, rincés et contrôlés selon les normes en vigueur.
- Les directives d'installation en vigueur dans le pays concerné doivent être respectées.

## Description du symbole



Ne pas utiliser de silicone contenant de l'acide acétique!



**Dimensions** (voir pages 20)



**Pièces détachées** (voir pages 21)

XXX = Couleurs  
 000 = chromé  
 400 = blanc/chromé



**Classification acoustique et débit** (voir pages 24)



**Nettoyage** (voir la brochure ci-jointe)



**Montage**  
siehe Seite 17

**Montage**  
voir pages 17



### Safety Notes

- ⚠ Gloves should be worn during installation to prevent crushing and cutting injuries.

### Installation Instructions

- Prior to installation, inspect the product for transport damages. After it has been installed, no transport or surface damage will be honoured.
- The pipes and the fixture must be installed, flushed and tested as per the applicable standards.
- The plumbing codes applicable in the respective countries must be observed.

### Symbol description



Do not use silicone containing acetic acid!



**Dimensions** (see page 20)



**Spare parts** (see page 21)

XXX = Colors

000 = chrome plated

400 = white/chrome plated

### Indicazioni sulla sicurezza

- ⚠ Durante il montaggio, per evitare ferite da schiacciamento e da taglio bisogna indossare guanti protettivi.

### Istruzioni per il montaggio

- Prima del montaggio è necessario controllare che non ci siano stati danni durante il trasporto. Una volta eseguito il montaggio, non verranno riconosciuti eventuali danni di trasporto o delle superfici.
- Montare, lavare e controllare tubature e rubinetteria rispettando le norme correnti.
- Vanno rispettate le direttive di installazione nazionali vigenti nel rispettivo paese.

### Descrizione simbolo



Non utilizzare silicone contenente acido acetico!



**Ingombri** (vedi pagg. 20)



**Parti di ricambio** (vedi pagg. 21)

XXX = Trattamento

000 = cromato

400 = bianco/cromato



**Test certificate** (see page 24)



**Cleaning** (see enclosed brochure)



**Segno di verifica** (vedi pagg. 24)



**Pulitura** (vedi il prospetto accluso)

**Assembly**  
see page 17



**Montaggio**  
vedi pagg. 17



## Indicaciones de seguridad

- ⚠ Durante el montaje deben utilizarse guantes para evitar heridas por aplastamiento o corte.

## Indicaciones para el montaje

- Antes del montaje se debe examinarse el producto contra daños de transporte. Después de la instalación so se reconoce ningún daño de transporte o de superficie.
- Los conductos y la grifería deben montarse, lavarse y comprobarse según las normas vigentes.
- Es obligatorio el cumplimiento de las directrices de instalación vigentes en el país respectivo.

## Descripción de símbolos



No utilizar silicona que contiene ácido acético!



**Dimensiones** (ver página 20)



**Repuestos** (ver página 21)

XXX = Acabados  
000 = cromado  
400 = blanco/cromado



**Marca de verificación** (ver página 24)



**Limpiar** (ver el folleto adjunto)



## Veiligheidsinstructies

- ⚠ Bij de montage moeten ter voorkoming van knel- en snijwonden handschoenen worden gedragen.

## Montage-instructies

- Vóór de montage moet het product gecontroleerd worden op transportschade. Na de inbouw wordt geen transport- of oppervlakteschade meer aanvaard.
- De leidingen en armaturen moeten gemonteerd, gespoeld en gecontroleerd worden volgens de geldige normen.
- De in de overeenkomstige landen geldende installatierichtlijnen moeten nageleefd worden.

## Symboolbeschrijving



Gebruik geen zuurhoudende siliconen!



**Maten** (zie blz. 20)



**Service onderdelen** (zie blz. 21)

XXX = Kleuren  
000 = verchromd  
400 = wit/verchromd



**Keurmerk** (zie blz. 24)



**Reinigen** (zie bijgevoegde brochure)





## Sikkerhedsanvisninger

- ⚠ Ved monteringen skal der bruges handsker for at undgå kvæstelser og snitsår.

## Monteringsanvisninger

- Før monteringen skal produktet kontrolleres for transportskader. Efter monteringen godkendes transportskader eller skader på overfladen ikke længere.
- Ledningerne og armaturerne skal monteres, skylles og kontrolleres iht. de gældende standarder.
- Installationsbestemmelserne, der gælder i det enkelte land, skal overholdes.

## Symbolbeskrivelse



Der må ikke benyttes eddikesyreholdig silikone!



**Målene** (se s. 20)



**Reserve dele** (se s. 21)

XXX = Overflade  
000 = Krom  
400 = Hvid/Krom



**Godkendelse** (se s. 24)



**Rengøring** (se venligst den vedlagte brochure)

## Avisos de segurança

- ⚠ Durante a montagem devem ser utilizadas luvas de protecção, de modo a evitar ferimentos resultantes de entalamentos e de cortes.

## Avisos de montagem

- Antes da montagem deve-se controlar o produto relativamente a danos de transporte. Após a montagem não são aceites quaisquer danos de transporte ou de superfície.
- As tubagens e a torneira têm que ser montadas, enxaguadas e verificadas de acordo com as normas em vigor.
- A prescrições de instalação válidas nos respetivos países devem ser respeitadas.

## Descrição do símbolo



Não utilizar silicone que contenha ácido acético!



**Medidas** (ver página 20)



**Peças de substituição** (ver página 21)

XXX = Acabamentos  
000 = cromado  
400 = branco/cromado



**Marca de controlo** (ver página 24)



**Limpeza** (consultar a seguinte brochura)





## Wskazówki bezpieczeństwa

- ⚠ Aby uniknąć zranień, takich jak zgniecenia czy przecięcia, podczas montażu należy nosić rękawice.

## Bezpečnostní pokyny

- ⚠ Pro zabránění řezným zraněním a pohmožděním je nutné při montáži nosit rukavice.

## Wskazówki montażowe

- Przed montażem należy skontrolować produkt pod kątem szkód transportowych. Po montażu nie widać żadnych szkód transportowych ani szkód na powierzchni.
- Przewody i armatura muszą być montowane, płukane i kontrolowane według obowiązujących norm.
- Należy przestrzegać wytycznych instalacyjnych obowiązujących w danym kraju.

## Pokyny k montáži

- Před montáží je třeba produkt zkontrolovat, zda nebyl při transportu poškozen. Po zabudování nebudou uznány žádné škody způsobené transportem nebo poškození povrchu.
- Vedení a armatura musí být namontovány, propláchnuty a otestovány podle platných norem.
- Je třeba dodržovat montážní pravidla platné v dané zemi.

## Opis symbolu



Nie stosować silikonów zawierających kwas octowy!



**Wymiary** (patrz strona 20)



**Części serwisowe** (patrz strona 21)

XXX = Kody kolorów  
000 = chrom  
400 = biały/chrom

## Popis symbolů



Nepoužívat silikon s obsahem kyseliny octové!



**Rozměry** (viz strana 20)



**Servisní díly** (viz strana 21)

XXX = Kód povrchové úpravy  
000 = chrom  
400 = bílý/chrom



**Znak jakości** (patrz strona 24)



**Czyszczenie** (patrz dołączona broszura)



**Zkušební značka** (viz strana 24)



**Čištění** (viz přiložená brožura)





## Bezpečnostné pokyny

- △ Pri montáži musíte nosiť rukavice, aby ste predišli pomliaždeninám a rezným poraneniam.

## Pokyny pre montáž

- Pred montážou musíte produkt skontrolovať, či nebol počas transportu poškodený. Po zabudovaní nebudú uznané žiadne škody spôsobené transportom alebo poškodenia povrchu.
- Ledningarna och blandaren måste monteras, spolás igenom och kontrolleras enligt de gällande normerna.
- Je potrebné dodržiavať smernice o inštalácii, ktoré sú práve teraz platné v krajinách.

## Popis symbolov



Nepoužívať silikón s obsahom kyseliny octovej!



**Rozmery** (viď strana 20)



**Servisné diely** (viď strana 21)

XXX = Farebné označenie

000 = chróm

400 = biela/chróm

## 安全技巧

- △ 装配时为避免挤压和切割受伤，必须戴上手套。

## 安装提示

- 安装前必须检查产品是否受到运输损害。安装后将不认可运输损害或表面损伤。
- 管道和阀门必须根据通用标准进行安装、冲洗和检查。
- 请遵守当地国家现行的安装规定。

## 符号说明



请勿使用含有乙酸的硅！



大小 (参见第页 20)



备用零件 (参见第页 21)

XXX = 颜色代码

000 = 镀铬

400 = 白色/镀铬



## Osvedčenie o skúške

(viď strana 24)



**Čistenie** (nájdete v priloženej brožúre)



检验标记 (参见第页 24)



清洗 (附有小手册)

**Montáž**  
viď strana 17



**安装**  
参见第页 17



## Указания по технике безопасности

- Во время монтажа следует надеть перчатки во избежание прищемления и порезов.

## Указания по монтажу

- Перед монтажом следует проверить изделие на предмет повреждений при перевозке. После монтажа претензии о возмещении ущерба за повреждения при перевозке или повреждения поверхностей не принимаются.
- Трубы и арматура должны быть установлены, промыты и проверены в соответствии с действующими нормами.
- Необходимо соблюдать требования по монтажу, действующие в соответствующих странах.

## Описание символов



Не применяйте силикон, содержащий уксусную кислоту.



**Размеры** (см. стр. 20)



**Комплект** (см. стр. 21)

XXX = Цветная кодировка  
000 = хром  
400 = белый/хром



**Знак технического контроля**  
(см. стр. 24)



**Очистка** (см прилагаемая брошюра)

## Biztonsági utasítások

- A szerelésnél a zúzódások és vágási sérülések elkerülése érdekében kesztyűt kell viselni.

## Szerelési utasítások

- A szerelés előtt ellenőrizni kell, hogy a terméknek nincs-e szállítási sérülése. Beépítés után a szállítási vagy felületi sérüléseket nem ismerik el.
- A vezetékeket és a csaptelepet az érvényes szabványoknak megfelelően kell felszerelni, öblíteni és ellenőrizni
- Az egyes országokban érvényes installációs irányelveket be kell tartani.

## Szimbólumok leírása



Ne használjon ecetsavtartalmú szilikon!



**Méretet** (lásd a oldalon 20)



**Tartozékok** (lásd a oldalon 21)

XXX = Színkódolás  
000 = króm  
400 = fehér/króm



**Vizsgajel** (lásd a oldalon 24)



**Tisztítás** (lásd a mellékelt broszúrát)







## Turvallisuusohjeet

- Asennuksessa on käytettävä käsiineitä puristumien ja viiltojen aiheuttamien tapaturmien estämiseksi.

## Asennusohjeet

- Ennen asennusta on tarkastettava tuotteen mahdolliset kuljetusvahingot. Asennuksen jälkeen kuljetus- ja pintavaurioita ei hyväksytä.
- Putket ja hana on asennettava, huuhdeltava ja tarkastettava voimassa olevien standardien mukaisesti.
- Jokaisessa maassa on noudatettava siellä päteviä asennusohjeita.

## Merkin kuvaus



Älä käytä etikahappopitoista silikonია!



**Mitat** (katso sivu 20)



**Varaosat** (katso sivu 21)

XXX = Värikoodaus

000 = kromi

400 = valkoinen/kromi

## Säkerhetsanvisningar

- Handskar ska bäras under monteringsarbetet så att man kan undvika kläm- och skärskadorgen werden.

## Monteringsanvisningar

- Det måste undersökas om produkten har transportskador innan den monteras. Efter monteringen accepteras inga transport- eller ytskiktsskador.
- Ledningarna och blandaren måste monteras, spolas igenom och kontrolleras enligt de gällande normerna.
- De installationsriktlinjer som gäller i länderna ska följas.

## Symbolförklaring



Använd inte silikon som innehåller ättiksyra!



**Måtten** (se sidan 20)



**Reservdelar** (se sidan 21)

XXX = Färgkodning

000 = krom

400 = vit/krom



**Koestusmerkki** (katso sivu 24)



**Puhdistus** (katso oheinen esite)



**Testsigill** (se sidan 24)



**Rengöring** (se den medföljande broschyren)

**Asennus**  
**katso sivu 17**



**Montering**  
**se sidan 17**



## Saugumo technikos nurodymai

- ⚠ Apsaugai nuo užspaudimo ir įsijpavimo montavimo metu mūvėkite pirštines.



## Sigurnosne upute

- ⚠ Prilikom montaže se radi sprječavanja prignječenja i posjekotina moraju nositi rukavice.

## Montavimo instrukcija

- Prieš montuojant būtina patikrinti, ar gaminy nebuvu pažeistas transportavimo metu. Sumontavus pretenzijos dėl transportavimo ir paviršiaus pažeidimų nepriimamos.
- Vamzdžiai ir sujungimai turi būti montuojami, plaunami ir tikrinami pagal galiojančias normas.
- Laikykitės atitinkamoje šalyje galiojančių direktyvų dėl įrengimo.

## Upute za montažu

- Prije montaže mora se provjeriti je li proizvod oštećen prilikom transporta. Nakon ugradnje se ne priznaju nikakve reklamacije koje se odnose na površinska i transportna oštećenja.
- Cijevi i armatura moraju biti postavljeni, isprani i testirani prema važećim normama.
- Obvezno se moraju uvažiti propisi o instalacijama koji vrijede u dotičnoj zemlji.

## Simbolio aprašymas



Nenaudokite silikono, kurio sudėtyje yra acto rūgšties!



**Išmatavimai** (žr. psl. 20)



**Atsarginės dalys** (žr. psl. 21)

XXX = Spalvos  
000 = chrom  
400 = balta/chrom

## Opis simbola



Nemojte koristiti silikon koji sadrži octenu kiselinu!



**Mjere** (pogledaj stranicu 20)



**Rezervni djelovi** (pogledaj stranicu 21)

XXX = Boje  
000 = krom  
400 = bijela/krom



**Bandymo pažyma** (žr. psl. 24)



**Valymas** (žr. pridedamoje brošiūroje)



**Oznaka testiranja** (pogledaj stranicu 24)



**Čišćenje** (se u priloženoj brošuri)





### ⚠ Güvenlik uyarıları

- ⚠ Montaj esnasında ezilme ve kesilme gibi yaralanmaları önlemek için eldiven kullanılmalıdır.

### Montaj açıklamaları

- Montaj işleminden önce ürün nakliye hasarları yönünden kontrol edilmelidir. Montaj işleminden sonra nakliye veya yüzey hasarları için sorumluluk üstlenilmemektedir.
- Boruların ve armatürün montajı, yıkanması ve kontrolü geçerli normlara göre yapılmalıdır.
- Ülkelerde geçerli kurulum yönetmeliklerine riayet edilmelidir.

### ⚠ Instrucțiuni de siguranță

- ⚠ La montare utilizați mănuși pentru evitarea contuziunilor și tăierii mâinilor.

### Instrucțiuni de montare

- Înainte de instalare verificați, dacă produsul prezintă deteriorări de transport. După instalare garanția nu acoperă deteriorările de transport și cele de suprafață.
- Conductele și bateriile trebuie montate, spălate și verificate conform normelor în vigoare.
- Respectați reglementările referitoare la instalare valabile în țara respectivă.

### Simge açıklaması



Asetik asit içeren silikon kullanmayın!



**Ölçüleri** (bakınız sayfa 20)



**Yedek Parçalar** (bakınız sayfa 21)

XXX = Renkler  
000 = krom  
400 = beyaz/Krom

### Descrierea simbolurilor



Nu utilizați silicon cu conținut de acid acetic!



**Dimensiuni** (vezi pag. 20)



**Piese de schimb** (vezi pag. 21)

XXX = Coduri de culori  
000 = crom  
400 = alb/crom



**Kontrol işareti** (bakınız sayfa 24)



**Temizleme** (birlikte verilen broşür)



**Certificat de testare** (vezi pag. 24)



**Curățare** (vezi broșura alăturată)

**Montajı**  
**bakınız sayfa 17**



**Montare**  
**vezi pag. 17**



## Υποδειξεις ασφαλείας

- ⚠ Για να αποφύγετε τραυματισμούς κατά τη συναρμολόγηση πρέπει να φοράτε γάντια.

## Οδηγίες συναρμολόγησης

- Πριν τη συναρμολόγηση πρέπει να εξεταστεί το προϊόν για ζημιές μεταφοράς. Μετά την εγκατάσταση δεν αναγνωρίζονται ζημιές από τη μεταφορά ή επιφανειακές ζημιές.
- Οι σωλήνες και η μπαταρία πρέπει να τοποθετηθούν σύμφωνα με τα ισχύοντα πρότυπα, να τεθούν υπό πίεση και να δοκιμαστούν.
- Θα πρέπει να τηρούνται οι οδηγίες εγκατάστασης που ισχύουν σε κάθε κράτος.

## Varnostna opozorila

- ⚠ Pri montaži je treba nositi rokavice, da se preprečijo poškodbe zaradi zmečkanja ali urezov.

## Navodila za montažo

- Pred montažo je treba izdelek preveriti glede morebitnih transportnih poškodb. Po vgradnji transportne ali površinske poškodbe ne bodo več priznane.
- Cevi in armaturo je treba montirati, izprati in preveriti po veljavnih standardih.
- Uproštevati je treba pravilnike o inštalacijah, ki veljajo v posamezni državi.

## Περιγραφή συμβόλων



Μην χρησιμοποιείτε σιλικόνη που περιέχει οξικό οξύ!



**Διαστάσεις** (βλ. Σελίδα 20)



**Ανταλλακτικά** (βλ. Σελίδα 21)

XXX = Χρώματα

000 = Επιχρωμιωμένο

400 = λευκό/Επιχρωμιωμένο

## Opis simbola



Ne smete uporabiti silikona, ki vsebuje očetno kislino!



**Mere** (glejte stran 20)



**Rezervni deli** (glejte stran 21)

XXX = Barve

000 = krom

400 = bela/krom



**Σήμα ελέγχου** (βλ. Σελίδα 24)



**Καθαρισμός** (βλ. συνημμένο φυλλάδιο)



**Preskusni znak** (glejte stran 24)



**Čiščenje** (glejte priloženi brošuri)





## Ohutusjuhised

- ⚠ Kandke paigaldamisel muljumis- ja löikevigastuste vältimiseks kindaid.

## Paigaldamisjuhised

- Enne paigaldamist tuleb toodet kontrollida transportdikahjustuste osas. Pärast paigaldamist ei tunnustata enam transporti- või pinnakahjustuste kaebuseid.
- Voolikute ja segisti paigaldamisel, loputamisel ja kontrollimisel tuleb lähtuda kehtivatest normatiividest.
- Vastavas riigis kehtivaid paigalduseeskirju tuleb järgida.

## Drošības norādes

- ⚠ Montāžas laikā, lai izvairītos no saspiedumiem un iegriezumiem, nepieciešams nēsāt cimdus.

## Norādījumi montāžai

- Pirms montāžas nepieciešams pārbaudīt, vai produktam transportēšanas laikā nav radušies bojājumi. Pēc iebūvēšanas bojājumi, kas radušies transportēšanas laikā, vai virsmas bojājumi netiek atzīti.
- Cauruļvadi un armatūra ir jāuzstāda, jāizskalo un jāpārbauda saskaņā ar spēkā esošajiem standartiem.
- Jāievēro attiecīgās valstīs spēkā esošās montāžas prasības.

## Sümbolite kirjeldus



Ärge kasutage äädikhapet sisaldavat silikooni!



**Mõõtude** (vt lk 20)



**Varuosad** (vt lk 21)

XXX = Värvid

000 = kroom

400 = valge/kroom

## Simbolu nozīme



Neizmantoj silikonu, kas satur etiķskābi!



**Izmērus** (skat. lpp. 20)



**Rezerves daļas** (skat. lpp. 21)

XXX = Krāsu kodi

000 = hroma

400 = balta/hroma



**Kontrollsertifikaat** (vt lk 24)



**Puhastamine** (vt kaasasolevast brošüürist)



**Pārbaudes zīme** (skat. lpp. 24)



**Tīrīšana** (skatiet pievienotajā brošūrā)

**Paigaldamine**  
vt lk 17



**Montāža**  
skat. lpp. 17



## Sigurnosne napomene

- ⚠ Prilikom montaže se radi sprečavanja prignječanja i posekotina moraju nositi rukavice.

## Instrukcije za montažu

- Pre montaže se mora proveriti da li je proizvod oštećen pri transportu. Nakon ugradnje se ne priznaju nikakve reklamacije koje se odnose na površinska i transportna oštećenja.
- Vodovi i armatura moraju biti postavljeni, isprani i testirani prema važećim normama.
- Treba se pridržavati propisa koji u određenim zemljama važe za instalacije.

## Opis simbola



Nemojte koristiti silikon koji sadrži sirćetnu kiselinu!



**Mere** (vidi stranu 20)



**Rezervni delovi** (vidi stranu 21)

XXX = Oznake boja  
000 = hrom  
400 = bela/hrom



## Sikkerheshenvisninger

- ⚠ Bruk hansker under montasjen for å unngå klem- og kuttskader.

## Montagehenvisninger

- Før montasjen skal produktet sjekkes for transportskader. Etter monteringen aksepteres ikke noen transport- eller overflateskader.
- Ledningene og armaturen skal monteres, spyles og sjekkes iht. de gyldige normer.
- Gjeldende retningslinjer for rørleggerarbeid i de enkelte land skal følges.

## Symbolbeskrivelse



Ikke bruk silikon som inneholder eddiksyre!



**Mål** (se side 20)



**Servicedeler** (se side 21)

XXX = Fargekode  
000 = krom  
400 = hvit/krom



**Ispitni znak** (vidi stranu 24)



**Čišćenje** (vidi priloženoj brošuri)



**Prøvemerket** (se side 24)



**Rengjøring** (se vedlagt brosjyre)





## **Указания за безопасност**

- При монтажа трябва да се носят ръкавици, за да се избегнат наранявания поради притискане или порязване.

## **Указания за монтаж**

- Преди монтажа продуктът трябва да се провери за транспортни щети. След монтажа не се признават транспортни или повърхностни щети.
- Тръбопроводите и арматурата трябва да се монтират, промият и проверяват в съответствие с валидните норми.
- Трябва да бъдат спазвани валидните в съответните страни предписания за инсталиране.

## **Описание на символите**



Не използвайте силикон, съдържащ оцетна киселина!



**Размери** (вижте стр. 20)



**Сервизни части** (вижте стр. 21)

XXX = Цветово кодиране

000 = хром

400 = бял/хром

## **Udhëzime sigurie**

- При монтажа трябва да се носят ръкавици, за да се избегнат наранявания поради притискане или порязване.

## **Udhëzime për montimin**

- Përpara montimit duhet që produkti të kontrollohet për dëmtime nga transporti. Pas instalimit nuk do të njihet asnjë dëmtim nga transporti ose dëmtim i sipërfaqes.
- Tubacionet dhe rubinetet duhet që të montohen, të shpëlahen dhe të kontrollohen sipas standardeve në fuqi
- Duhet të respektohen linjat udhëzuese të instalimit, të vlefshme për vendet respektive.

## **Përshkrimi i simbolit**



Mos përdorni silikon që në përbërje ka acid acetik.



**Përmasat** (shih faqen 20)



**Pjesët e servisit** (shih faqen 21)

XXX = Kodimi me anë të ngjyrave

000 = krom

400 = e bardhë/krom



**Контролен знак** (вижте стр. 24)



**Почистване** (от приложената брошура)



**Shenja e kontrollit**

(shih faqen 24)



**Pastrimi** (shikoni broshurën bashkëngjitur)





## ⚠️ تنبيهات الأمان

⚠️ يجب إرتداء قفازات لليد أثناء التركيب لتجنب حدوث أخطار الإنحشار أو الجروح.

## تعليمات التركيب

- قبل القيام بعملية التركيب، يجب فحص المنتج للتأكد من خلوه من أية تلفيات ناتجة عن النقل. بعد القيام بعملية التركيب، لن يتم الاعتراف بوجود أية تلفيات سطحية أو تلفيات ناتجة عن عملية النقل.
- يجب تركيب وغسيل واختبار التوصيلات وخلطات المياه طبقاً للمعايير السارية.
- يجب مراعاة القواعد الخاصة بالتركيب وأعمال السباكة وفقاً للوائح الخاصة بكل بلد.

## وصف الرمز

هام! لا تستخدم السليكون الذي يحتوي على أمضاض!



أبعاد (راجع صفحة 20)

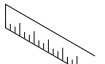

قطع الغيار (راجع صفحة 21)



XXX = الألوان

000 = كروم

400 = أبيض/كروم

شهادة اختبار (راجع صفحة 24)



التنظيف (راجع والكتيب المرفق)

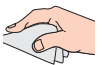

التركيب  
راجع صفحة 17





13973180 / 13974180 / 13975180  
07/92 - 04/01

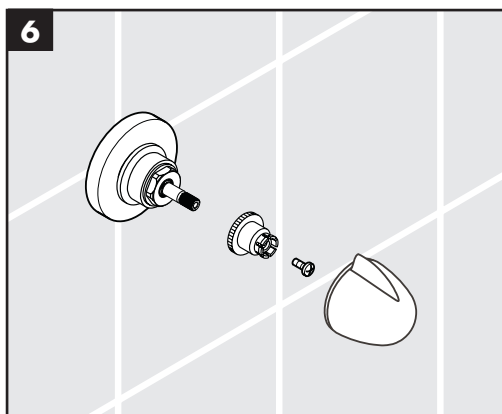
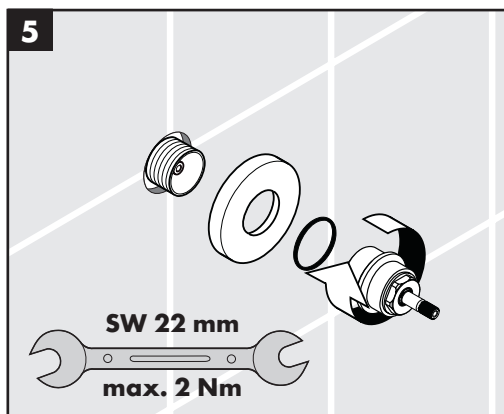
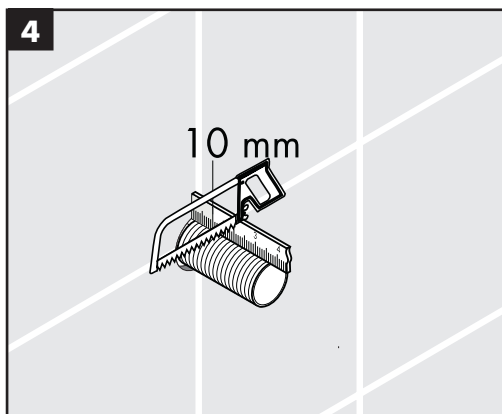
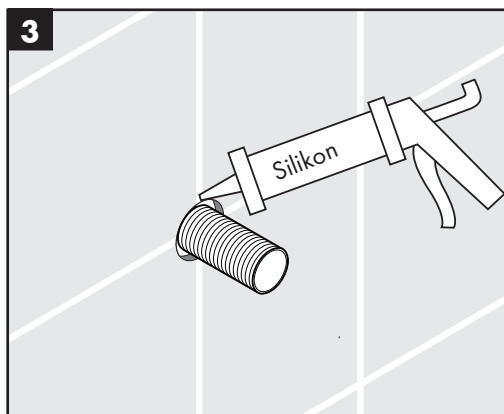
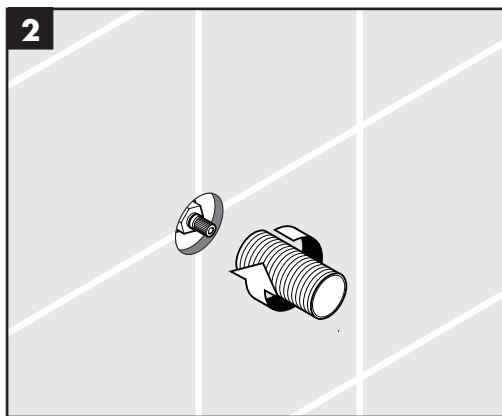
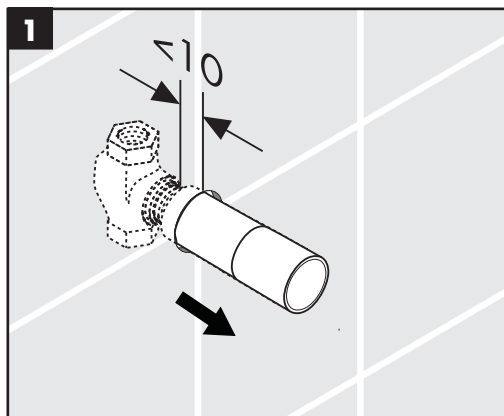



13973180 / 13974180 / 13975180  
07/92 - 04/01

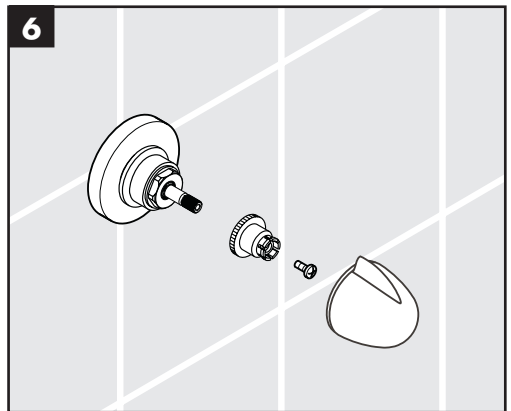
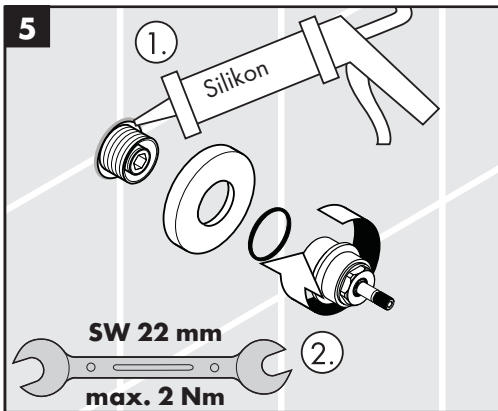
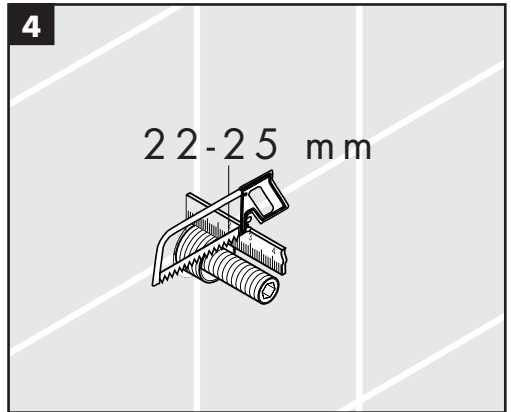
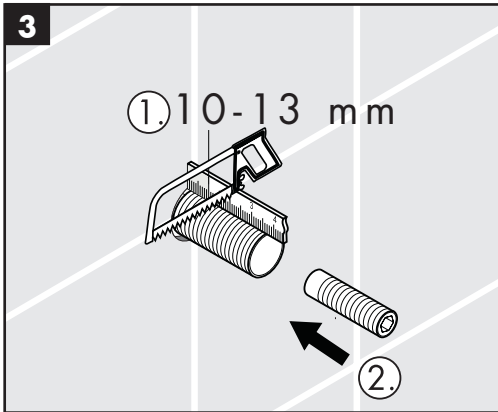
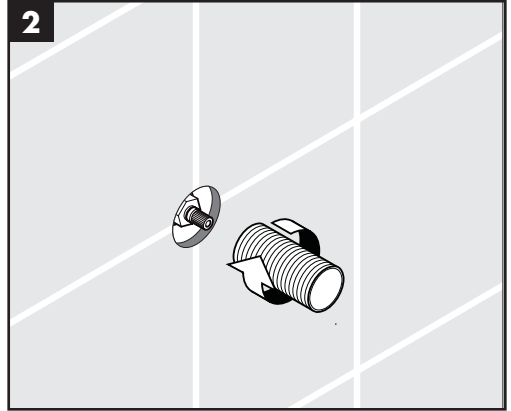
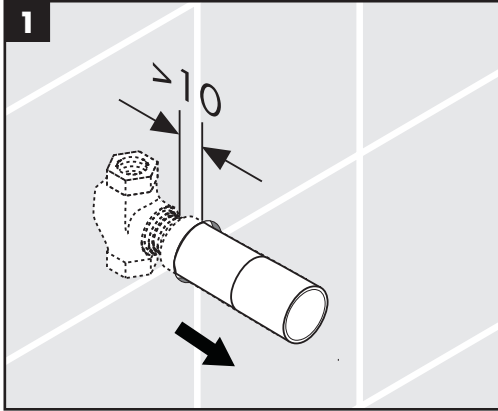



15970180 / 15973180 / 15974180  
> 05/01

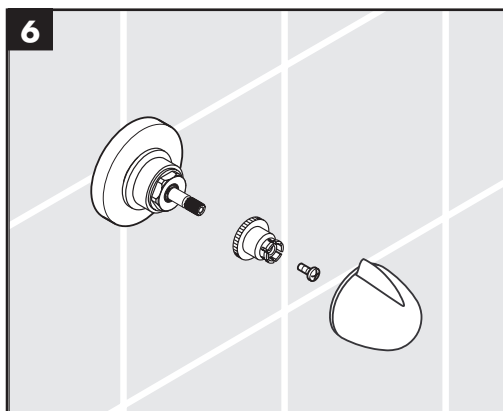
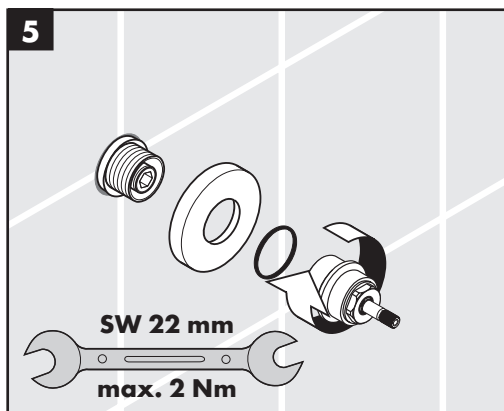
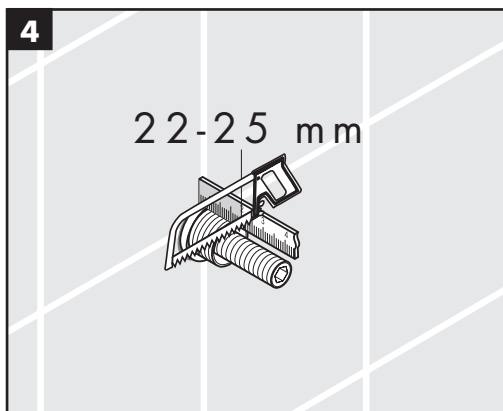
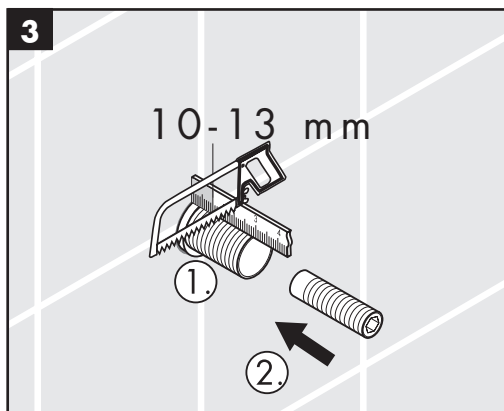
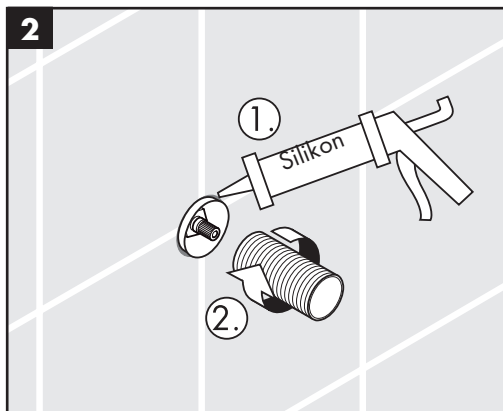
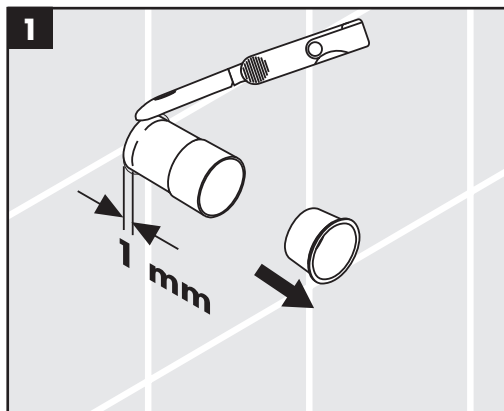



**PuraVida 15978XXX**

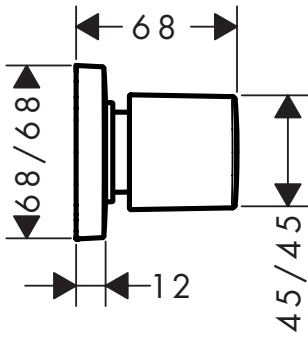

**Metris 31677000**

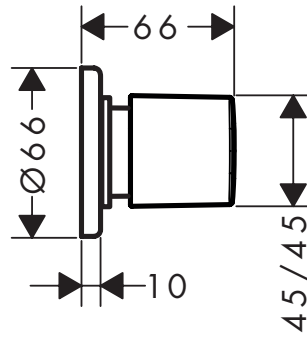

**Logis 71970000**

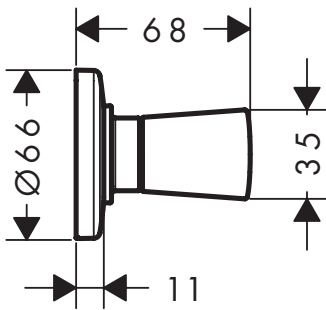

**Logis Classic 71976000**

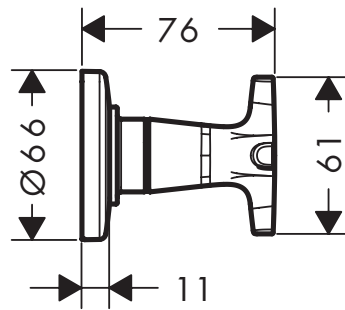



**Metris 31677000**

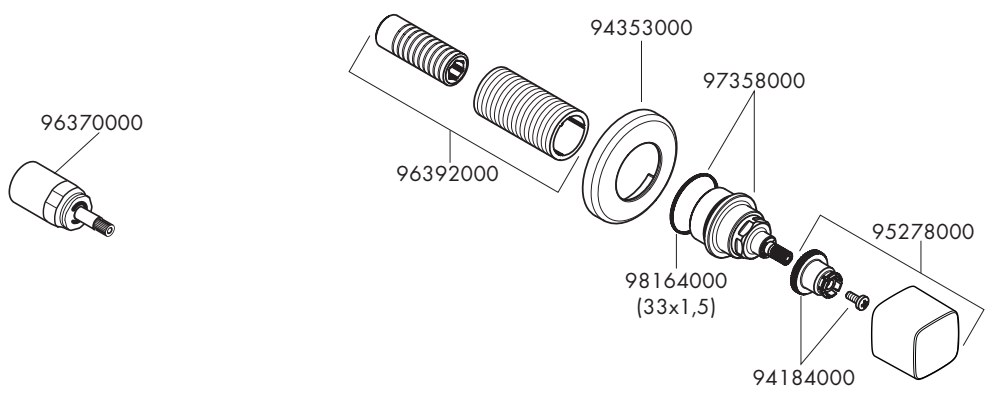

**PuraVida 15978XXX**

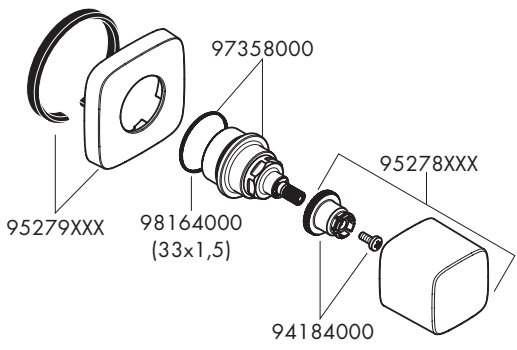

**Logis 71970000**  
**Logis Classic 71976000**

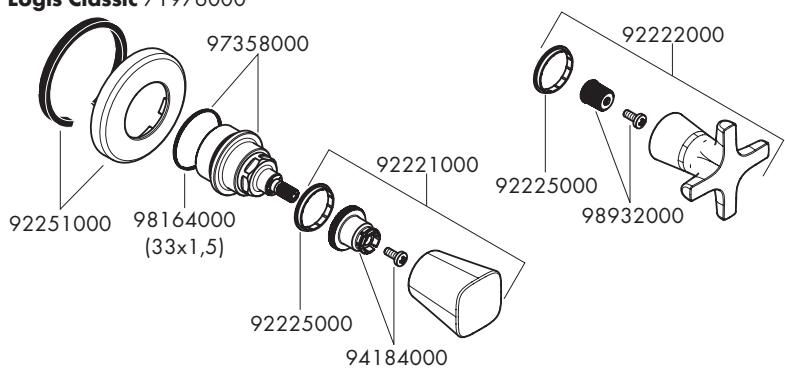







---

	<b>P-IX</b>	<b>DVGW</b>	<b>SVGW</b>	<b>NF</b>	<b>WRAS</b>	<b>KIWA</b>	<b>ACS</b>	<b>ETA</b>
<b>15978XXX</b>			X		X			
<b>31677000</b>					X			
<b>71970000</b>								
<b>71976000</b>								

---