

<b>EN</b> Table of contents	<b>1</b>
Instructions for use / assembly instructions	<b>2</b>
Troubleshooting	<b>3</b>
Assembly	<b>6</b>
Adjustment	<b>7</b>
Safety Function	<b>8</b>
Maintenance	<b>9 - 10</b>
Operation	<b>11 - 12</b>
Dimensions	<b>13</b>
Flow diagram	<b>13</b>
Spare parts	<b>14</b>
Test certificate	<b>15</b>
Cleaning	<b>16</b>
Contact information	<b>16</b>
<b>SV</b> Innehållsförteckning	<b>1</b>
Bruksanvisning / Monteringsanvisning	<b>4</b>
Felsökning	<b>5</b>
Montering	<b>6</b>
Inställning av maxtemperatur	<b>7</b>
Safety Function	<b>8</b>
Skötsel	<b>9 - 10</b>
Hantering	<b>11 - 12</b>
Måttskiss	<b>13</b>
Flödesschema	<b>13</b>
Reservdelar	<b>14</b>
Testsigill	<b>15</b>
Rengöring	<b>16</b>
Kontaktinformation	<b>16</b>

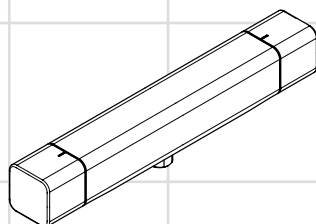

**Ecostat E**  
15786000  
(RSK: 8362139)

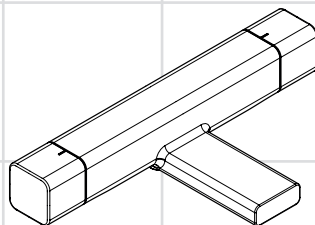

**Ecostat E**  
15794000  
(RSK: 8351323)



## Safety Notes

- △ Gloves should be worn during installation to prevent crushing and cutting injuries.
- △ The shower system may only be used for bathing, hygienic and body cleaning purposes.

## Installation Instructions

- Prior to installation, inspect the product for transport damages. After it has been installed, no transport or surface damage will be honoured.
- The product is not designed to be used with steam baths!
- The mixer must be installed, flushed and tested!

## Assembly (see page 6)

## Pressure and permeability test

- The connections of the thermostatic mixer should be tested regular after installation.

## Technical Data

Operating pressure:	max. 1 MPa
Recommended operating pressure:	0,1 - 0,5 MPa
Test pressure:	1,6 MPa
	(1 MPa = 10 bar = 147 PSI)
Hot water temperature:	max. 70 °C
Recommended hot water temp.:	65 °C
Centre distance:	160 mm
Connections M 26x1,5:	cold right - hot left
Thermal disinfection:	max. 70 °C / 4 min

- Safety against backflow
- The product is exclusively designed for drinking water!

## Symbol description



Do not use silicone containing acetic acid!

max.  
≈ 42 °C

## Safety Function (see page 8)

The desired maximum temperature for example max. 42 °C can be pre-set thanks to the safety function.



## Adjustment (see page 7)

After the installation, the output temperature of the thermostat must be checked. A correction is necessary if the temperature measured at the output differs from the temperature set on the thermostat.



## Maintenance (see page 9)

- △ To guarantee the smooth running of the thermostat, it is necessary from time to time to turn the thermostat from total hot to total cold.
- △ The mixer is equipped with non return valves. The non return valves must be checked regularly according to DIN EN 1717 in accordance with national or regional regulations (at least once a year).



## Dimensions (see page 13)



## Flow diagram (see page 13)

- ① Shower
- ② Bath tub



## Spare parts (see page 14)



## Cleaning (see page 16)



## Operation (see page 11)



## Troubleshooting

<b>Fault</b>	<b>Cause</b>	<b>Remedy</b>
Insufficient water	- Supply pressure inadequate	- Check water pressure (If a pump has been installed check to see if the pump is working).
	- Filters are dirty (97367000)	- Clean filter in front of the mixer and on the MTC-thermo cartridge (97367000)
	- Shower filter seal dirty	- Clean filter seal between shower and hose
Crossflow, hot water being forced into cold water pipe, or vice versa, when mixer is closed	- Backflow preventers dirty or leaking	- Clean backflow preventers, exchange if necessary
Spout temperature does not correspond with temperature set	- Thermostat has not been adjusted	- Adjust thermostat
	- Hot water temperature too low	- Increase hot water temperature to 42 °C to 65 °C
Temperature regulation not possible	- thermo cartridge calcified	- Exchange thermo cartridge
Shower or spout dripping	- Dirt or sedimentation on valve seat, shut-off unit damaged	- Clean or exchange shut-off unit



## Säkerhetsanvisningar

- △ Handskar skall bäras under monteringsarbetet så att kläm- och skärskador undviks.
- △ Produkten får bara användas till kroppshygien med bad och dusch.

## Monteringsanvisningar

- Det måste undersökas om produkten har transportskador innan den monteras. Efter monteringen accepteras inga transport- eller ytskiktsskador.
- Produkten är inte avsedd att användas tillsammans med ett ångbad!
- Armaturen måste installeras, genomspolas och testas.

## Montering (se sidan 6)

## Tryck och täthetsprov

- Termostatblandarens anslutningar skall täthetkontrolleras efter installationen.

## Tekniska data

Driftstryck:	max. 1 MPa
Rek. driftstryck:	0,1 - 0,5 MPa
Tryck vid provtryckning:	1,6 MPa
	(1 MPa = 10 bar = 147 PSI)
Varmvattentemperatur:	max. 70 °C
Rek. varmvattentemp.:	65 °C
Anslutningsmått:	160 mm
Anslutningar M 26x1,5:	kallt höger - varmt vänster
Termisk desinfektion:	max. 70 °C / 4 min

- Självspärr mot återflöde
- Produkten är enbart avsedd för dricksvatten!

## Symbolförklaring



Använd inte silikon som innehåller ättiksyra!

max.  
≈ 42 °C

## Safety Function (se sidan 8)

Med hjälp av Safety Function kan du ställa in den önskade maximaltemperaturen till exempelvis 42 °C och så förhindra skällningsrisk för barn.



## Inställning av maxtemperatur (se sidan 7)

När monteringen är klar måste termostatens tömnings-temperatur kontrolleras. En justering är nödvändig om den uppmätta temperaturen vid tappningsstället avviker från den som är inställd på termostaten.



## Skötsel (se sidan 9)

- △ För att garantera att termostaten ej kalkar igen, ska den regelbundet, en gång per vecka, konditioneras. Det sker genom att man några gånger snabbt slås om temperaturen från hett till kallt och tillbaka.
- △ Termostaten är utrustad med backventiler. Backventilens funktion måste kontrolleras regelbundet enligt nationella eller regionala bestämmelser i enlighet med DIN EN 1717 (minst en gång per år).



## Måtten (se sidan 13)



## Flödesschema (se sidan 13)

- ① Dusch
- ② Kar



## Reservdelar (se sidan 14)



## Rengöring (se sidan 16)



## Hantering (se sidan 11)



## Felsökning

Störning	Orsak	Åtgärd
För lite vatten	- Vattentrycket är för lågt - Smutsfiltren är igensmutsade (97367000) - Silfiltret i duschen smutsigt	- Kontrollera ledningstryck - Rengör smutsfiltren vid inloppen och på termosensorn (97367000) - Rengör silfiltret mellan slangen och termostaten
Korsflöde – varmt vatten pressas vid avstängd ermostat in i kallvatten- inloppet, och vice versa	- Backventil är igensmutsad eller otät	- Rengör backventil, byt ut om nödvändigt
Den faktiska vatten- temperaturen stämmer inte överens med den inställda	- Termostaten ställdes inte in - Varmvattentemperaturen är för låg	- Justera termostaten - Höj varmvattentemperaturen till mellan 42°C och 65°C
Temperaturen kan ej ställas in	- Termosensorn är igenkalkad	- Byt termosensorn
Det droppar ur handdusch eller utloppspip till kar	- Smuts eller avlagringar på packningen, överdelen på avstängningsventilen är skadad	- Rengör eller byt överdelen av avstängningsventilen

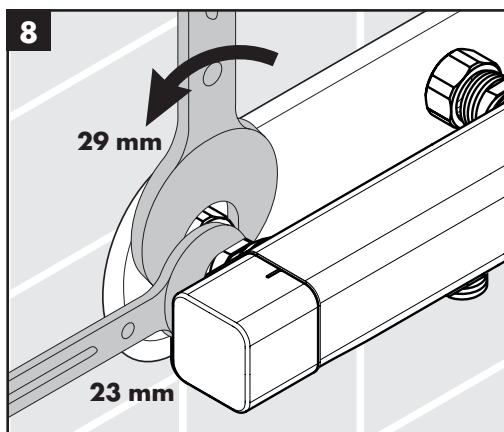
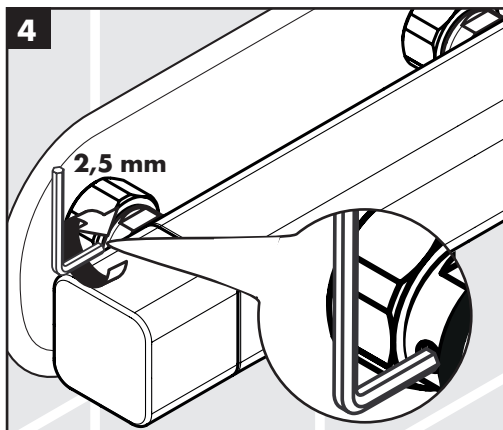
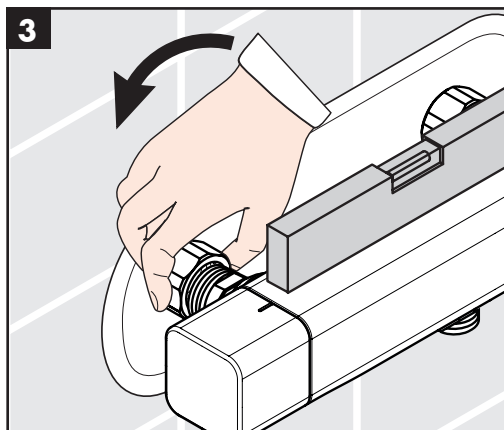
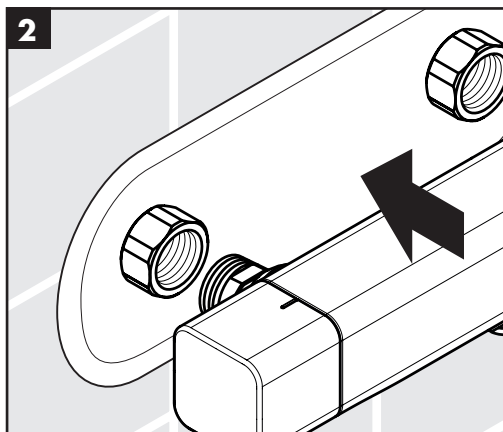
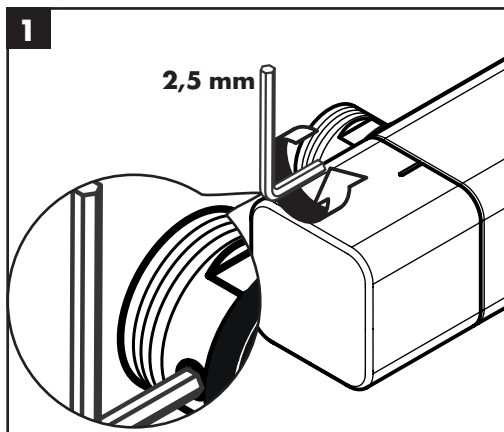

The nuts of the installation plate must be tightened to the manufacturer's instructions.

Muttrarna dras åt enligt monteringsanvisningen från leverantören av blandarfäste.

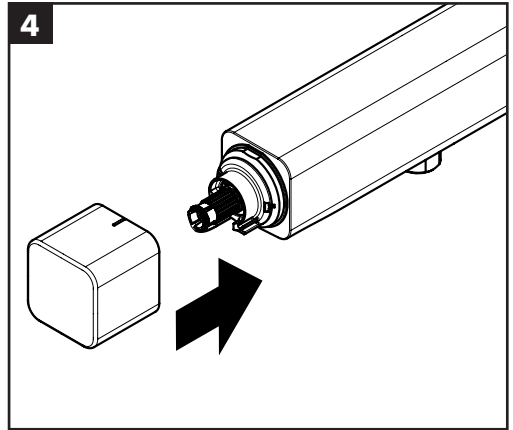
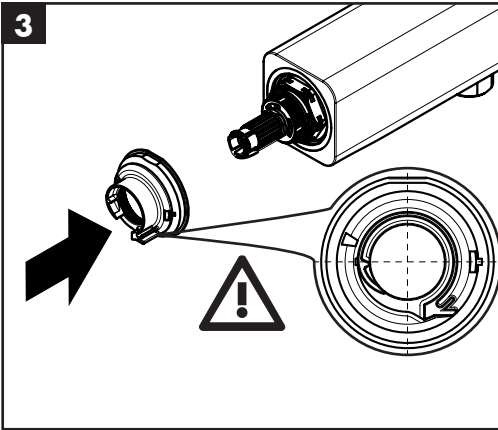
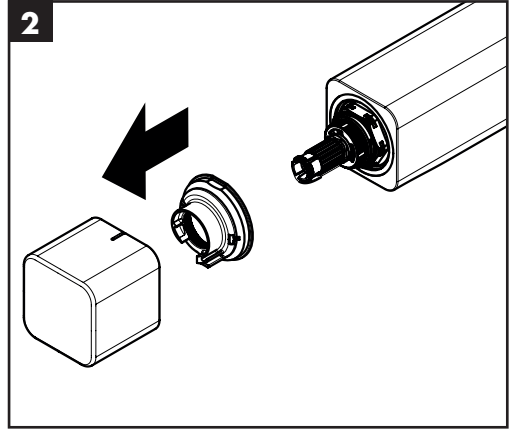
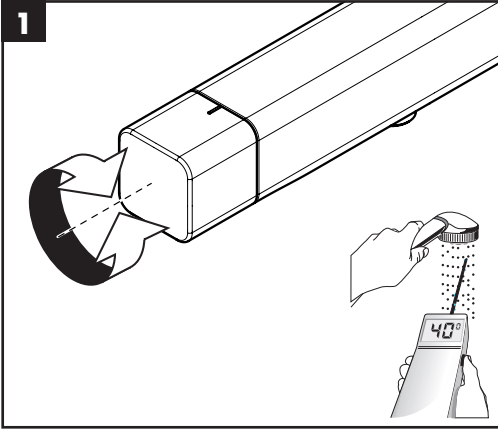

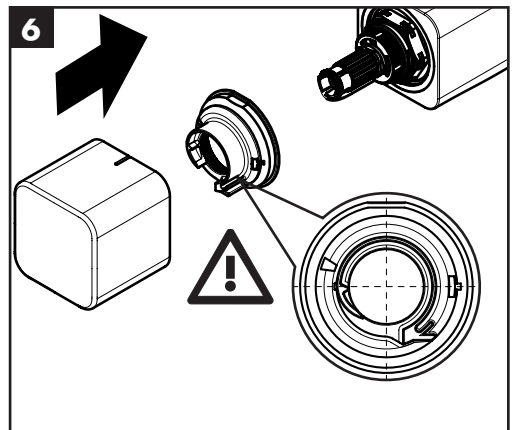
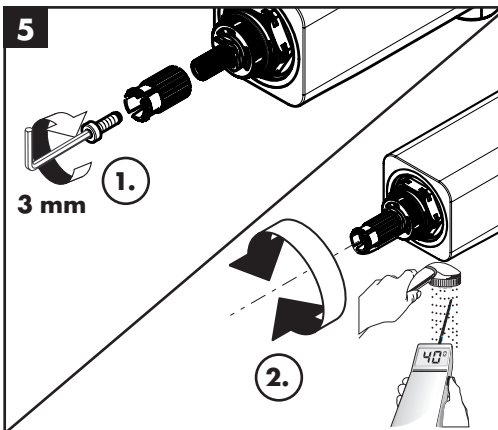
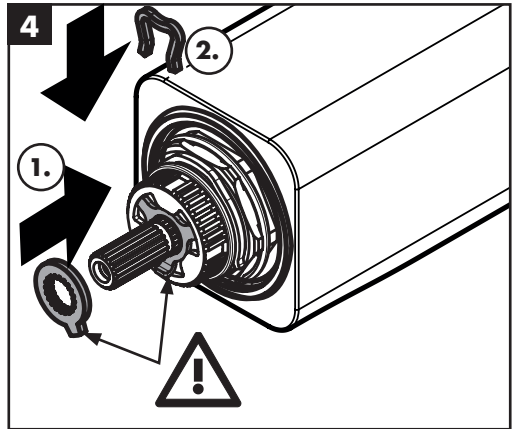
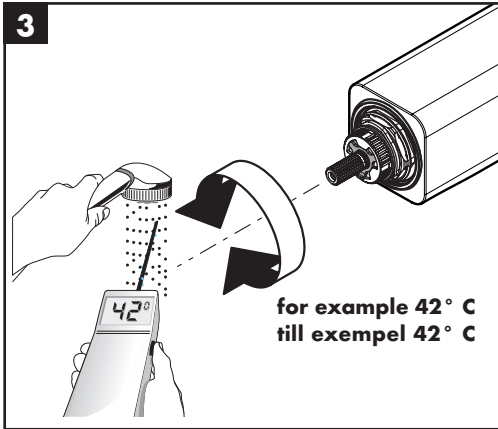
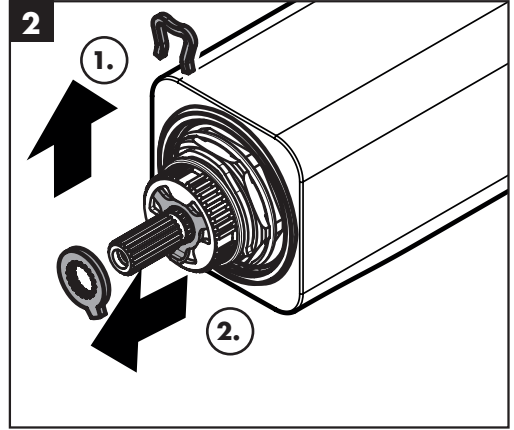
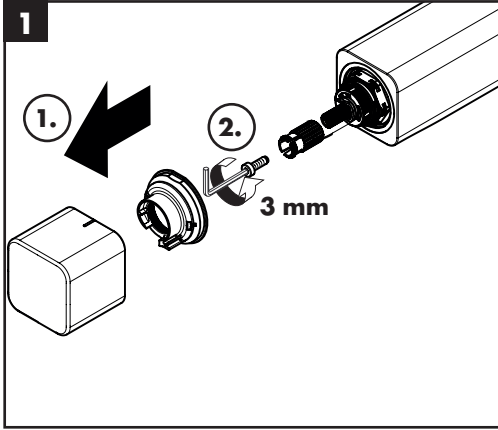



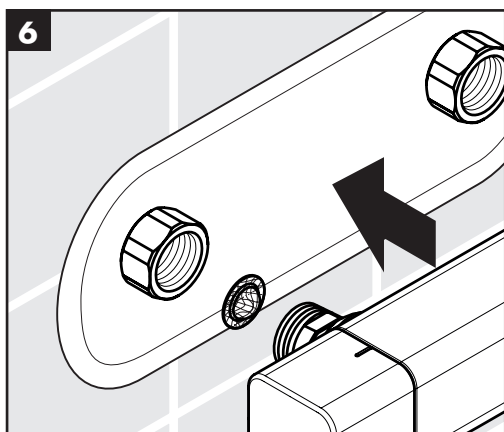
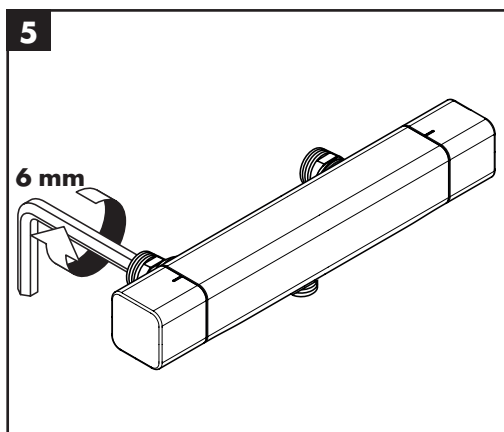
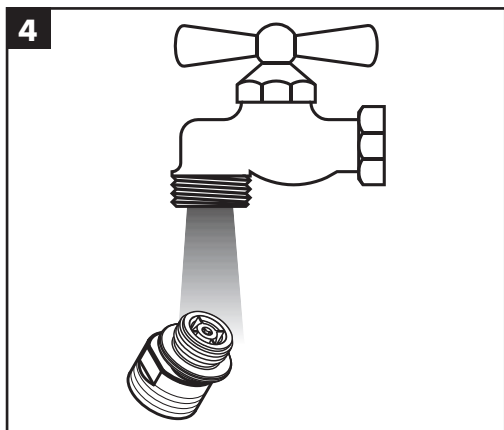
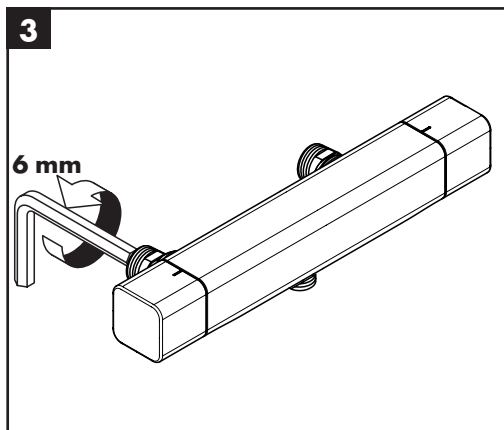
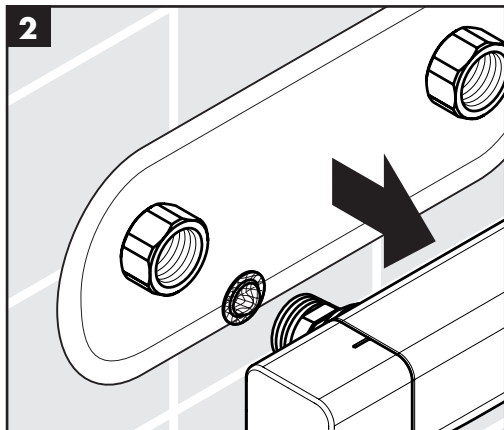
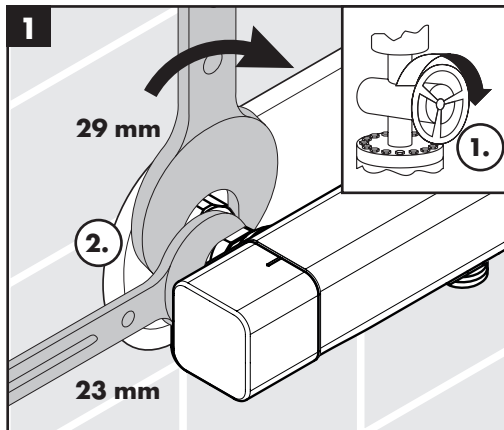

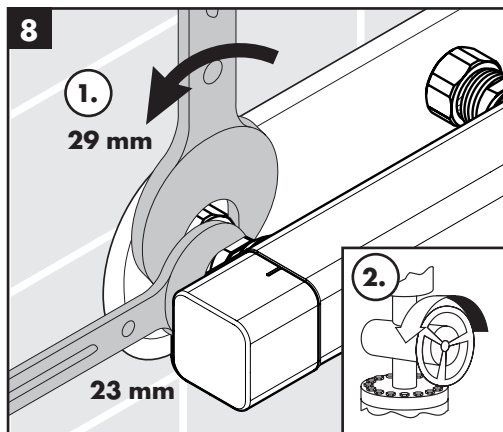
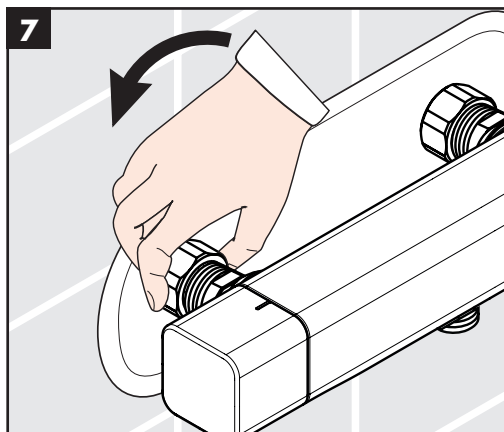

**The nuts of the installation plate must be tightened to the manufacturer's instructions.**

**Muttrarna dras åt enligt monteringsanvisningen från leverantören av blandarfäste.**

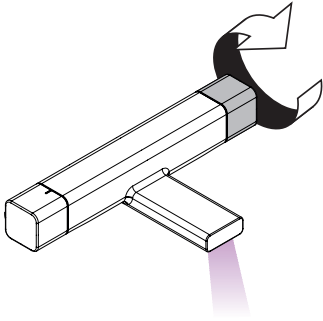

open / öppna

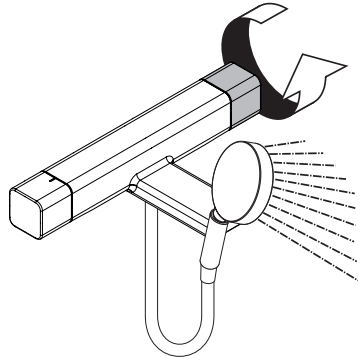

open / öppna

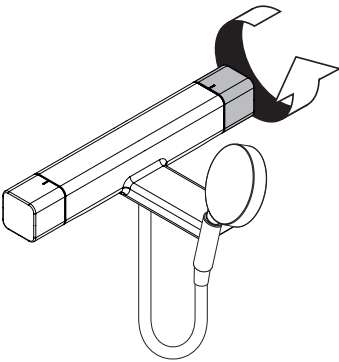

close / stänga

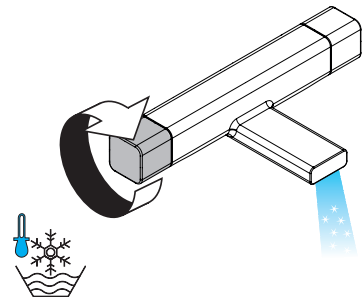

cold / kallt

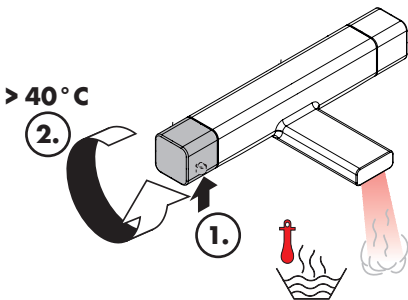

hot / varmt

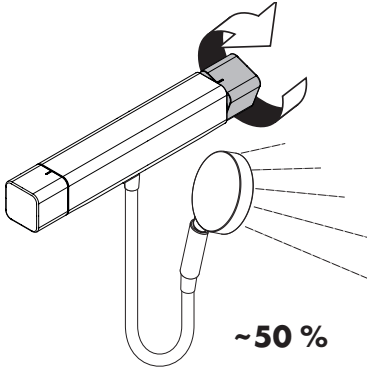

open / öppna

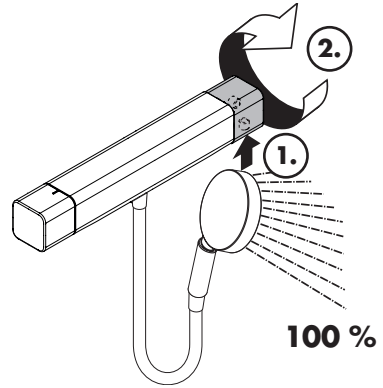

open / öppna

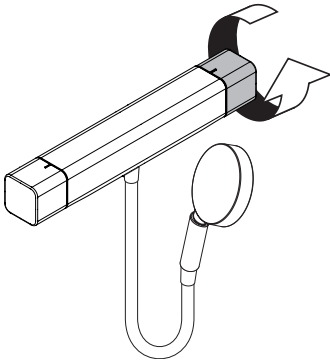

close / stänga

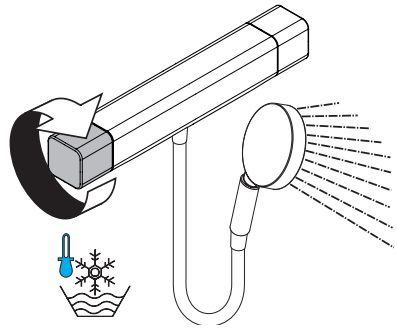

cold / kallt

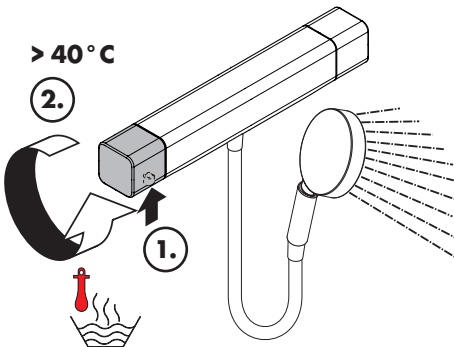

hot / varmt



**Ecostat E**  
15794000

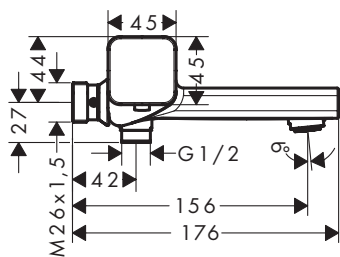

**Ecostat E**  
15786000

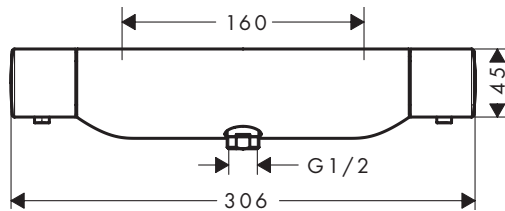
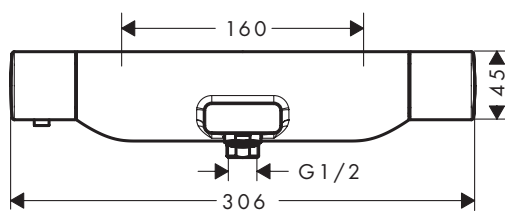
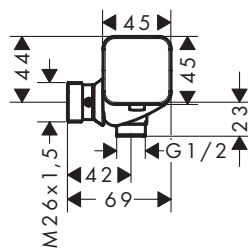

**Ecostat E**  
15794000

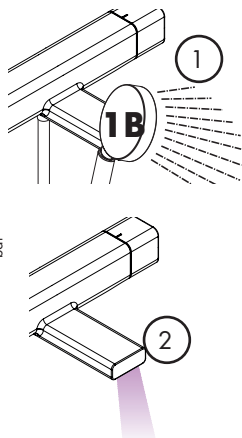
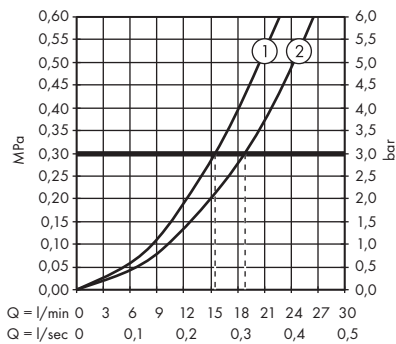

**Ecostat E**  
15786000

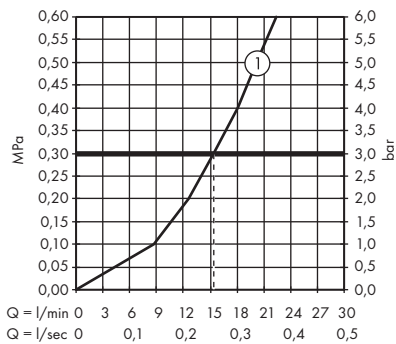



**Ecostat E**  
15794000

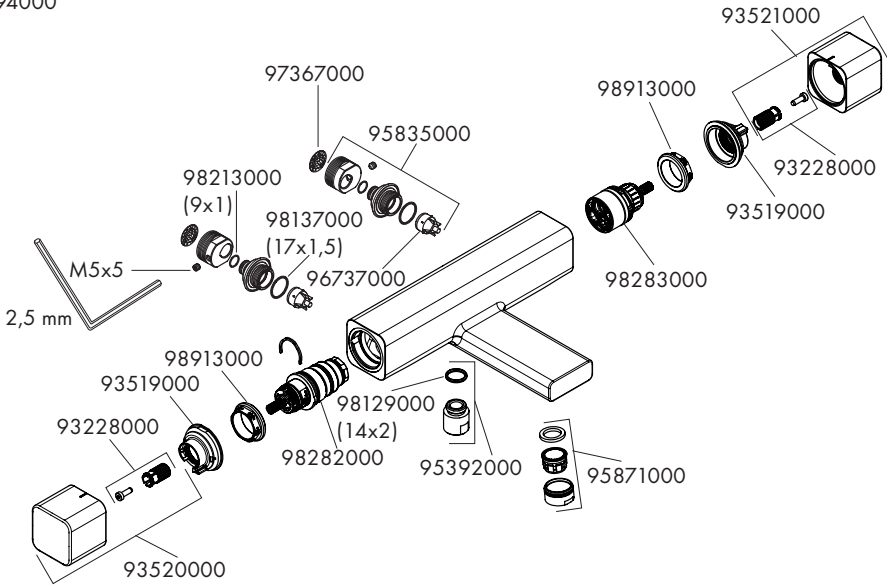

**Ecostat E**  
15786000

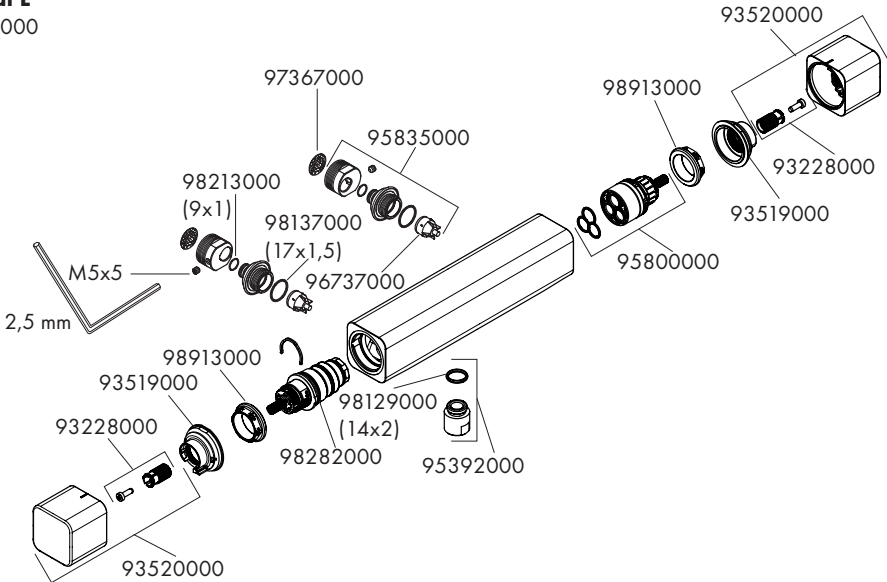





**EN** Cleaning recommendation / Warranty / Contact

**SV** Rengöringsrekommendationer / Garanti / Contacto



[www.hansgrohe.com/  
cleaning-recommendation](http://www.hansgrohe.com/cleaning-recommendation)

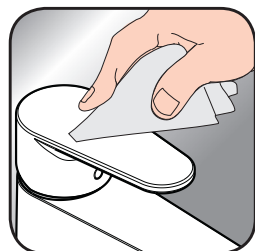

[www.hansgrohe.com/  
cleaning-recommendation](http://www.hansgrohe.com/cleaning-recommendation)



[www.hansgrohe.com/  
cleaning-recommendation](http://www.hansgrohe.com/cleaning-recommendation)



[www.hansgrohe.com/  
cleaning-recommendation](http://www.hansgrohe.com/cleaning-recommendation)