

Self Forming Screw FLS F

Group: A430

Application

The Self Forming Screw FLS creates its own thread inside the wall of the siFramo pilot hole. During the screw-driving operation, the base steel is re-shaped and hardened to form an air-tight seal between the threads of the screw and the surrounding steel, making it exceptionally resistant to vibrational loosening and increasing fastening strength.

Technical Data

Application	Tightening torque [Nm]
System siFramo	60
Connection to Channels MS 41	35

Material: Steel, HCP

Approvals / Compliance

MPA tested

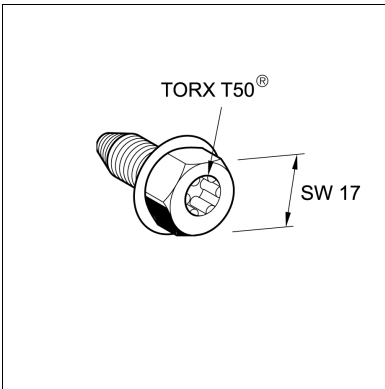

Type	W [kg]	Quantity [pack]	Part number
FLS F	0.03	100	192512