

SPIROTECH SPECIFICATION SHEET



Product:	SpiroTrap Rp 1 1/4"	Universal Threated fitting
Customer:	customer	
Project:	project	
Reference:	reference	

Type:	UE125WJ
Date:	pilot not final

Design criteria	
Medium:	Water / glycol (max 50%)
Max. flow velocity:	1 m/s
Max. flow rate:	1.00 l/s
Max. pressure:	10 bar-g
Max. temperature:	110 °C
Design standard:	EN 13445

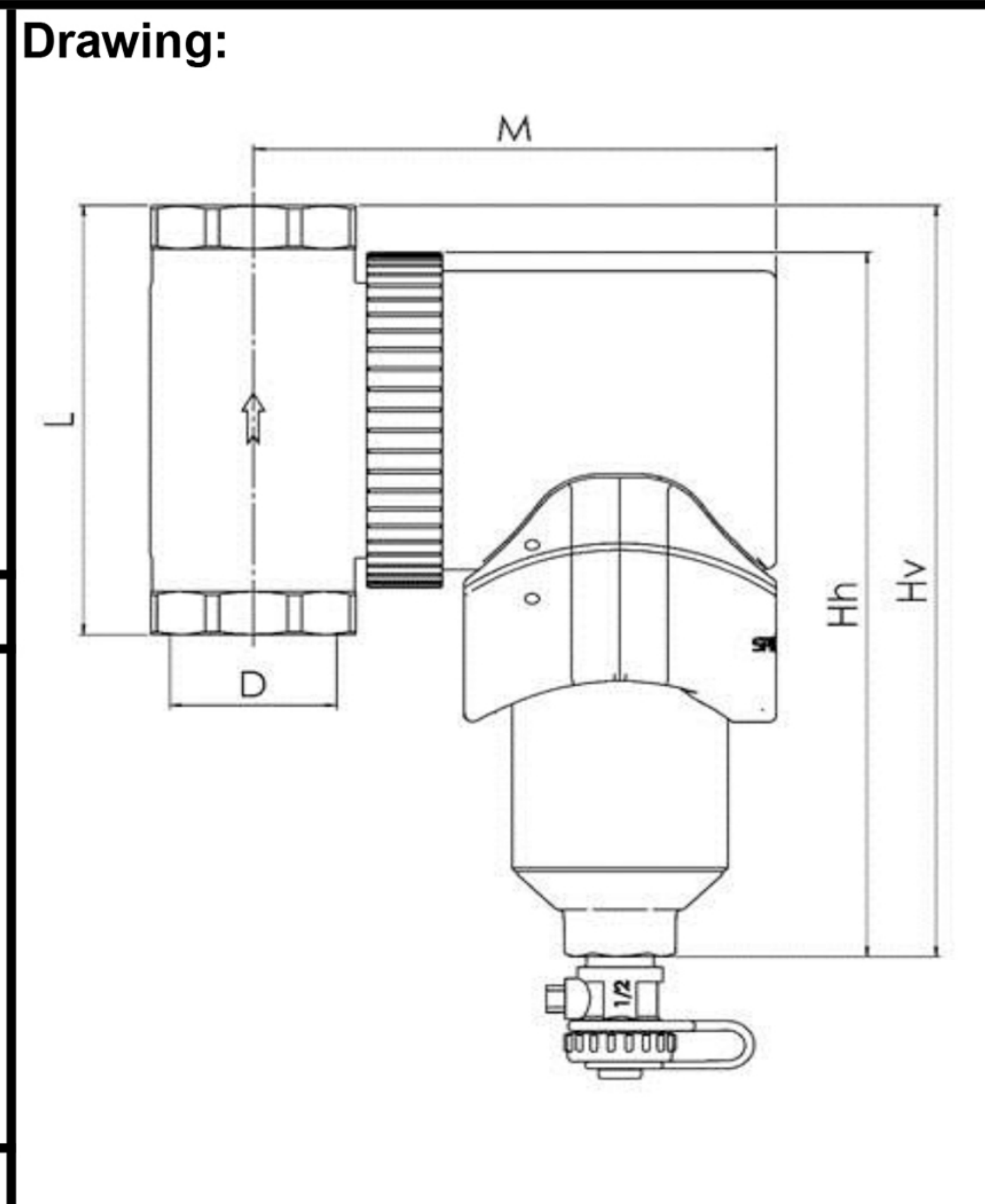

Testing and quality assurance	
Leakage test:	no
Test certificate:	no
Design and manufacturing acc. 97/23/EC:	yes
Material certificates (structural parts):	no
Drawing:	no

Construction materials	
Body:	Brass
Swivel	Brass
Drain valve:	Brass
Spirotube	Tube: Copper
	Wire: Copper
	Solder: Tin(SnCu3)
Magnet	Neodymium

Dimensions:		
D	Rp 1 1/4"	
Hv	224	mm
Hh	210	mm
L	128	mm
M	138	mm
Volume:	0.75	ltr
Dry weight (approx):	3.57	kg

Subject to changes