



Auxiliary Products

FVF

Description

FVF strainer is designed for heating, district heating and cooling systems.

Strainer removes and retains foreign particles like welding beads, swarf, sand, etc. carried along by heating / cooling medium.

Strainer is installed to protect sensitive equipment like meters, pumps, control valves against danger caused by foreign particles and in wide range of other applications.

Furthermore, strainer is available with a plug, magnetic insert or ball valve. Combination with ball valve allowing a quick and efficient cleaning.

Main data:

- DN 15- (125) 200
- PN 16/25
- Temperature:
 - Circulation water / water with glycol:
 - 10 ... 150 °C (PN 16), -20 ... 150 °C (PN 25)
- Connections:
 - flange (strainer) DIN EN 1092-2
 - thread (ball valve)

Features & benefits

- Available with plug, magnetic insert, or quick-clean ball valve for easy maintenance
- Wide size and pressure range: DN 15–200, PN 16/25, -20...150 °C
- Removes debris (welding beads, swarf, sand) to protect pumps, valves, and meters
- Improves system reliability, extends equipment lifespan, and reduces downtime

Ordering

Product code numbers

Flange¹⁾ strainer FVF

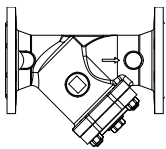
Picture	DN (mm)	k _{vs} ²⁾ (m ³ /h)	T _{max}	Code No.	T _{max}	Code No.	T _{max}	Code No.
			PN 16 with draining ball valve		PN 16		PN 25	
	15	5.3	150 °C ³⁾	065B7726	150 °C	065B7740	150 °C	065B7770
	20	9.5		065B7727		065B7741		065B7771
	25	16.5		065B7728		065B7742		065B7772
	32	20		065B7729		065B7743		065B7773
	40	33		065B7730		065B7744		065B7774
	50	54		065B7731		065B7745		065B7775
	65	95		065B7732		065B7746		065B7776
	80	140		065B7733		065B7747		065B7777
	100	201		065B7734		065B7748		065B7778
	125	350		065B7735		065B7749		065B7779
	150	542		065B7736		065B7750		-
	200	870		065B7737		065B7751		-

¹⁾ Flanges acc. to EN 1092-2 (PN 16 and PN 25 respectively)

²⁾ For strainers with normal screens

³⁾ To prevent scalds during draining the draining ball valve must be equipped with drain hose, that leads to drainage system

Flange¹⁾ strainer FVF, I-pack

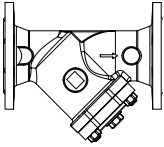
Picture	DN (mm)	kvs ²⁾ (m ³ /h)	Tmax	Code No.
			PN 16 with draining ball valve	
	15	5.3	150 °C ³⁾	065B7726
	20	9.5		065B7727
	25	16.5		065B7728
	32	20		065B7729
	40	33		065B7730
	50	54		065B7731
	65	95		065B7732
	80	140		065B7733
	100	201		065B7734
	125	350		065B7735
	150	542		065B7736
	200	870		065B7737

¹⁾ Flanges acc. to EN 1092-2 (PN 16)

²⁾ For strainers with special screens with mesh size 0.40 mm (280 meshes/cm²). Special screen is not available as a spare part.

³⁾ To prevent scalds during draining the draining ball valve must be equipped with drain hose, that leads to drainage system

Accessories code numbers

FVF-M magnetic insert¹⁾

Picture	DN (mm)	Code No.
	15	065B7790
	20	
	25	065B7791
	32	
	40	065B7792
	50	065B7793
	65	065B7794
	80	065B7795
	100	065B7796
	125	
	150	065B7797
	200	065B7798

¹⁾ FVF-M magnetic inserts can be mounted in FVF strainers which are mentioned as "PN 16" and "PN 25" in the table "Flange¹⁾ strainer FVF".

FVF-B ball valve²⁾

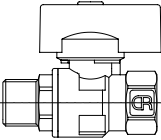
Picture	DN (mm)	T _{max} (°C)	Code No.
	10 (used for FVF DN 15-50)	150	065B7802
	15 (used for FVF DN 65-200)		065B7801

²⁾ FVF-B ball valve can be mounted only on "PN 16 with draining ball valve" - see codes in the table "Flange¹⁾ strainer FVF"

Spare parts code numbers

FVF-Screen *

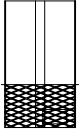
Picture	DN (mm)	PN (bar)	Code No.	
			(normal)	(fine)
	15/20	16, 20	065B7810	065B7824
	25		065B7812	065B7826
	32		065B7813	065B7827
	40		065B7814	065B7828
	50		065B7815	065B7829
	65		065B7816	065B7830
	80		065B7817	065B7831
	100		065B7818	065B7832
	125		065B7819	065B7833
	150		065B7820	065B7834
	200		065B7821	065B7835

FVF-Gasket

Picture	DN (mm)	Code No.
	15/20	065B7886
	25/32	065B7887
	40	065B7888
	50	065B7889
	65	065B7890
	80	065B7891
	100	065B7892
	125	065B7893
	150	065B7894
	200	065B7895

* Each FVF screen or magnetic insert is supplied together with a gasket.

Product details

General data

Nominal diameter		DN	15	20	25	32	40	50	65	80	100	125	150	200
k _{VS} value	normal screen	m ³ /h	5.3	9.5	16.5	20	33	54	95	140	201	350	542	870
	fine screen		5.0	9.0	14.8	18	30	48	85	131	189	320	494	818
k _{VS} value (with magnetic insert)	normal screen	m ³ /h	4.8	8.6	14.9	18	29	49	86	127	183	316	489	809
	Mesh size		4.5	8.1	13.3	16	27	44	77	119	170	297	459	760
Mesh size	normal screen	mm	0.54		0.87					1.18				
	fine screen		0.25											
Number of meshes	normal screen	n/cm ²	150		64					25				
	fine screen		625											
Flow medium	Circulation water / glycolic water up to 50%													
Nominal pressure	PN	16 or 25												
Medium temperature	°C	-10 ... 150 (PN 16), -20 ... 150 (PN 25)												
Connection	Flanges acc. to DIN EN 1092-2 (PN 16 and PN 25 respectively)													
Materials														
Body (strainer)	PN 16	Grey cast iron EN-GJL-250 (GG-25)												
	PN 25	Ductile iron EN-GJS-400-18-LT (GGG 40.3)												
Body (ball valve)	Dezincing free brass CuZn36Pb2As													
Screen	Stainless steel, mat. No 1.4301													
Gasket	Graphite													

Design

- 1. Body
- 2. Cover
- 3. Screen
- 4. Gasket
- 5. Screw
- 6. Nut
- 7. Plug screw
- 8. Magnet
- 9. Washer
- 10. Handle
- 11. Ball
- 12. Stem

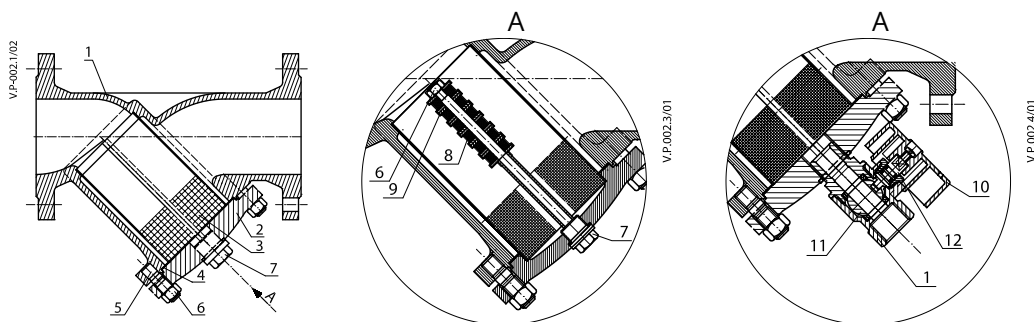

Pressure and temperature data

Pressure temperature diagram

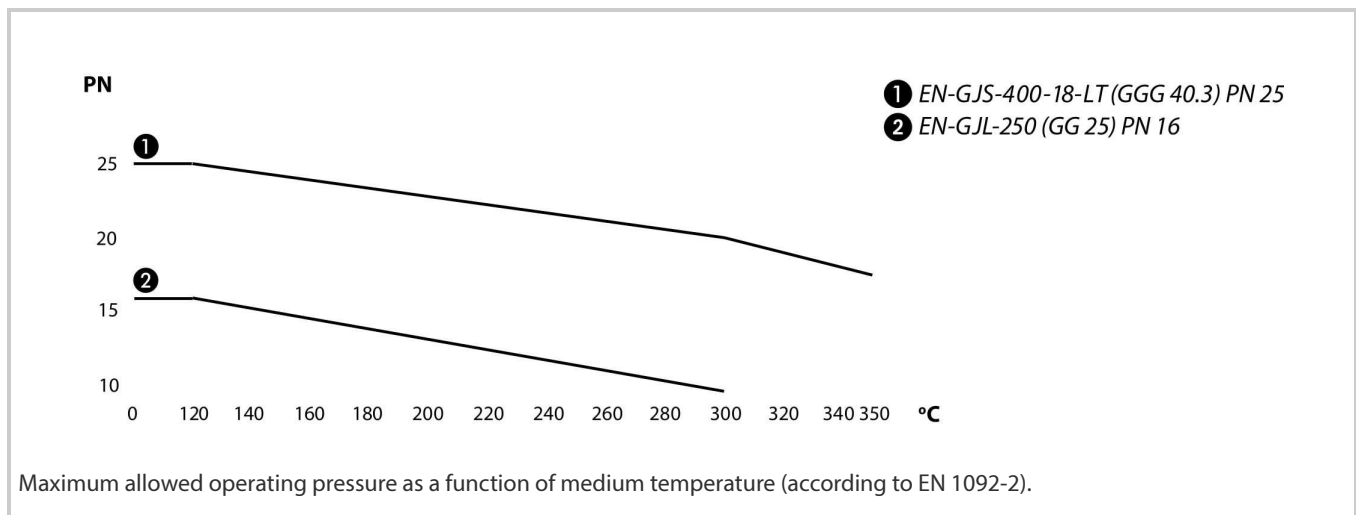

Note: Danfoss uses environment friendly paint which may crack at temperatures above 150 °C.

Performance and environmental conditions

Flow diagram

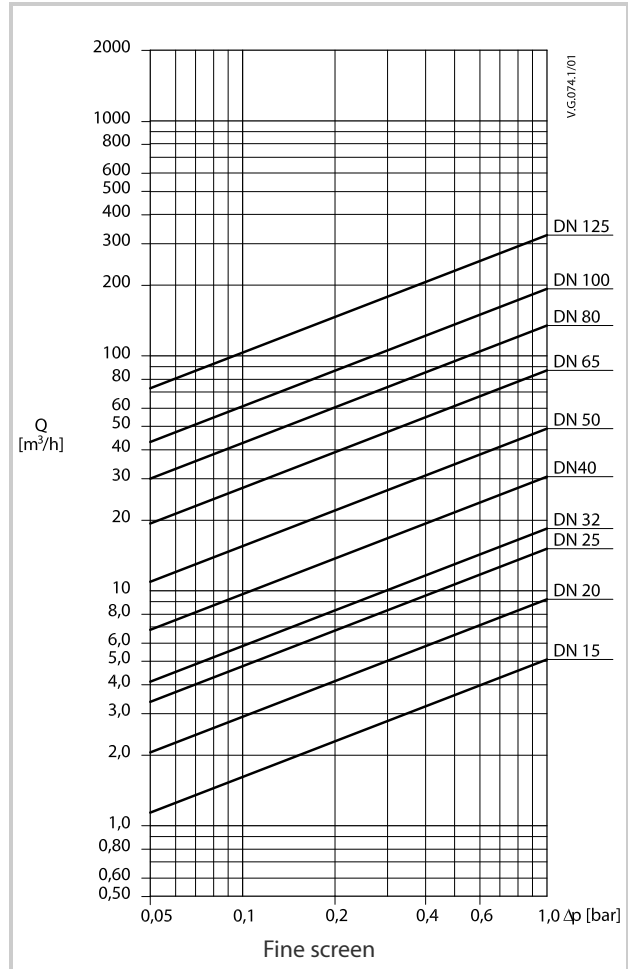
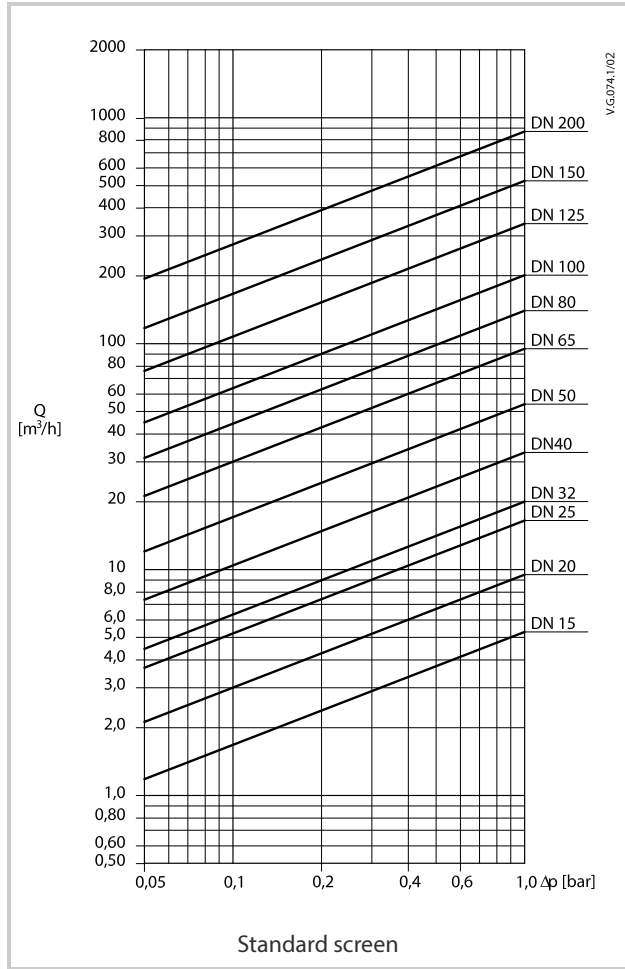

Dimensions

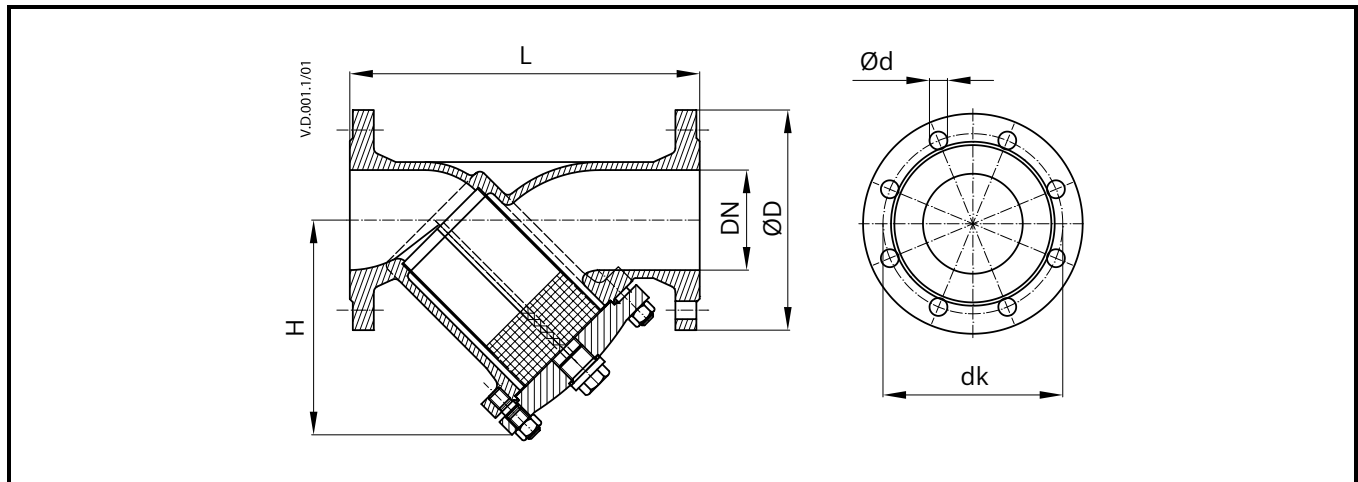

DN	L	H	PN 16			PN 25			Weight (kg)
			ØD	Ød	dk	ØD	d	dk	
			mm						
15	130	75	95	14	65	95	14	65	2.2
20	150	75	105	14	75	105	14	75	3.3
25	160	90	115	14	85	115	14	85	3.8
32	180	90	140	19	100	140	19	100	5.0
40	200	110	150	19	110	150	19	110	6.5
50	230	120	165	19	125	165	19	125	8.5
65	290	140	185	19	150	185	19	145	12.0
80	310	165	200	19	160	200	19	160	16.6
100	350	220	220	19	180	235	23	190	20.0
125	400	260	250	19	200	270	28	220	39.0
150	480	300	285	23	240	-	-	-	61.0
200	600	360	340	23	295	-	-	-	109

Ball valve

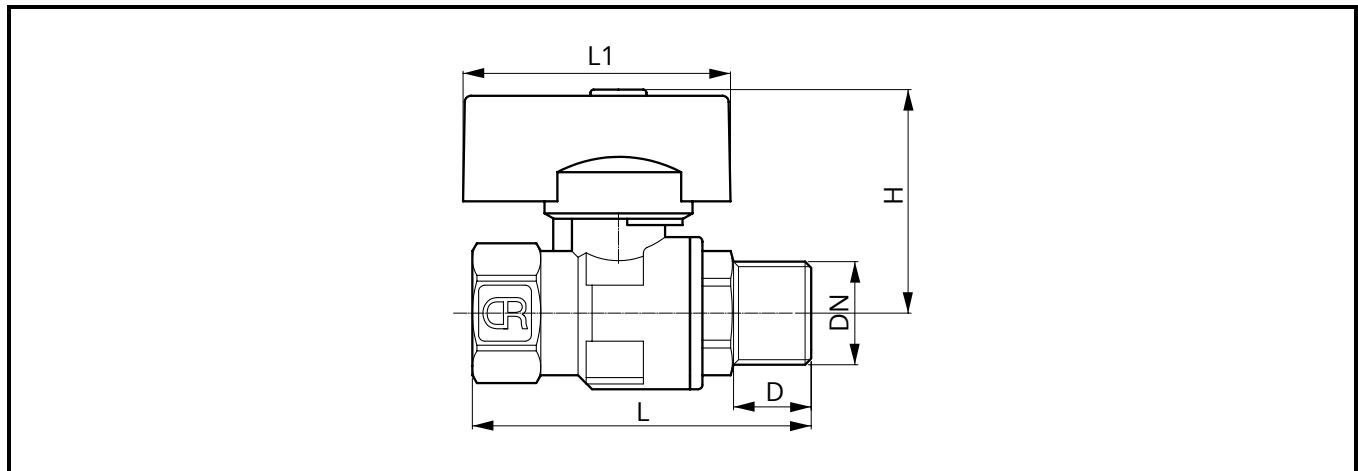

DN	For strainers DN	L	L1	H	D
		mm			
10	15 - 50	52	43	36	10
15	65 - 200	69	50	52	17.5

Installation

Installation positions

The medium flow direction must correspond to an arrow on the strainer body.

Strainers are to be installed in horizontal position with mesh bonnet directed downwards. Vertical position is also allowed (be aware - when medium flows upwards strainer retains all foreign particles but is not able to collect them).

Sufficient space to pull out the mesh for replacement and cleaning must be ensured.

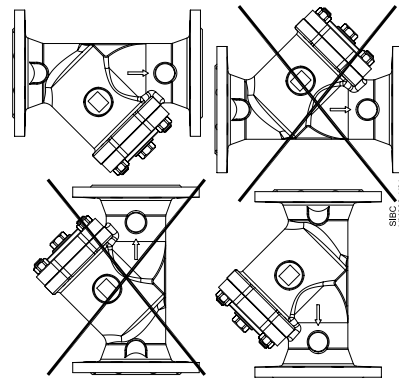

Certificates, declarations and approvals

The list contains all certificates, declarations, and approvals for this product type. Individual code number may have some or all of these approvals, and certain local approvals may not appear on the list.

When you click on the link you will be directed to the latest version of the 'Declaration of Conformity'. Products developed and sold before this date of issue conform to the directives/standards in force at the time of their sale.

Approval type	Title	Certification body	Approval topic
EU Declaration	Danfoss EU BF273686516767en-001001.07	Danfoss	PED
Pressure Safety Certificate	LLC CDC EURO-TYSK UA.TR.089.1011.03-22	LLC CDC EURO TYSK - Ukraine	PED
UA Declaration	Danfoss UA 2023-01- 10_Heating.Filters.PL08	Danfoss	PED
Export Control Declaration	Strainers	Danfoss	
Pressure Safety Certificate	CE-0062-PED-H-DAF 002-24- DNK-rev-A	BV - Bureau Veritas	PED

Contact details

Online support

Danfoss offers a wide range of support along with our products, including digital information, software, mobile apps and expert guidance. See the possibilities below.



The Danfoss Design center

Discover the Design Center, our advanced digital platform that streamlines product selection. With integrated tools and enhanced type pages, it's simpler than ever to access product information and documentation, and to select the right products. Check the availability of Danfoss products at partner locations and enjoy seamless transitions from selection to purchase with our basket-to-basket functionality. Whether you're buying from our distributors or directly from the Product Store, the Design Center simplifies your experience. Learn more at: designcenter.danfoss.com.



The Danfoss product store

The Danfoss Product Store is a one-stop shop available 24/7 for our customers, no matter where you are in the world or what area of industry you work in. Browse our catalog, check product details and documentation, view your prices and product availability, and quickly finalize your purchase. Start browsing at: store.danfoss.com.



Danfoss Partner Portal/Product Data tool

Designed to support you with easy access to product data extracts, essential resources, tools, and information. The Partner Portal provides a centralized hub for product documentation, training materials, marketing assets, and technical support, ensuring you have everything you need to succeed and grow your business with Danfoss. The Partner Portal is available 24/7 at: partner.danfoss.com and is ready to support your business.



Find technical documentation

Find technical documentation you need to get your project up running. Get direct access to our official collection of data sheets, certificates and declarations, manuals and guides, 3D models and drawings, case stories, brochures, and much more. Start searching now at: documentation.danfoss.com.



Danfoss Learning

Danfoss Learning is a free online learning platform. It features courses and materials specifically designed to help engineers, installers, service technicians, and wholesalers better understand the products, applications industry topics, and trends that will help you do your job better. Find your local Danfoss website here: learning.danfoss.com.



Get local information and support

Local Danfoss websites are the main sources for help and information about our company and products. Find product availability, get the latest regional news, or connect with a nearby expert - all in your own language. Find your local Danfoss website here: danfoss.com.

Danfoss A/S

Climate Solutions . danfoss.com . +45 7488 2222

Any information, including, but not limited to information on selection of product, its application or use, product design, weight, dimensions, capacity or any other technical data in product manuals, catalogues description, advertisements, etc. and whether made available in writing, orally, electronically, online or via download, shall be considered informative, and is only binding if and to the extent, explicit reference is made in a quotation or order confirmation. Danfoss cannot accept any responsibility for possible errors in catalogues, brochures, videos and other material. Danfoss reserves the right to alter its products without notice. This also applies to products ordered but not delivered provided that such alterations can be made without changes to form, fit or function of the products. All trademarks in this material are property of Danfoss A/S or Danfoss group companies. Danfoss and the Danfoss logo are trademarks of Danfoss A/S. All rights reserved.
