

Data sheet

Standard JIP™ ball valves (PN 16, 25, 40)

Description



Danfoss Standard JIP™ ball valves is a range of reduced bore shut off valves developed for District Heating and District Cooling networks, with circulating medium.

It is a range of steel ball valves with fully welded body.

The valve design makes them ideal for building installation due to:

- Energy saving: with optimum flow design valves have highest kv on the market and consequently lowest pump energy costs.
- Long lifetime and optimal tightness due to design and material selection in ball seal and stem seal (carbon reinforced PTFE) ;
- The valves are maintenance free, besides the shut off valves in the core distribution network Danfoss offers a range of supplementary valves, e.g. hot tap valves, branching valves, twin valves and draining valves.

Main data:

- DN 15-600
- $k_{vs} = 11-26.300 \text{ m}^3/\text{h}$
- PN 16 / 25 / 40
- Leakage rate A (according to EN12266-1) - both directions
- Temperature: 0 ... 180 °C
- Medium: Circulation water / glycolic water up to 50 %
- Min. storage and transport temperature: -40 °C

Approvals and norms:

- 100 % final inspection. Leak and shell test as well as dimension and functionality test is performed on each and every valve according to applicable standard (EN 12266 part 1 P10-P11-P12 & part 2 F20).
- PED Directive 2014/68/EU Modul H1
- Danfoss A/S is certified according to ISO 9001
- Furthermore certified according to ISO 14001 and OHSAS 18001.

Ordering

JIP-WW welding
JIP-FF flange

JIP-WW welding			JIP-FF flange			
Code No.						
DN (mm)	WW PN 25	WW PN 40	DN (mm)	FF PN 16	FF PN 25	FF PN 40
15	-	065N1100	15	-	-	065N1101
20		065N0105	20			065N0305
25		065N0110	25			065N0310
32		065N0115	32			065N0315
40		065N0120	40			065N0320
50		065N0125	50			065N0325
65	065N4280	-	65	065N4282	065N4281	-
80	065N4285		80	065N4287	065N4286	
100	065N0140		100	065N0240	065N0340	
125	065N0745		125	065N0845	065N0945	
150	065N0750		150	065N0850	065N0950	
200	065N0755		200	065N0855	065N0955	

JIP-WW welding			JIP-FF flange			
DN (mm)	Code No. WW PN 25		Code No. FF PN 16		Code No. FF PN 25	
	Valve with worm gear	Valve with gear flange	Valve with worm gear	Valve with gear flange	Valve with worm gear	Valve with gear flange
65	065N0134	065N0132	065N0223	065N0232	065N0331	065N0332
80	065N0139	065N0137	065N0236	065N0237	065N0336	065N0337
100	065N0144	065N0142	065N0243	065N0242	065N0341	065N0342
125	065N0146	065N0147	065N0246	065N0247	065N0346	065N0347
150	065N0151	065N0152	065N0251	065N0252	065N0351	065N0352
200	065N0156	065N0157	065N0275	065N0257	065N0356	065N0357
250	065N0161	065N0162	065N0216	065N0262	065N0361	065N0362
300	065N0166	065N0167	065N0266	065N0267	065N0366	065N0367
350	065N0171	065N0172	065N0271	065N0272	065N0371	065N0372
400	065N0176	065N0177	065N0276	065N0277	065N0376	065N0377
450	065N0178	065N0179	065N0278	065N0279	065N0378	065N0379
500	065N0181	065N0182	065N0281	065N0282	065N0381	065N0382
600	065N0186	065N0187	-			

JIP-II internal thread
JIP-IW internal thread/welding

JIP-II internal thread			JIP-IW internal thread / welding		
DN (mm)	Code No. II PN 40		DN (mm)	Code No. IW PN 40	
	L-handle high stem	T-handle low stem		L-handle high stem	T-handle low stem
15	065N0800	065N0802	15	065N0900	065N0904
20	065N0805	065N0807	20	065N0905	065N0908
25	065N0810	065N0812	25	065N0910	065N0914
32	065N0815	-	32	065N0915	-
40	065N0820		40	065N0920	
50	065N0825		50	065N0925	

Ordering

JIP-FW flange/welding

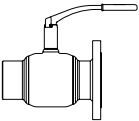
			
JIP-FW flange / welding			
DN (mm)	Code No.		
	PN 16	PN 25	PN 40
15			065N1102
20			065N0705
25			065N0710
32			065N0715
40			065N0720
50			065N0725
65	065N4284	065N4283	
80	065N4289	065N4288	
100	065N0540	065N0640	
125	065N0960	065N0975	
150	065N0965	065N0980	
200	065N0970	065N0985	

Copper valves

JIP-CC copper

JIP-IC internal thread /copper

Max temp. 130°

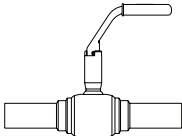
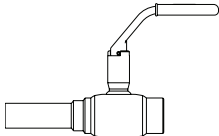
			
JIP-CC copper		JIP-IC internal thread / copper	
DN (mm)	Code No.		
	CC PN 16	IC PN 16	
15	065N4058	065N4057	
20	065N4067	065N4064	
25	065N4095	065N4087	

Copper twin valves for single pipe connection

JIP-IC internal thread / copper

Max temp. 130°

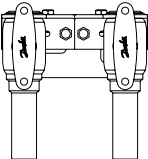
	
JIP-IC internal thread / copper	
DN (mm)	Code No.
	IC PN 16 with T-handle
15	065N4195
20	065N4071

Twin valves for single pipe connection

T-handle (DN 15-25) or

L-handle (DN 32)

JIP- WW welding

JIP-II internal thread

JIP IW internal thread / welding

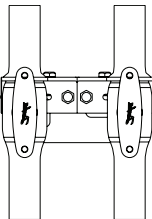
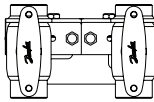
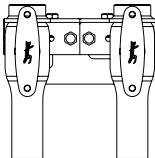
					
JIP-WW welding		JIP-II internal thread		JIP-IW internal thread / welding	
DN (mm)	Code No.				
	WW PN 40	II PN 40		IW PN 40	
15	065N4001	065N0801		065N0901	
20	065N4002	065N0806		065N0906	
25	065N4003	065N0811		065N0911	
32	065N4004	065N0816		065N0916	

Ordering

Twin valves for double pipe connection
T-handle
JIP-IW internal tread / welding
JIP-II internal thread

JIP-IW internal thread / welding		JIP-II internal thread	
DN (mm)	Code No.		
	IW PN 40	II PN 40	
15	065N7032	065N7022	
20	065N7034	065N7024	
25	065N7036	065N7026	

Draining valves

JIP-WE cc welding/external thread with closing cap

JIP-WE cc welding / external thread with closing cap			
DN (mm)	Code No.		
	WE PN 40-hex vers.	WE PN 40-L-handle	
15	065N4322	065N4422	
20	065N4323	065N4423	
25	065N4324	065N4424	
32	065N4325	-	
40	065N4326		
50	065N4327		

Actuators

DN (mm)	Code No.		
	Auma NORM	Auma MATIC	
65	065N8397	065N8398	
80	065N8199	065N8399	
100	065N8200	065N8400	
125-200	065N8205	065N8405	
250	065N8220	065N8420	
300-350	065N8225	065N8425	
400	065N8235	065N8435	
450-600	065N8240	065N8440	

Worm gear

Description	Worm gear	Position indicator with end switch
Worm gear for DN 65 reduced bore	065N0683	065N0694
Worm gear for DN 80-100 reduced bore	065N0684	065N0695
Worm gear for DN 125-200 reduced bore	065N0685	065N0695
Worm gear for DN 250 reduced bore	065N0691	065N0696
Worm gear for DN 300-350 reduced bore	065N0687	065N0697
Worm gear for DN 400 reduced bore	065N0688	065N0698
Worm gear for DN 450-600 reduced bore	065N0689	065N0699
Position indicator: Temperature -15 ... 80°C, IP65 Worm gear: Temperature -20 ... 120°C, IP68		

Ordering
Accessories

Replacement handles		
Type of handle	Fixation	Code No.
T Alu. DN 15-25	spring pin	065N8255
L Steel DN 15-32 with plastic grip	spring pin	065N8256
L Steel DN 40-50 with plastic grip	spring pin	065N8257
L Steel DN 65 with plastic grip	spring pin	065N8258
L Steel DN 80 with plastic grip	spring pin	065N8259
L Steel DN 100 with plastic grip	spring pin	065N8262
L Steel DN 125 with plastic grip	spring pin	065N8260
L Steel DN 150 with plastic grip	spring pin	065N8261
L Steel angled DN 200 with plastic grip	screw	065N8001

Handles with extended shaft for pipes with thick insulation						
Type of handle	Code No.	Valve DN	H	h	S	Picture
Handle DN15-32 RB L115-H	065N8350	15	142	196	115	
		20	142	196	115	
		25	142 (157) ¹⁾	199 (214) ¹⁾	115	
		32	141 (155) ¹⁾	204 (218) ¹⁾	115	
Handle DN 40-50 RB L157-H	065N8351	40	170 (201) ¹⁾	248 (279) ¹⁾	157	
		50	174 (200) ¹⁾	252 (284) ¹⁾	157	
Handle DN 65 RB L205-H	065N8352	65	188	283	205	
Handle DN 80-100 RB L405-H	065N8353	80	210	334	405	
		100	227	367	405	
Handle DN 125 RB L505-H	065N8354	125	225	412	505	
Handle DN 150 RB L645-H	065N8355	150	231	451	645	
Handle DN200RB L645-HexT-H	065N8356	200	245	492	645	

¹⁾ Valid for flanged version (FF)

Marking knobs for handles DN15-100 (red/blue)	Code No.
Red knobs (bag with 100 pieces)	065N8303
Blue knobs (bag with 100 pieces)	065N8304

Technical data

DN [mm]	15	20	25	32	40	50	65	80	100	125	150	200	250	300	350	400	450	500	600	
K _{V5} [m ³ /h]	8/11*	15	34	52	96	184	200	470	640	1,080	1,900	2,300	5,100	9,100	7,000	10,400	26,300	23,700	14,300	
PN	16/25/40						16/25													
Temp range	0-180 °C																			
Medium	Circulation water / glycolic water up to 50 %																			

*K_{V5} for the codes 065N1100, 065N1101 and 065N1102 is 8 [m³/h], K_{V5} for all other DN 15 codes is 11 [m³/h]

Design & Material

DN 15-50 with handle

1	Welding end	*Weldable mild steel 20#
1A	Flange	*Weldable mild steel 20#
2	Shell	*Weldable mild steel 20#
3	Ball seal retainer	*Weldable mild steel 20#
4	Ball	Stainless steel
5	Ball seal	Carbon reinforced PTFE
6	Stem	Stainless steel
7	Washer	Carbon reinforced PTFE
8	Stem sealing rings	Carbon reinforced PTFE
9	Compression nut	Steel
10	Packing box	*Weldable mild steel 20#
11	Pin	Spring steel
12	Handle	Steel

Design & Material

1	Welding end	*Weldable mild steel 20#
1A	Flange	*Weldable mild steel 20#
2	Shell	*Weldable mild steel 20#
3	Ball seal retainer	*Weldable mild steel 20#
4	Ball	Stainless steel
5	Pipe insert	Stainless steel
6	Support ring	Stainless steel
7	Disc spring	Domex 650 MC
8	Ball seal	Carbon reinforced PTFE
9	Stem	Stainless steel
10	Washer	Carbon reinforced PTFE
11	Stem sealing rings	Carbon reinforced PTFE
12	Compression ring	Steel
13	Compression nut	Steel
14	Packing box	*Weldable mild steel 20#
15	Pin	Spring steel
16	Handle	Steel

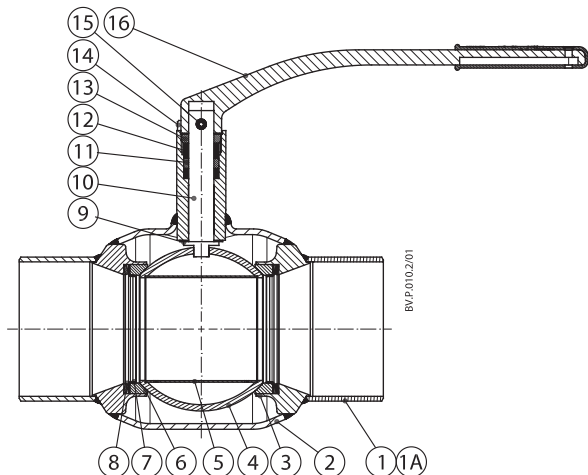
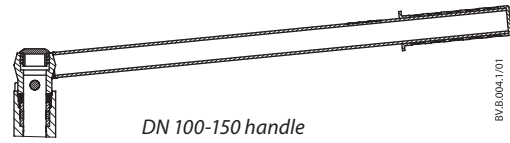

1	Welding end	*Weldable mild steel 20#
1A	Flange	*Weldable mild steel 20#
2	Guiding pipe	*Weldable mild steel 20#
3	Shell	*Weldable mild steel 20#
4	Ball seal retainer	*Weldable mild steel 20#
5	Ball	Stainless steel
6	Pipe insert	Stainless steel
7	Ball seal	Carbon reinforced PTFE
8	Disc spring	Domex 650 MC
9	Stem	Stainless steel
10	Washer	Carbon reinforced PTFE
11	Packing box	*Weldable mild steel 20#
12	Stem sealing rings	Carbon reinforced PTFE
13	Compression ring	Steel
14	Compression nut	Steel
15	Stopsector	Stainless steel
16	Handle	Steel

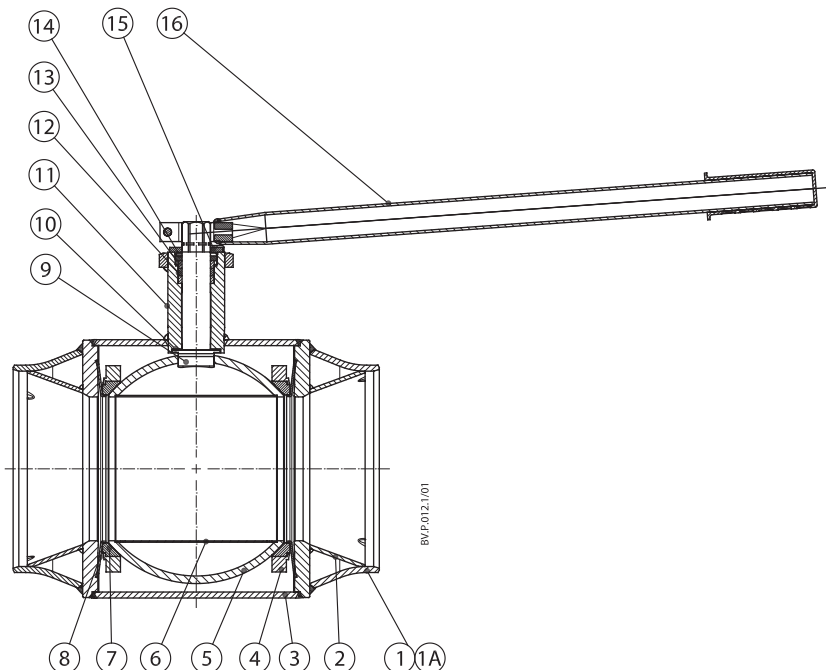

DN 200 with handle

Design & Material

1	Welding end	*Weldable mild steel 20#
1A	Flange	*Weldable mild steel 20#
2	Guiding pipe	*Weldable mild steel 20#
3	Shell	*Weldable mild steel 20#
4	Ball seal retainer	*Weldable mild steel 20#
5	Ball	Stainless steel
6	Guide pipe	Stainless steel
7	Ball seal	Carbon reinforced PTFE
8	Disc spring	Domex 650 MC
9	Stem	Stainless steel
10	Washer	Carbon reinforced PTFE
11	Packing box	*Weldable mild steel 20#
12	Stem sealing rings	Carbon reinforced PTFE
13	Compression ring	Steel
14	Compression nut	Steel
15	Simmerring	Rubber
16	Key	Steel

* According to the GB/T8163. Or equivalent mild steel in accordance with CE-PED

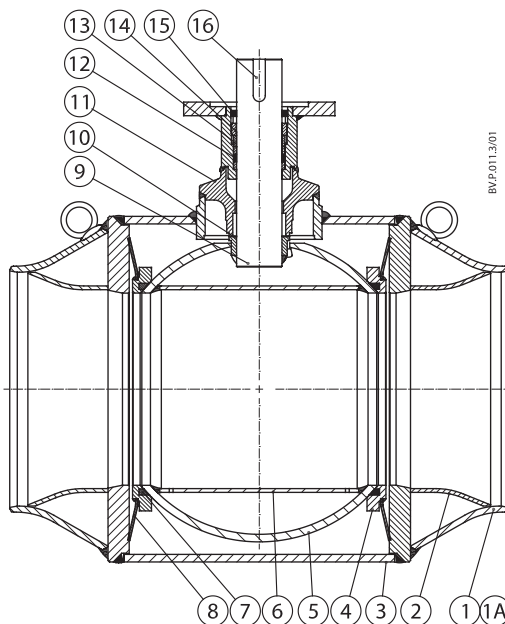

DN 65-600 with gear flange

BVP.011.3/01

Technical data

Pressure drop/velocity

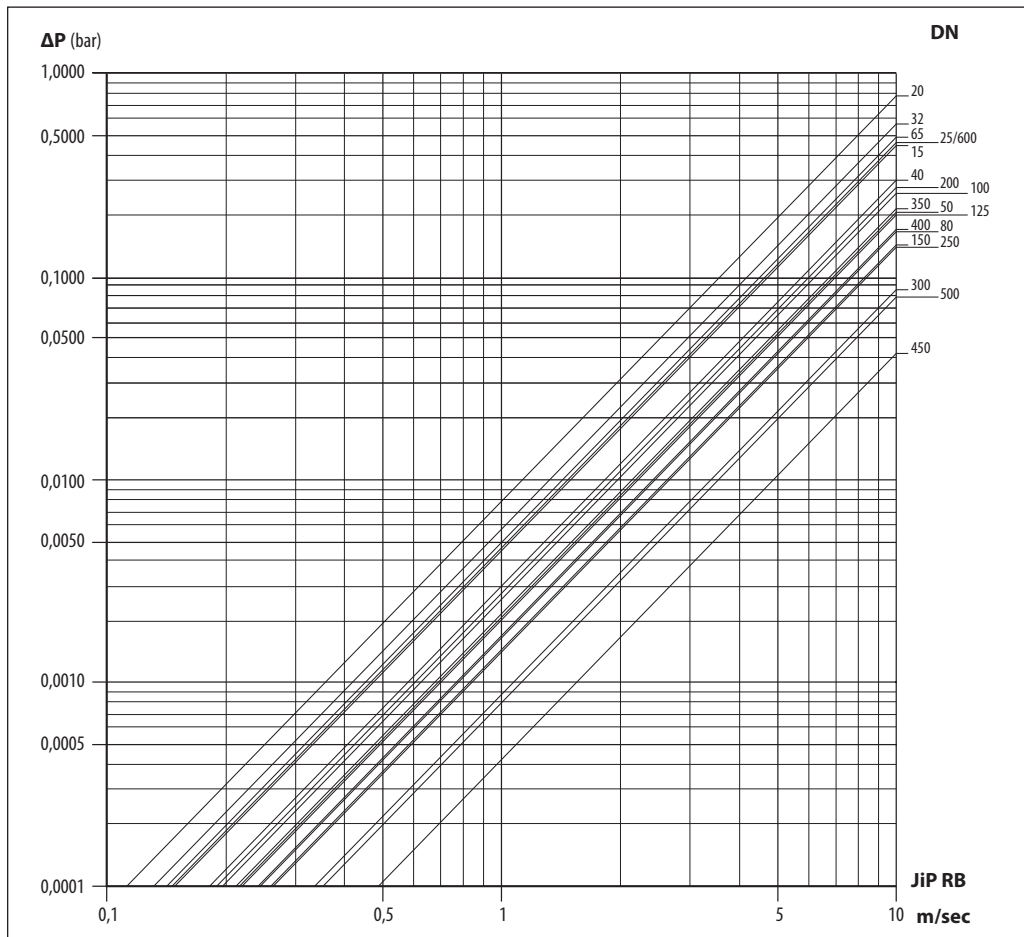

Technical data

Pressure drop/flow

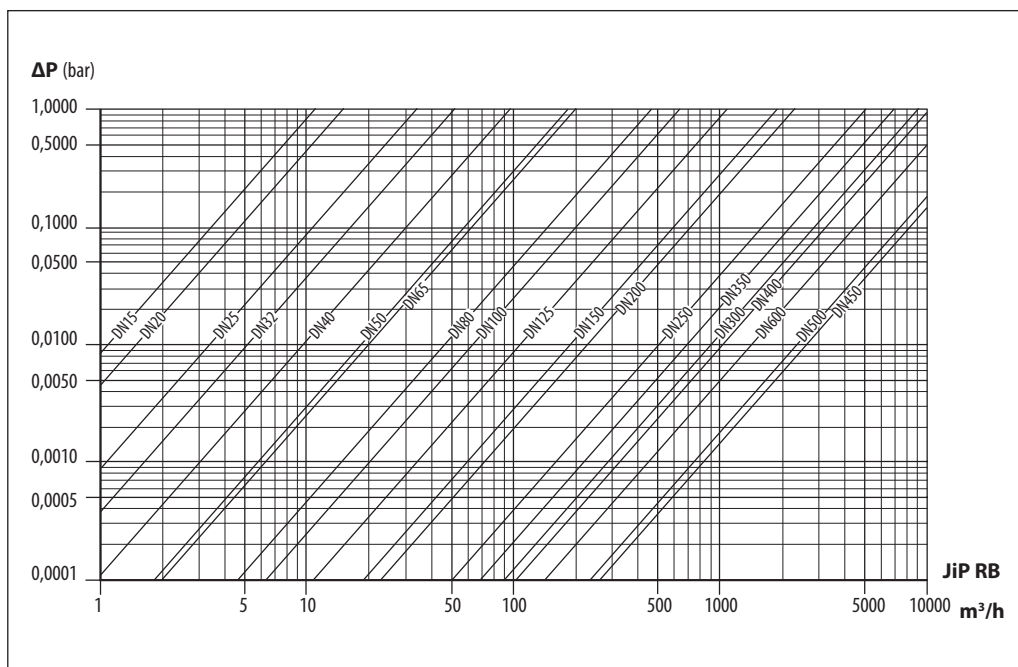

Pressure/temperature

JIP-WW

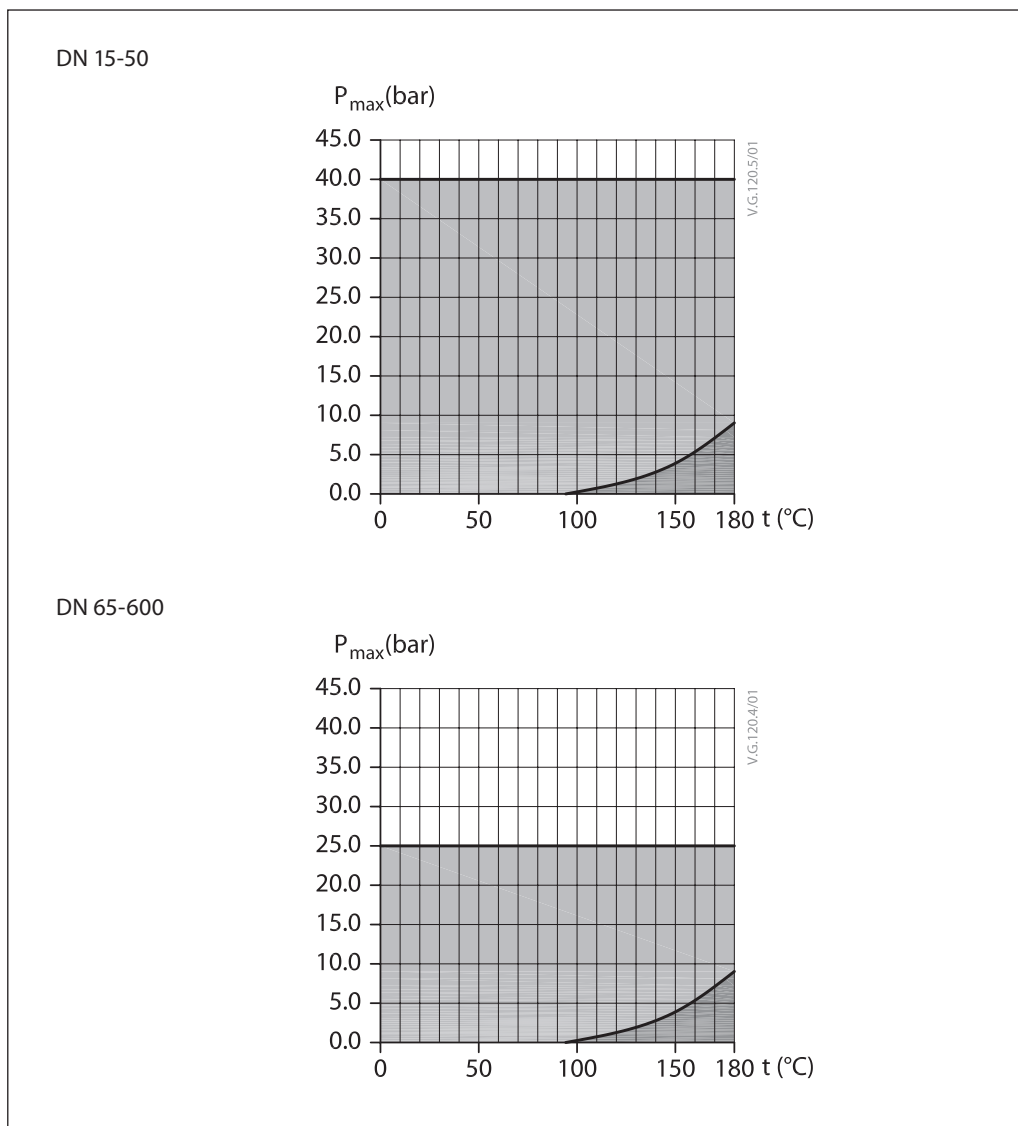

Legend:

- Normal operating area (water)
- Steam area

Pressure/temperature
JIP-FF

PN 16, DN 65-600

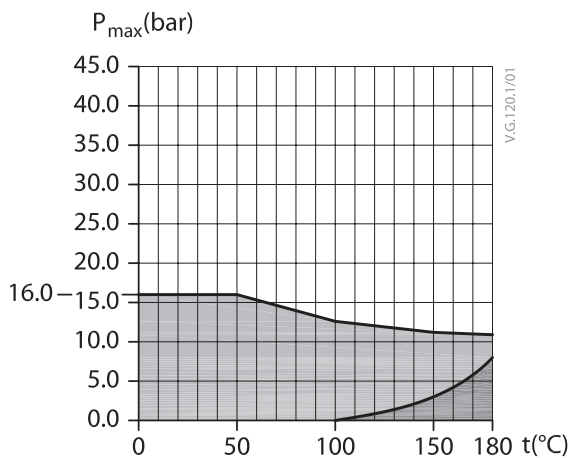

PN 25, DN 65-600

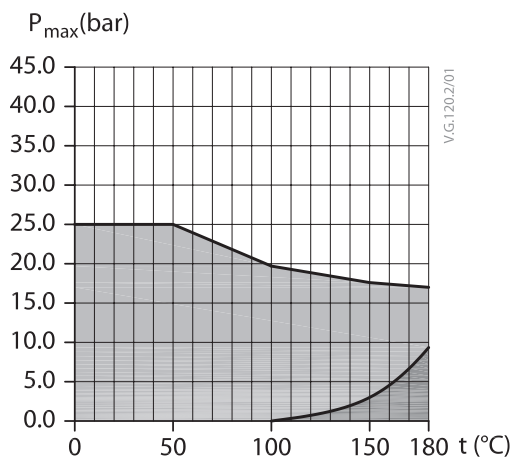

PN 40, DN 15-50

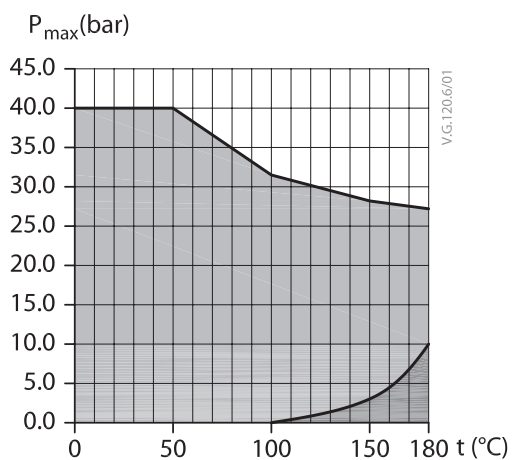

Legend:

- Normal operating area (water)
- Steam area

Dimensions
JIP-WW welding/
welding

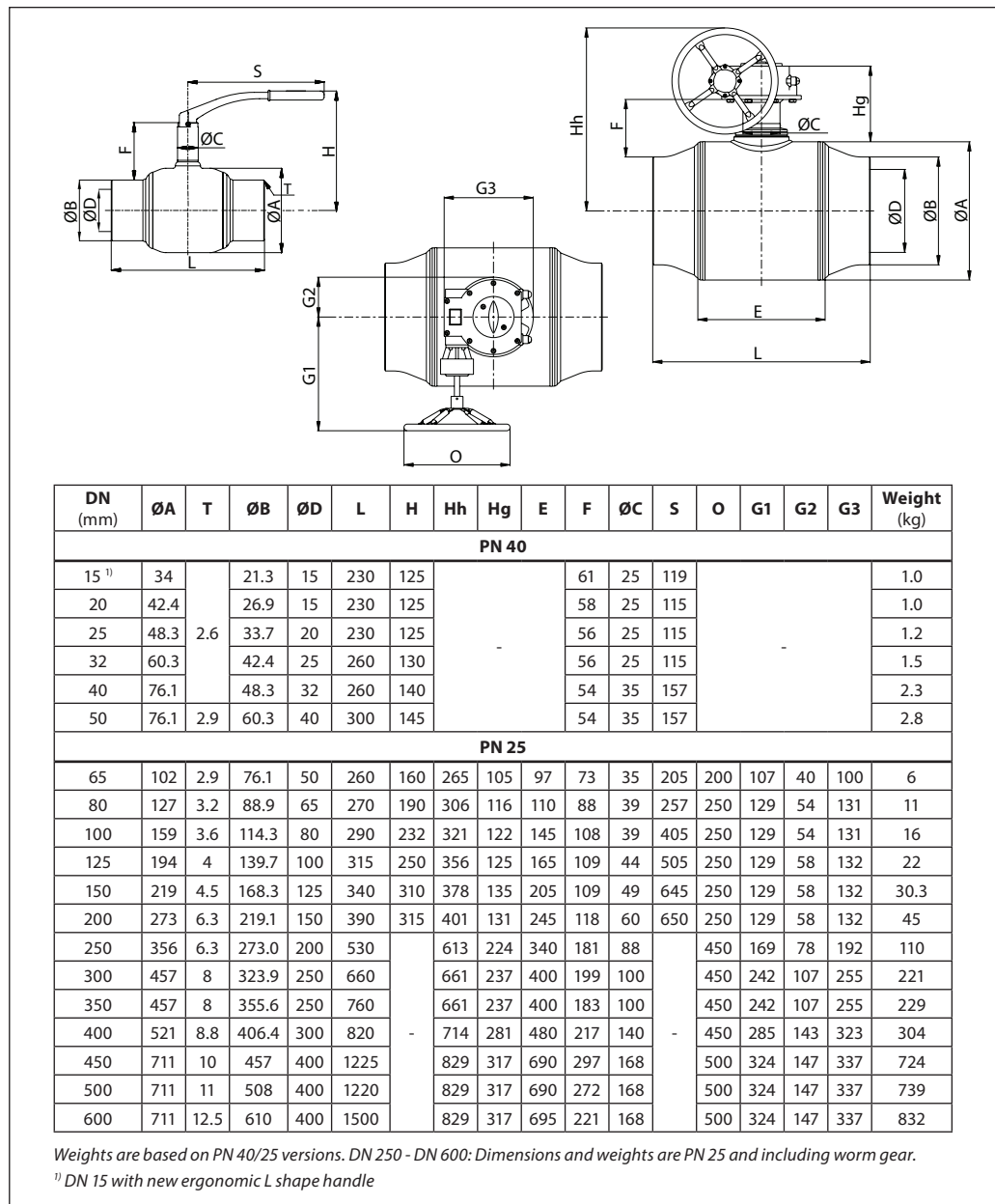

JIP-II internal thread

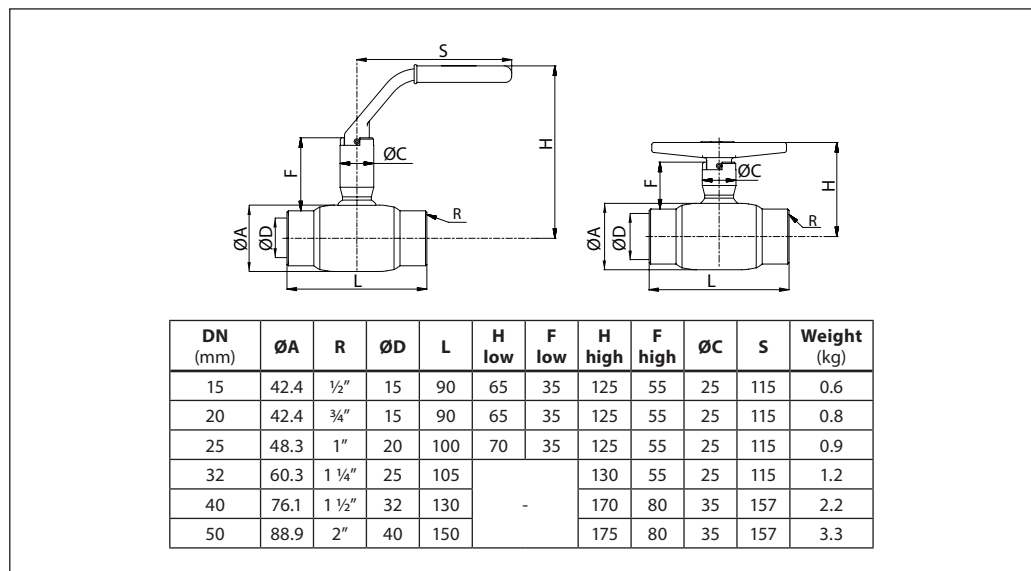

Dimensions

JIP-FF flange/flange

DN (mm)	ØA	ØD*	PN 16			PN 40			H	Hh	Hg	E	F	ØC	S	O	G1	G2	G3	Weight (kg)
			L	DF	I	L	DF	I												
15 ¹⁾	34	15	-	-	-	130	95	23	125	-	-	-	58	25	119	-	-	-	-	2.2
20	42.4	15	-	-	-	150	105	19	125	-	-	-	58	25	115	-	-	-	-	2.9
25	48.3	20	-	-	-	160	115	15	125	-	-	-	57	25	115	-	-	-	-	3.5
32	60.3	25	-	-	-	180	140	10	130	-	-	-	59	25	115	-	-	-	-	4.8
40	76.1	32	-	-	-	200	150	35	170	-	-	-	86	35	157	-	-	-	-	6.5
50	76.1	40	-	-	-	230	165	35	175	-	-	-	86	35	157	-	-	-	-	8.7
-	-	-	PN 16			PN 25			-											
65	102	50	270	185	18	290	185	18	160	265	130	100	73	35	205	200	107	40	100	12
80	127	65	280	200	33	310	200	33	190	306	117	110	88	39	260	250	129	54	131	18
100	159	80	300	220	56	350	235	48	225	321	125	135	108	39	260	250	129	54	131	26
125	194	100	325	250	54	400	270	44	215	356	144	165	109	44	355	250	129	58	132	32
150	219	125	350	285	51	480	300	43	235	378	155	205	109	49	505	250	129	58	132	45
200	273	150	400	340	66	600	360	56	315	401	149	245	126	60	650	250	129	58	132	74
250	356	200	650	405	115	730	425	105	-	613	228	340	181	88	-	450	169	78	192	165
300	457	250	750	460	131	850	485	119	-	661	254	400	199	100	-	450	242	107	255	262
350	457	250	850	520	101	980	555	84	-	661	254	400	183	100	-	450	242	107	255	289
400	521	300	1100	580	130	1100	620	110	-	714	285	480	220	140	-	450	285	143	323	400
450	711	400	1255	640	206	1255	670	191	-	829	322	690	297	168	-	500	324	147	337	819
500	711	400	1250	715	169	1250	730	161	-	829	322	690	272	168	-	500	324	147	337	866

Weights are based on PN 40/25 versions. DN 250 - DN 600: Dimensions and weights are PN 25 and including worm gear.
 ØD* - internal nominal diameter
¹⁾ DN 15 with new ergonomic L shape handle

JIP-IW internal head/welding

DN (mm)	ØA	ØB	R	ØD*	L	H		F	H		F	ØC	S	Weight (kg)
						low T	low		high L	high				
15	42.4	21.3	1/2"	15	160	65	40	125	60	25	115	0.9		
20	42.4	26.9	3/4"	15	160	65	37	125	60	25	115	0.9		
25	48.3	33.7	1"	20	165	70	37	125	55	25	115	1.0		
32	60.3	42.4	1 1/4"	25	185	-	-	130	58	25	115	1.4		
40	76.1	48.3	1 1/2"	32	195	-	-	170	86	35	157	2.3		
50	88.9	60.3	2"	40	225	-	-	175	86	35	157	3.3		

ØD* - internal nominal diameter

Dimensions

JIP-FW flange/welding

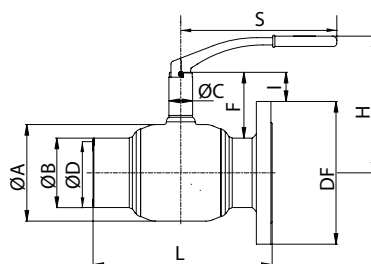

DN (mm)	ØA	ØB	ØD*	PN 16			PN 40			H	F	C	S	Weight (kg)
				L	DF	I	L	DF	I					
15 ¹⁾	34	21.3	15				180	95	23	125	58	25	119	1.7
20	42.4	26.9	15				190	105	19	125	58	25	115	2.0
25	48.3	33.7	20				195	115	15	125	57	25	115	2.4
32	60.3	42.4	25				220	140	10	130	59	25	115	3.4
40	76.1	48.3	32				230	150	35	170	86	35	157	4.3
50	88.9	60.3	40				265	165	35	180	86	35	157	5.9
				PN 16			PN 25							
65	102	76.1	50	265	185	18	265	185	18	160	73	35	205	7
80	127	88.9	65	275	200	33	275	200	33	190	88	39	260	9
100	159	114.3	80	295	220	56	295	235	48	225	108	39	260	15
125	194	139.7	100	320	250	54	320	270	44	250	109	44	355	23
150	219	168.3	125	345	285	51	345	300	43	285	109	49	505	35
200	273	219.1	150	395	340	66	395	360	56	315	126	60	650	65

Weights are based on PN 40/25 versions. DN 250 - DN 600: Dimensions and weights are PN 25 and including worm gear.

ØD* - internal nominal diameter

¹⁾ DN 15 with new ergonomic L shape handle

Valve top and gear flange

DN (mm)	Gear flange	mm					
		l	Ød	n	p	q	r
65	F07	31	16	27	5	13	4
80		45	20	41	6	165	
100		43		39			
125	F10/F12	50	30	46	8	26	6
150							
200	F16	60	50	48	14	44.5	5
250		65	60	51	18	53.2	6
300							
350	F25	75	75	60	20	60	6
400							
450	F25	115	100	91	28	80	6
500							
600							

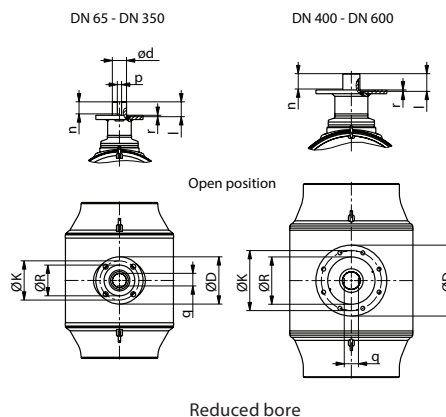

Gear flange	No. of bolt holes	Diameter of bolt holes	mm		
			ØD	ØK	ØR
F7	4	9	88	70	55
F10		11	125	102	70
F12		13	150	125	85
F16		21	210	165	130
F25	8	17	300	254	200
F30		21	350	298	230

Dimensions

House insertions
 Single valve
 JIP-CC copper
 JIP-IC internal thread / copper
 Max temp. 130°

DN (mm)	ØA	ØB	L CC	L IC	H	Weight (kg)
PN 16						
15	42.4	18/21.3/18	245	168	125	0.93
20	42.4	22	255	175	125/125/105	0.93
25	48.3	28	255	180	125	1.10

ØD* - internal nominal diameter

House insertions
 Twin valve - single pipe
 JIP-IC internal thread/copper
 Max temp. 130°

DN (mm)	A	C	H	Weight (kg)
PN 16				
15	100-145	115-200	65	2.83
20	100-145	115-200	65	2.75

House insertions
 Twin valves - single pipe
 JIP-WW welding
 JIP-II internal thread
 JIP IW internal thread/welding

DN (mm)	A	C	H	Weight (kg)
PN 40				
15	100-145	115-200	65	2.2
20	100-145	115-200	65	2.2
25	100-145	115-200	70	2.3
32	115-160	115-200	115	3.5

Dimensions

House insertions

Twin valves - double pipe

JIP-II/JIP-IW internal thread

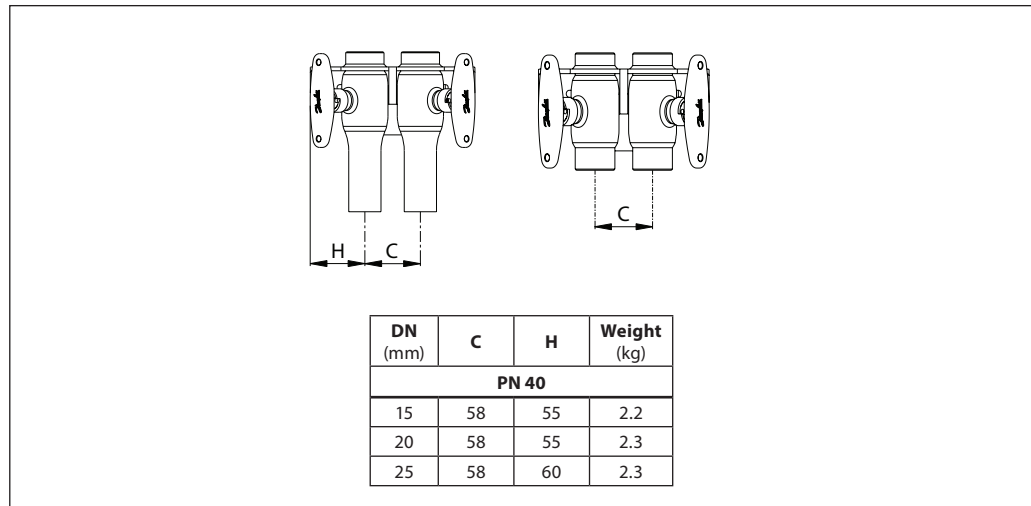

JIP-WE cc welding / external thread with closing cap

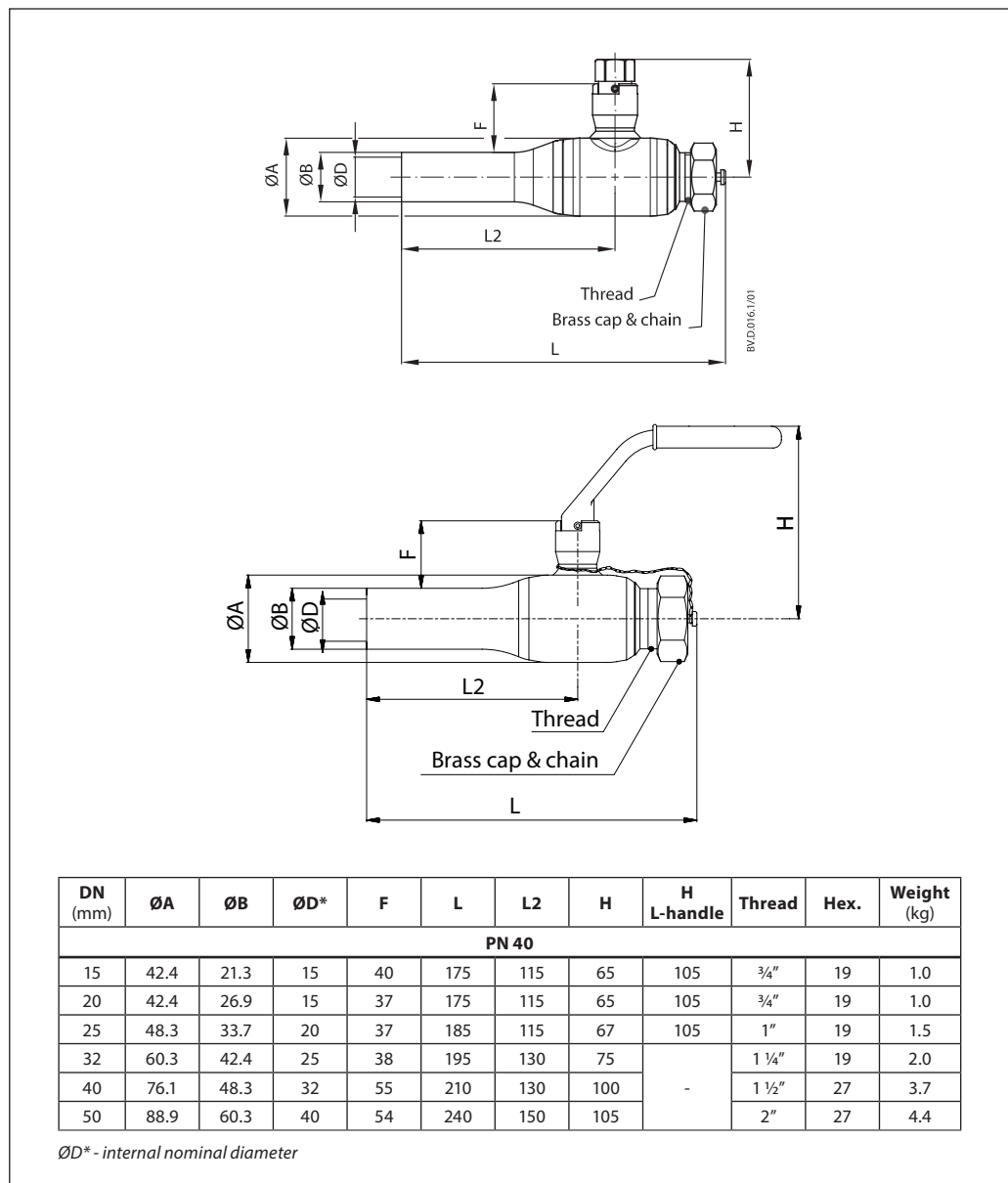

AUMA NORM electrical actuators for Danfoss ball valves

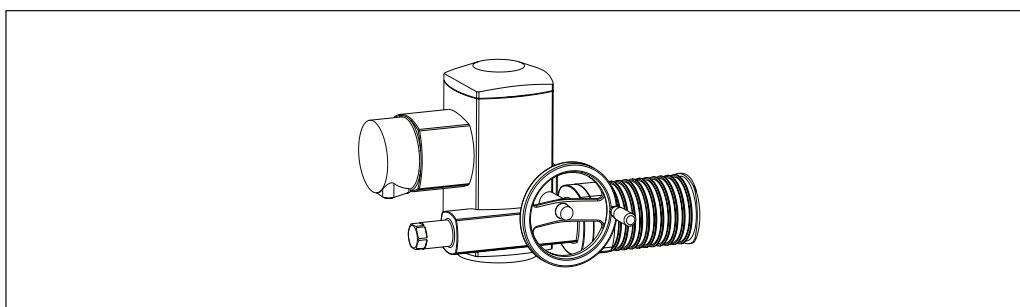

Danfoss ball valves	Auma Actuators	
DN (mm)	Type	Operating time for 90° turn (s)
65-80	SQ 05.2	16
100	SQ 07.2	32
125-150-200	SQ 10.2	32
250	SA 07.6+GS 100.3+VZ 4.3	142
300-350	SA 07.6+GS 125.3+VZ 4.3	142
400	SA 10.2+GS 125.3+VZ 4.3	142
450-500-600	SA 10.2+GS 160.3+GZ 160.3	207

The actuators can be equipped with various accessories. Control and regulating unit AUMA Matic in the basis design can be supplied. For other mains voltages than 3 × 400V/50Hz or additional questions please contact us.

When commissioning and under certain problematic system conditions, it can be necessary to choose slower actuators to avoid water hammering and oscillations.

Features:

- 2 limit switches - opening/closing
- 2 torque switches - opening/closing
- Heater
- Blinker switch for operating phase
- Manual operation with hand wheel
- Thermo switch

Main Data:

- Nominal voltage: 3 × 400 VAC, 50Hz
- Grade of enclosure: IP 68
- Wiring diagram: TPA 00R1AA-000

