

Technical brochure

Pressure controls, Type BCP



The BCP type is a series of dedicated pressure controls for safety and pressure monitoring of steam and hot water boilers.

The BCP incorporates a single-pole changeover microswitch where the contact position depends on the pressure in the connection port and the range set value.

For installations, in which operation is particularly critical for safety reason, the use of fail-safe control is recommended.

Features

- Available as high and low pressure limiters as well as pressure controllers
- Wide pressure range: from low pressure BCP1 with narrow differential to high pressure BCP7
- The fail-safe dual bellows enable premature cut-out when fault occurs
- DIN plug mounted on the top of control for easy electrical wiring
- Single-pole changeover switch (SPDT), switch + alarm
- Direct mounting on pressure connection or wall mounting by means of a bracket
- Versions with automatic and manual resets available
- Screw adjustments made on top of housing
- Manual reset for pressure limiters possible only by means of tools
- Version with gold plated contact for electronic devices
- Safety Integrity Level: SIL 2 according to IEC 61508:2010

Approvals

CE-marked in accordance with EN 60947-4/-5
VdTÜV-Merkblatt „Druck 100“
TÜV. SDWFS/SDBFS . 08 - 335

CE marked in accordance with PED 97/23/ED,
category IV, safety equipment, testing basis
pr EN12952-11 and EN12953-9.

Materials in contact with media

Bellows: stainless steel 1.436 (18/8)
Pressure connection: nickel plated free cutting steel

Technical data

Media

Steam, water, air

Ambient temperature

-20 to 70°C

Media temperature

Up to 120°C

(Above 120°C a water-filled loop must be installed)

Enclosure

IP 65

Action type acc. to EN 60730

Type BCP - 2B

Types BCPL/ BCPH - 2BDF

Electrical connection

Plug, DIN 43650, Pg 11

Switch type

SPDT, snap action microswitches:
type A and type B

Contact material:

Type A: Silver/ gold (Au plated Ag)

Type B: Silver (AgCdO)

Contact load

BCP type A (silver/ gold contact)

Minimum:

4mA, 5V

Maximum: ¹⁾

²⁾ AC-1: 6A, 250V

³⁾ AC-15: 1A, 250 V

⁴⁾ DC 13 10W, 250 V

Contact load

BCP type B (silver contact)

Minimum:

500mA, 24V

Maximum: ¹⁾

²⁾ AC-1: 10A, 250V

³⁾ AC-15: 2A, 250V

⁴⁾ DC 13: 50W, 250V

Expected electrical lifetime

Min. 250 000 cycles under full contact load

¹⁾ If used with current higher than 400mA the gold will disappear and the unit can't be used at a lower current again.

²⁾ AC-1 Ohmic load, cosφ 1

³⁾ AC-15 inductive load like coil and contactors with, cosφ 0.3

⁴⁾ DC-13 Direct current load

Ordering
High pressure limiters

Type	Range [bar]	Fixed Differential avg. [bar]	Reset	Max. operating pressure [bar]	Max. test pressure [bar]	Pressure connection	Code no. Contact type A	Code no. Contact type B
BCP1H	0.1 to 1.1	0.1	Man.	6	7	G $\frac{1}{2}$ A	017B0030	017B0029
BCP2H	0 to 2.5	0.2		10	11		017B0034	017B0033
BCP3H	0 to 6	0.4		16	18		017B0038	017B0037
BCP4H	1 to 10	0.45		25	28		017B0042	017B0041
BCP5H	2 to 16	1.2		32	35		017B0046	017B0045
BCP6H	5 to 25	1.5		40	45		017B0050	017B0049
BCP7H	10 to 40	2.3		63	70		017B0054	017B0053

Low pressure limiters

Type	Range [bar]	Fixed Differential avg. [bar]	Reset	Max. operating pressure [bar]	Max. test pressure [bar]	Pressure connection	Code no. Contact type A	Code no. Contact type B
BCP2L	0 to 2.5	0.2	Man.	10	11	G $\frac{1}{2}$ A	017B0058	017B0057
BCP3L	0 to 6	0.4		16	18		017B0062	017B0061
BCP4L	1 to 10	0.45		25	28		017B0066	017B0065
BCP5L	2 to 16	1.2		32	35		017B0070	017B0069
BCP6L	5 to 25	1.2		40	45		017B0074	017B0073

Pressure controllers

Type	Range [bar]	Adjust. Differential [bar]	Reset	Max. operating pressure [bar]	Max. test pressure [bar]	Pressure connection	Code no. Contact type A	Code no. Contact type B
BCP1	0.1 to 1.1	0.15 to 0.6	Auto	6	7	G $\frac{1}{2}$ A	017B0002	017B0001
BCP2	0 to 2.5	0.4 to 1.0		10	11		017B0006	017B0005
BCP3	0 to 6	0.7 to 1.4		16	18		017B0010	017B0009
BCP4	1 to 10	1.0 to 2.5		25	28		017B0014	017B0013
BCP5	2 to 16	2.0 to 3.2		32	35		017B0018	017B0017
BCP6	5 to 25	2.5 to 4.0		40	45		017B0022	017B0021
BCP7	10 to 40	3.0 to 6.0		63	70		017B0026	017B0025

Design and function

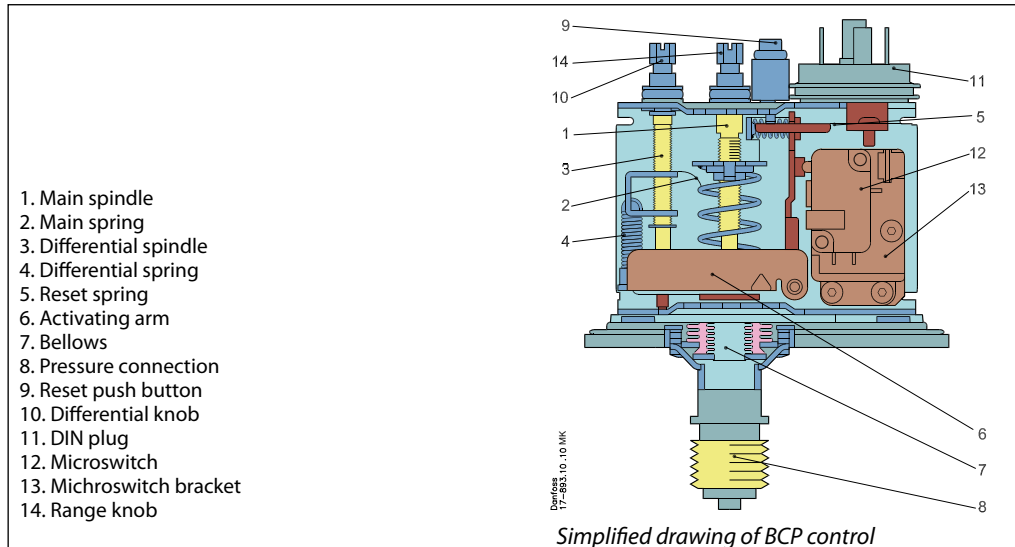

Reset

Version with automatic reset cut-in again automatically when the pressure falls to the set point minus differential. Version with manual reset has to be cut in manually by means of tool.

Fail-safe bellows concept

BCP6, BCP6H, BCP7, and BCP7H have a double bellows: an operating bellows (inner) and safety bellows (outer).

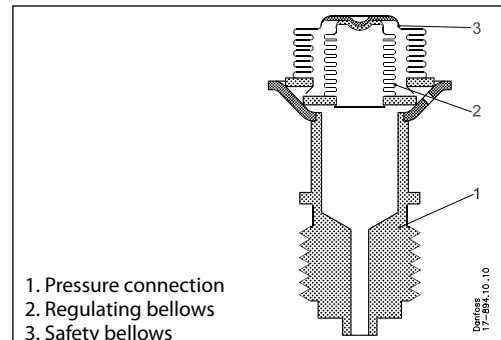
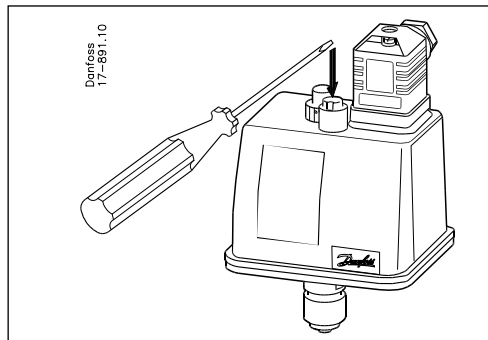

Microswitch

BCP is a microswitch based control with DIN plug. Such design enables easy electrical connection and makes control suitable for operation with modern electronic systems, as PLC.

Silver/gold plated and silver contacts

Silver/gold plated contacts (type A) are used for low currents and middle range of current, especially in applications with PLC or other corresponding electronic devices. Such contacts have also significantly lower emission of electromagnetic noises produced on contact break. EMC (Electro Magnetic Compatibility) is an important parameter where electronic equipment is used. A gold plated contact has a silver layer under the gold and can therefore also be used in the middle range of load. The gold will disappear at loads above 0.4 A. For loads higher than 0.5 A, contact type B is recommended. This contact is mainly used in application where the switch operate devices as coils, contactors and others which is in the high current area.

Note:

Ambient temperature influence

All BCP pressure controls operate independently of changes in ambient temperature around the control.

Therefore the settings for cut-out pressure and differential stay constant unless the permissible ambient temperature is exceeded.

When system pressure exceeds the set value, the BCP will automatically stop the plant.

A rupture in the inner bellows cause the control cut-out pressure to fall about 3 times less than the preset value, thus the system stops prematurely.

A rupture in the outer bellows cause the control cut-out pressure to fall about 3 bar under the preset value, thus providing a fail-safe function.

In other BCP types with single bellows assembly, fail-safe function is satisfied by proofed 2 millions cycles mechanical life time test.

Setting

Note:

Cut-in and cut-out pressures of the system should always be checked with accurate pressure gauges.

Pressure settings for controls (with automatic reset)

Set the cut-out pressure on RANGE scale and differential on DIFF. scale. Restart pressure is equal to cut-out pressure minus pre-set differential value.

Pressure controls with manual reset

High pressure limiters

Set cut-out pressure on the RANGE scale. Pressure limiter can only be manually reset by pressing reset button by means of tools when the pressure is equal to or below the cut-out pressure minus value of the differential.

Low pressure limiters

Set cut-out pressure on RANGE scale. Limiter can only be reset manually by pressing (with tool) the reset button when pressure rises to cut-out pressure plus differential or above it.

Note:

Pressure limiters have no differential scale. Fixed differential value is printed on the scale plate.

Terminology

Pressure limiters

Limiters are devices that, on reaching a fixed value interrupt and lock out the energy supply. Manual unlocking is required before restart. A limiter shall be such that a single fault in any related part shall not lead to a loss of the safety function.

Note:

If a BCP pressure controller with automatic reset is used as limiter, lockout must be realized externally as a part of safety logic, e.g.: by external contactors and/ or relays according to requirements of standard prEN501156-1 for safety relevant hardware. External closure must be interlocked, while loss of auxiliary energy must lead to closure.

Resetting must not be automated; it has to be performed manually.

Resetting on fault must lead to a repeated closure.

When BCP limits, is for rising or falling applications, the external safety logic must change to fail-safe position.

Fail-safe control

A control is fail-safe if it has the capability to remain in a safe condition or transition to a safe condition when a fault occurs.

Note:

If the system pressure exceeds MWP then accuracy of the control settings can be lost.

Maximum test pressure

The maximum pressure applied in strength or leakage tests on heating systems or components thereof.

Maximum working pressure

The maximum permissible pressure for safe functioning of the system or any of its components.

Snap function

A specific contact force is maintained in micro-switch until snap is initiated, therefore, contact bounce cannot occur as a result, for example, of slight vibrations before cut-out.

These design features ensure that the cut-out point of the BCP control remains very accurate and completely independent of the magnitude of the current load.

Set point

A predetermined value to which a control is adjusted and at which it performs its intended function.

Differential

The difference between pressure cut-out and pressure cut-in.

Reset

1. Manual reset

A unit with manual reset can only be restored to operational mode by activation of the external reset button.

2. Automatic reset

A unit with automatic reset is restored to operational mode automatically

Installation in steam systems

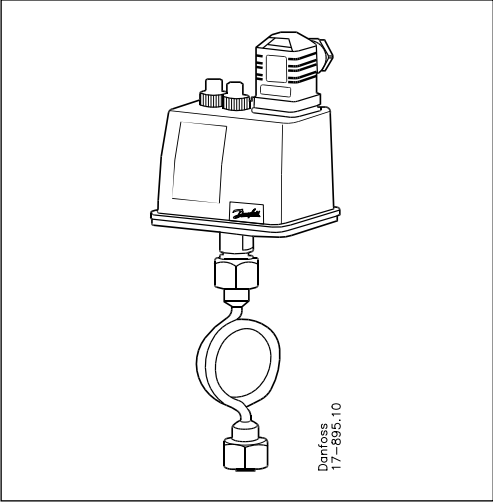

To protect the pressure element against excessive temperature of the media, above allowable 120°C the insertion of water-filled loop is recommended.

Dimensions and weights

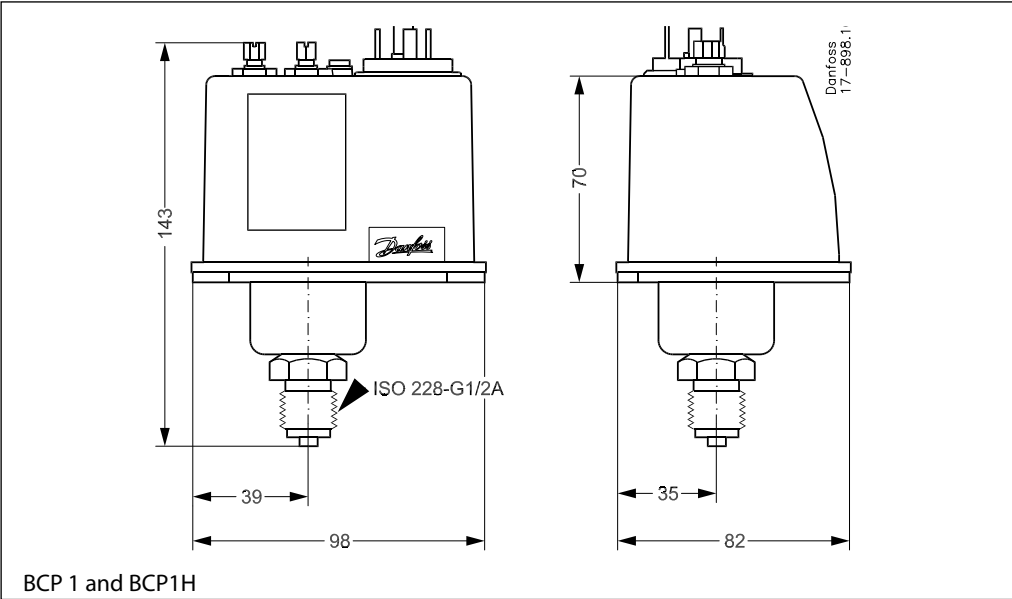
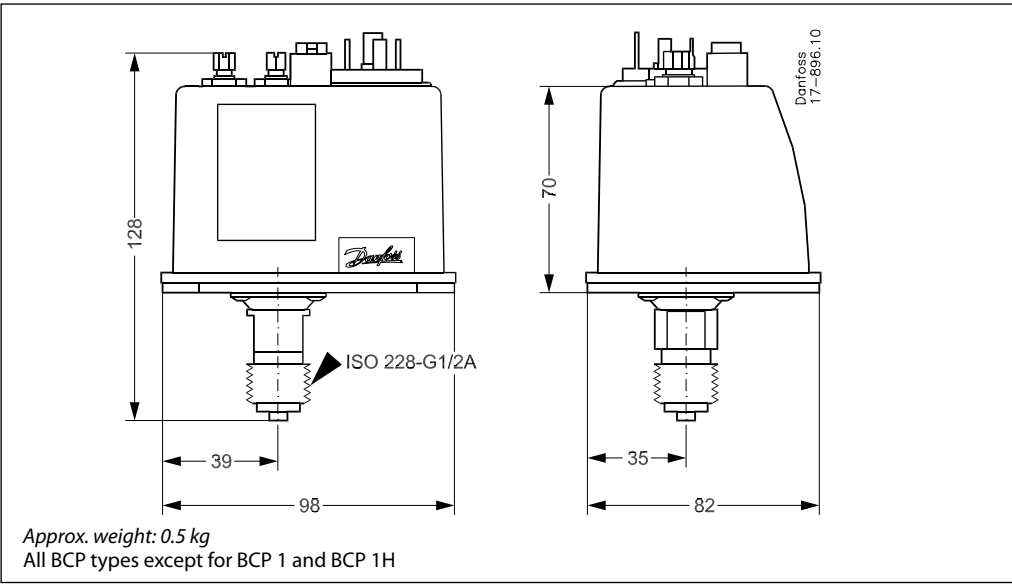

Accessories for BCP pressure controls

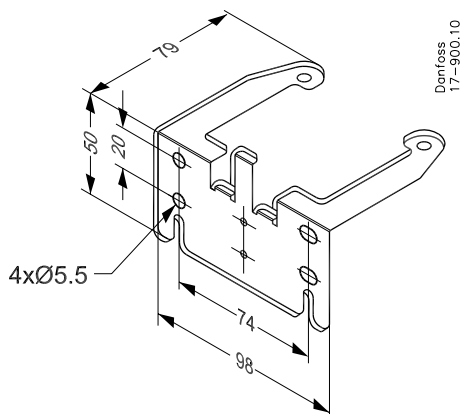

1. Mounting bracket, code number 017B1018, for direct mounting on the wall

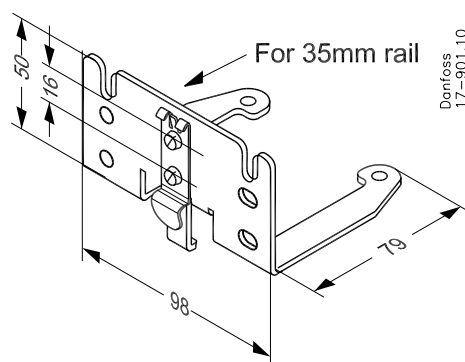

2. Mounting bracket for T 35 mm rail, code number 017B1019

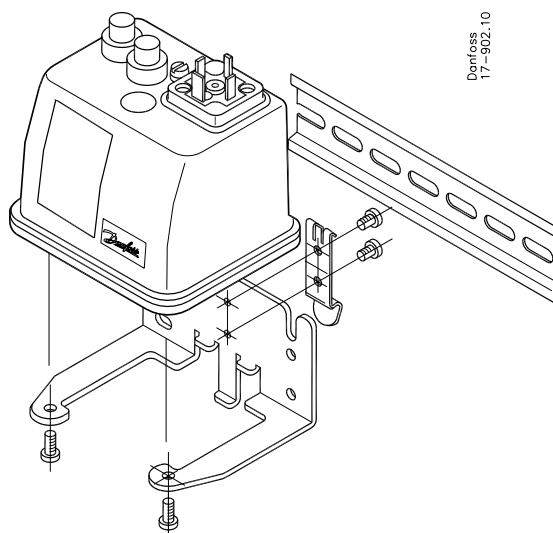

Illustration of mounting BCP on the 35 mm rail