

Oil Pump Type RSA Sizes 28, 40, 60, 95, 125



General Data Sheet

For specific information on this product, please contact Danfoss Burner Components

Identification

RSA 60 (Example)

- 28 Capacity 46 l/h
- 40 Capacity 75 l/h
- 60 Capacity 120 l/h
- 95 Capacity 184 l/h
- 125 Capacity 255 l/h

Capacity at 4.3 cSt., 10 bar, 2800⁻¹.

Note!

Shaft rotation, location of pressure outlet and other connections are seen from shaft end.

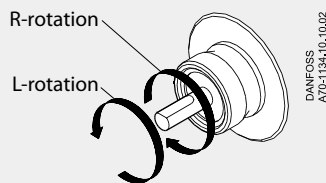

DANFOSS
A70-1154,10,10,02

Connections

Example shows L-rotation pump.
On R-rotating pumps location of connections are identical.

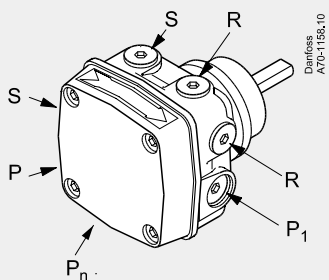

DANFOSS
A70-1154,10

- P₁ Pressure adjustment
- S Suction inlet G 1/4
- R Return outlet G 1/4
- P Pressure outlet G 1/8 (G 1/4 for RSA 125)
- P_n Pressure gauge port G 1/8
- H Filter

RSA oil pumps are designed for small/medium sized domestic and commercial oil burners up to 255 l/h. The pumps have a built-in pressure regulator with shut-off function. A special regulation spring is available for feed/transfer applications.

Application and Features

- Light oil and Kerosene
- 1 or 2-pipe operation
- 1-stage
- Built-in pressure regulator with shut-off
- Ring filter
- Spec. spring available for feed/transfer applications

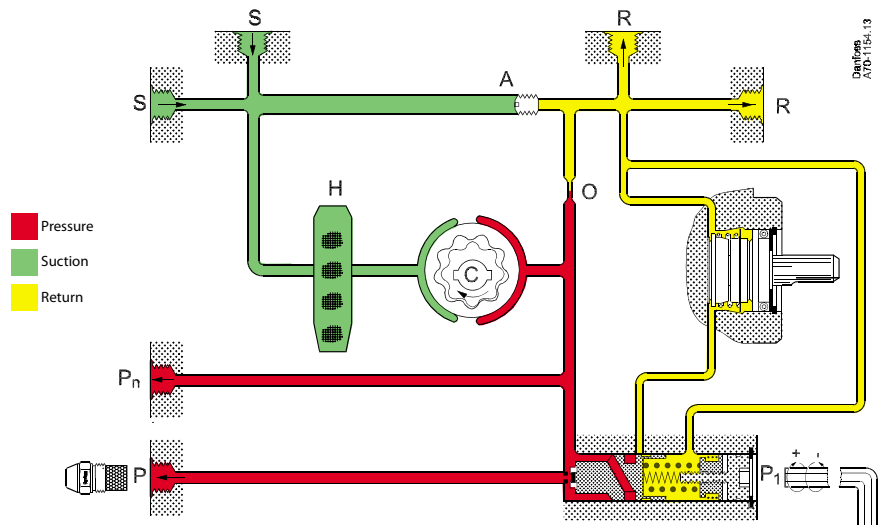

DANFOSS
A70-1154,13

Function

From the suction inlet (S) oil is drawn through the gear set, where the pressure is increased. By means of the piston and the spring in the pressure regulator the pressure is kept constant at the value set on adjustment screw (P₁).

In 2-pipe systems the excess oil is led back to the return outlet (R). In 1-pipe systems with plugged return outlet (R) and removed by-pass screw (A), the oil is returned internally to the gear set (see details in below figure). When the pump is stopped the pressure drops and the spring force in the pressure regulator will move the piston until it seats and the oil flow is shut off effectively.

Changeover between 1 and 2-pipe operation. Filter change

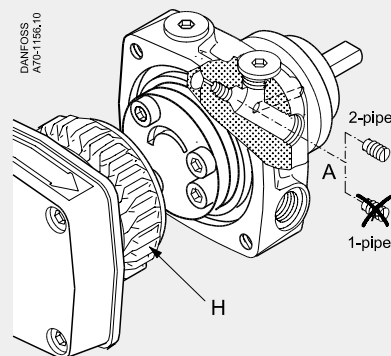

2-pipe: Screw (A) fitted
1-pipe: Screw (A) removed

Bleeding

In 2-pipe systems the pumps are self-priming, i.e. bleeding is performed via the constriction (O) to the return outlet (R).

In 1-pipe systems with plugged return outlet (R) and by-pass screw (A) removed, bleeding must be performed through the pressure gauge port (P_n).

In 1-pipe systems with underlying tank, the closing function of the regulating valve must be rendered inoperative. This is made by connecting the nozzle line to the pressure gauge port (P_n) and plug the pressure port (P). In this application a cut-off valve must be installed in the nozzle line.

Warranty

For pumps used outside the stated technical data and used with oil containing abrasive particles Danfoss cannot give any warranty.

Technical Data

RSH	Size	28	40	60	95	125
Viscosity range (measured in suction inlet)	cSt. (mm ² /s)	1.3 - 75				
Filter area/mesh	cm ² /μm	75/150			170/150	
Pressure range ¹⁾	bar	5.5-15	5.5-21			
Factory setting	bar	7 ±1			10 ±1	
Max. Pressure in suction inlet/return outlet	bar	4				
Speed	min ⁻¹	2400-3450		1400-3450		
Max. starting torque	Nm	0.20	0.22	0.24	0.30	0.35
Ambient temperature	°C	-20 to +120				
Storage temperature	°C	-25 to +120				
Temperature of medium	°C	-10 to +120				
Neck/Flange		EN 225				

¹⁾ Max. 12 bar at 1.3-1.8 cSt.

Nozzle capacity

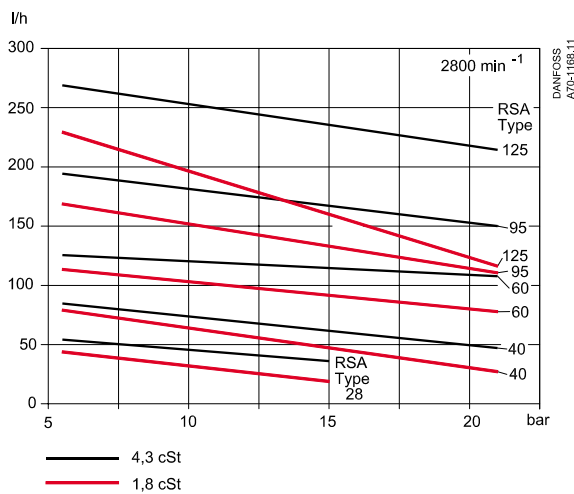

Operating torque

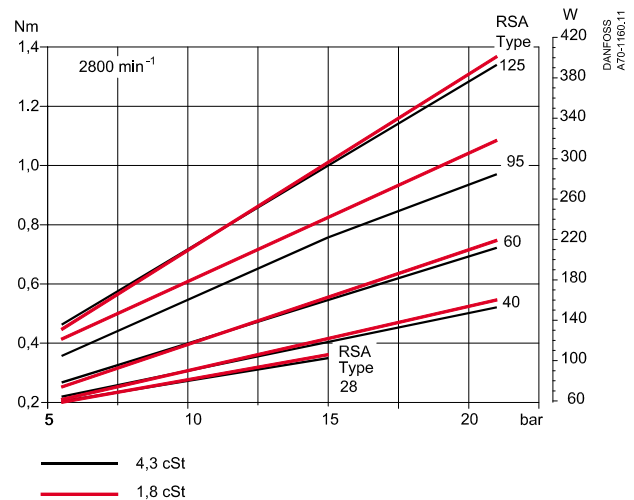

Dimensions

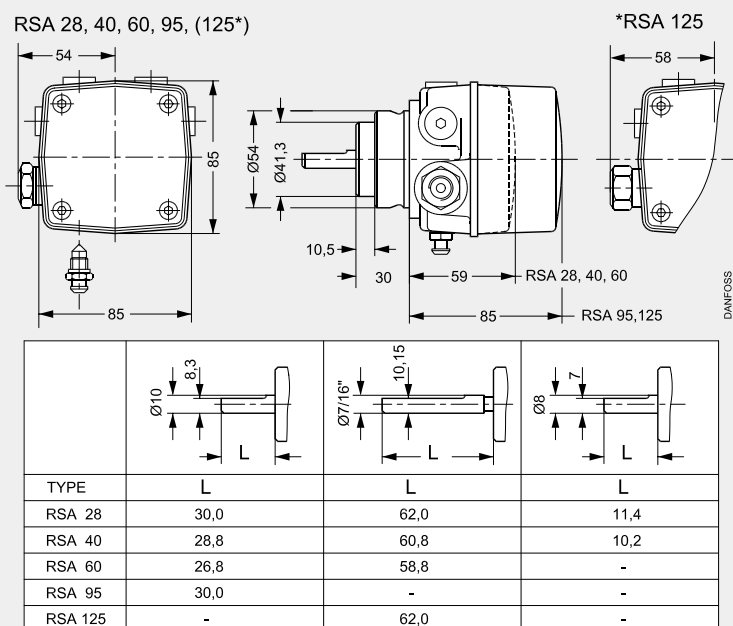

Danfoss can accept no responsibility for possible errors in catalogues, brochures and other printed material. Danfoss reserves the right to alter its products without notice. This also applies to products already on order provided that such alterations can be made without consequential changes being necessary in specifications already agreed. All trademarks in this material are property of the respective companies. Danfoss and the Danfoss logotype are trademarks of Danfoss A/S. All rights reserved.