



Pumpautomat Asso Jet gjutjärn

Benämning

Pumpautomat med tillhörande hydropress tank och automatik.

Användningsområde

Bevattning, Eget vatten.

Konstruktion

Pumpautomat av självsugande Jetpump med tillhörande hydropress tank och automatik. Pumpen är utrustad med enfas- eller trefasmotor. Enfasmotorn är försedd med termiskt motorskydd. Trefasmotorn ska kopplas över lämpligt motorskydd.

Tryck och temperatur

Max arbetstryck: 8 bar
Arbetstemperatur: 0°C/+35°C, omgivning +40°C.

Godkännande

CE.

Materialspecifikation

Pumphus	Gjutjärn
Hydropress	Lackerad stålplåt
Slang	EPDM med galvomflätning
Tryckströmbrytare	Plast/Aluminium
Tryckmätare	Plast/Mässing



Pumpautomat Asso Jet gjutjärn

Artnr	RSK	Typ	Effekt(P2) kW	Ström A	Ansl inv G	Lyfthöjd max m	Flöde max l/min	Tank volym l	Tank färg
0638242000	5950272	Asso Jet 82 M-60	0,60	3,8	1 x 1	47	60	60	Vit
0638246000	5950288	Asso Jet 102 T-60	0,75	1,9	1 x 1	53	60	60	Vit
0631052000	5950274	Asso Jet 151 T-100	1,00	3,1	1 1/4 x 1	62	80	100	Röd
0631055000	5950245	Asso Jet 251 T-100	1,85	4,0	1 1/4 x 1	63	120	100	Röd

Dessa pumpautomater levereras omonterade.

M = 1 x 230 V

T = 3 x 400 V

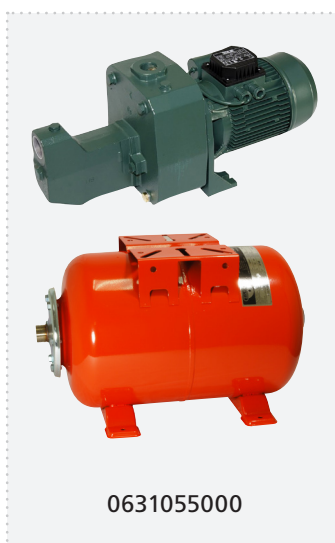

PUMPAUTOMAT

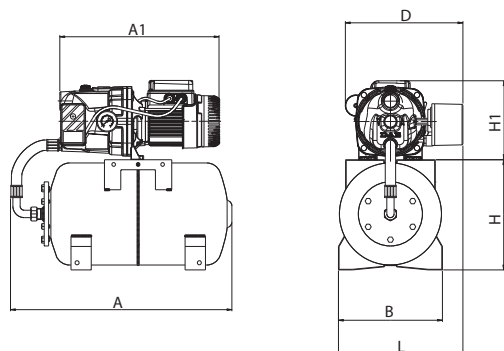

MODEL	A	A1	B	D	H	H1	L	PACKING DIMENSIONS			VOLUME m ³	WEIGHT Kg
								L/A	L/B	H		
AQUA 82 M-20	543	390	255	288	270	239	305	566	360	510	0,104	18,2
AQUA 102 M-20	543	409	255	293	270	239	305	566	360	510	0,104	20,0
AQUA 112 M-20	543	409	255	293	270	239	305	566	360	510	0,104	21,0
ASSO 82 M-60	750	390	380	288	410	239	380					24,2
AQUA 102 M/T-60	750	409	380	293	410	239	380					26,0

MODEL	A	B	H	H1	DNM	PACKING DIMENSIONS			VOLUME m ³	WEIGHT Kg
						L/A	L/B	H		
JET 151 -45/50	870	450	480	255						50
JET 251 -45/100	870	450	480	255						50

MODEL	ELECTRICAL DATA							HYDRAULIC DATA (n _~ 2850 1/min)													
	VOLTAGE 50 Hz	P1 MAX kW	P2 NOMINAL		I _n A	CAPACITOR		Q													
			kW	HP		μF	Vc	m ³ /h	0	0,6	1,2	1,8	2,4	3	3,6	4,2	4,8				
AQUAJET 82 M	1x220-240 V	0,85	0,6	0,8	3,8	12,5	450	H (m)	47	40	34	30	26,2	23,5	20,3						
AQUAJET 102 M	1x220-240 V	1,13	0,75	1	5,1	16	450		53,8	47	41	36,3	32,4	28,8	25,8						
AQUAJET 112 M	1x220-240 V	1,4	1	1,36	6,2	25	450		61	54	47,8	42,8	38,8	34,8	22						
ASSO JET 102 T	3x230-400 V	1,04	0,75	1	3,3-1,9	-	-		53,8	47	41	36,3	32,4	28,8	25,8						

MODEL	ELECTRICAL DATA							HYDRAULIC DATA (n _~ 2800 1/min)													
	VOLTAGE 50 Hz	P1 MAX kW	P2 NOMINAL		I _n A	CAPACITOR		Q													
			kW	HP		μF	Vc	m ³ /h	0	0,6	1,2	1,8	2,4	3	3,6	4,2	4,5				
JET 151 -45/50	3x230-400 V	1,6	1,1	1,5	5,2-3	-	-	H (m)	61	58,2	56	53	50	46	43	39,5	36				

MODEL	ELECTRICAL DATA							HYDRAULIC DATA (n _~ 2800 1/min)													
	VOLTAGE 50 Hz	P1 MAX kW	P2 NOMINAL		I _n A	CAPACITOR		Q													
			kW	HP		μF	Vc	m ³ /h	0	0,6	1,2	1,8	2,4	3	3,6	4,2	4,5	6	7,2		
JET 251 -45/100	3x230-400 V	2,2	1,85	2,5	6,9-4	-	-	H (m)	62	60	58	56	54	51	48,5	46	43,5	39	34,2		



PUMPAUTOMAT

