

P163 och P165 Kopplingsmutter och Klämring

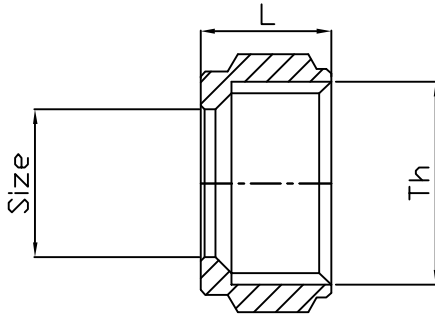

P163 Nut

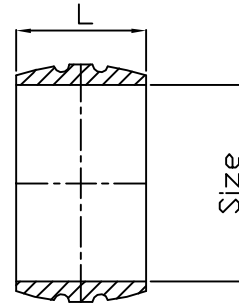

P165 Olive

Product Code	Size	L	Th
P163.02	8	11.9	1/4" B.S.P
P163.03	10	12.7	3/8" B.S.P
P163.04	12	12.7	3/8" B.S.P
P163.05	15	13	1/2" B.S.P
P163.055	16	13	1/2" B.S.P
P163.06	18	14.25	∅23.8 x 14 T.P.I
P163.07	22	13.4	1.1/8" B.S.P x 14 T.P.I
P163.08	28	15	∅38.5 x 14 T.P.I
P163.09	35	18	∅42.42 x 14 T.P.I
P163.10	42	20	∅49.02 x 14 T.P.I
P163.11	54	21	∅62.69 x 14 T.P.I

Product Code	Size	L
P165.02	8	6.35
P165.03	10	6.7
P165.04	12	6.7
P165.05	15	6.7
P165.054	16	6.7
P165.06	18	7.25
P165.07	22	7.2
P165.08	28	8.8
P165.10	35	9.6
P165.11	42	9.6
P165.12	54	10.4



TO BE USED FOR REFERENCE ONLY

First Angle Projection

* Information not available