



**INSTITUTO DE CIENCIAS
DE LA CONSTRUCCIÓN
EDUARDO TORROJA**

C/ Serrano Galvache n. 4 28033 Madrid (Spain)
Tel.: (34) 91 302 04 40 Fax: (34) 91 302 07 00
direccion.ietcc@csic.es www.ietcc.csic.es

European Technical Assessment

**ETA 22/0101
of 03/05/2022**

English translation prepared by IETcc. Original version in Spanish language

General Part

Technical Assessment Body issuing the ETA designated according to Art. 29 of Regulation (EU) 305/2011:

Instituto de Ciencias de la Construcción Eduardo Torroja (IETcc)

Trade name of the construction product

Novipro ceiling anchor KS-X

Product family to which the construction product belongs

Anchor made of galvanized steel for multiple use for non-structural applications in concrete.

Manufacturer

Dahl Sverige AB
Bryggerivägen 9
168 67 Bromma. Sweden.
website: www.dahl.se

Manufacturing plants

Dahl Sverige AB plant 2

This European Technical Assessment contains

8 pages including 3 annexes which form an integral part of this assessment.

This European Technical Assessment is issued in accordance with regulation (EU) No 305/2011, on the basis of

European Assessment Document 330474-00-0601 "Fasteners for use in concrete for redundant non-structural systems", edition May 2018

English translation prepared by IETcc

This European Technical Assessment is issued by the Technical Assessment Body in its official language. Translations of this European Technical Assessment in other languages shall fully correspond to the original issued document and should be identified as such.

This European Technical Assessment may be withdrawn by the issuing Technical Assessment Body, in particular pursuant to information by the Commission according to article 25 (3) of Regulation (EU) No 305/2011.

SPECIFIC PART

1. Technical description of the product

The Novipro ceiling anchor KS-X in diameter 6 is an anchor made of galvanized steel. The anchor is installed into a predrilled cylindrical hole and anchored by deformation-controlled expansion.

Product and product description is given in annex A.

2. Specification of the intended use in accordance with the applicable European Assessment Document.

The performances given in section 3 are only valid if the anchor is used in compliance with the specifications and conditions given in annex B.

The verifications and assessment methods on which this European Technical Assessment is based lead to the assumption of a working life of the anchor of at least 50 years. The indications given on the working life cannot be interpreted as a guarantee given by the producer, but are to be regarded only as a mean to choosing the right products in relation to the expected economically reasonable working life of the works.

3. Performance of the product and references to the methods used for its assessment

3.1 Safety in case of fire (BWR 2)

Essential characteristic	Performance
Reaction to fire	Anchorage satisfy requirements for class A1
Essential characteristics under fire exposure	See annex C2

3.2 Safety in use (BWR 4)

Essential characteristic	Performance
Essential characteristics in concrete	See annex C2

4. Assessment and Verification of Constancy of Performances (hereinafter AVCP) system applied, with reference to its legal base

The applicable European legal act for the system of Assessment and Verification of Constancy of Performances (see annex V to Regulation (EU) No 305/2011) is 97/161/EC.

The system to be applied is 2+.

5. Technical details necessary for the implementation of the AVCP system, as provided for in the applicable European Assessment Document.

The technical details necessary for the implementation of the AVCP system are laid down in the quality plan deposited at Instituto de ciencias de la construcción Eduardo Torroja.

English translation prepared by IETcc



Instituto de ciencias de la construcción Eduardo Torroja
CONSEJO SUPERIOR DE INVESTIGACIONES CIENTÍFICAS

C/ Serrano Galvache n.º 4. 28033 Madrid.
Tel: (+34) 91 302 04 40 Fax. (+34) 91 302 07 00
www.ietcc.csic.es



On behalf of the Instituto de Ciencias de la Construcción Eduardo Torroja
Madrid, 3rd of May 2022



Director IETcc - CSIC

Product and installed condition

KS-X ceiling anchor

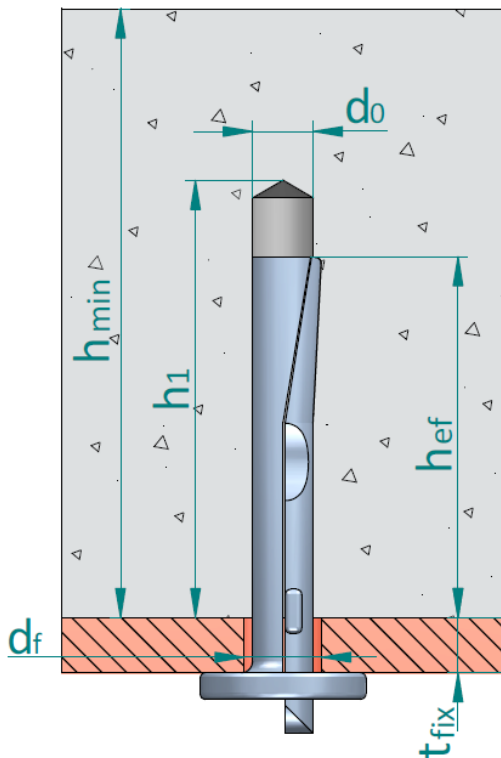
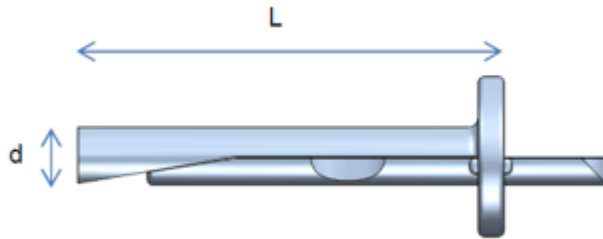

Anchor dimensions	6x40	6x70
d: diameter [mm]	6	6
L: length [mm]	40	70

- d₀: Nominal diameter of drill
- d_f: Fixture clearance hole diameter
- h_{ef}: Effective anchorage depth
- h₁: Depth of drilled hole
- h_{min}: Minimum thickness of concrete member
- t_{fix}: Fixture thickness

Table A1: materials

Item	Designation	Material for KS-X
1	Anchor body	Carbon steel wire rod, galvanized ≥ 5 μm ISO 4042 A2
2	Shank	Carbon steel wire rod, galvanized ≥ 5 μm ISO 4042 A2

KS-X ceiling anchor

Product description

Installed condition and materials

Annex A1

Specifications of intended use

Anchorage subjected to:

- Static or quasi static loads for redundant non-structural systems.
- Use for anchorages with requirements related to resistance of fire.
- The anchor may only be used if in the design and installation specifications for the fixture the excessive slip or failure of one anchor will not result in a significant violation of the requirements on the fixture in the serviceability and ultimate state.

Base materials:

- Reinforced or unreinforced normal weight concrete without fibres according to EN 206-1:2013+A1:2016.
- Strength classes C20/25 to C50/60 according to EN 206-1:2013+A1:2016.
- Cracked or uncracked concrete

Use conditions (environmental conditions):

- Anchorages subjected to dry internal conditions.

Design:

- Anchorages are designed under the responsibility of an engineer experienced in anchorages and concrete.
- Verifiable calculation rules and drawings are prepared taking into account of the loads to be anchored. The position of the anchor is indicated on the design drawings (e.g. position of the anchor relative to reinforcement or to supports, etc.).
- Anchorages under static or quasi-static actions are designed for design method C in accordance with EN 1992-4:2018
- Anchorages under fire exposure are designed in accordance to EN 1992-4:2018. It must be ensured that local spalling of the concrete cover does not occur.

Installation:

- Hole drilling by rotary plus hammer mode.
- Anchor installation carried out by appropriately qualified personal and under the supervision of the person responsible for technical matters of the site.
- Anchor expansion by impact on the shank. The anchor is properly set, if no further driving by impact is possible and the excess of the shank is at maximum 2,5 mm.
- The anchor may only be set once.

KS-X ceiling anchor	Annex B1
Intended use	
Specifications	

Table C1: Installation parameters for KS-X ceiling anchor

Installation parameters			Performances	
			KS-X 6 x 40	KS-X 6 x 70
d_0	Nominal diameter of drill bit:	[mm]	6	
d_f	Fixture clearance hole diameter:	[mm]	7	
h_{min}	Minimum thickness of concrete member:	[mm]	80	
h_1	Depth of drilled hole \geq	[mm]	40	
h_{ef}	Effective anchorage depth \geq	[mm]	32	
t_{fix}	Thickness of fixture:	[mm]	0 - 5	0 - 35
s_{min}	Minimum spacing:	[mm]	200	
c_{min}	Minimum edge distance:	[mm]	150	

Installation process

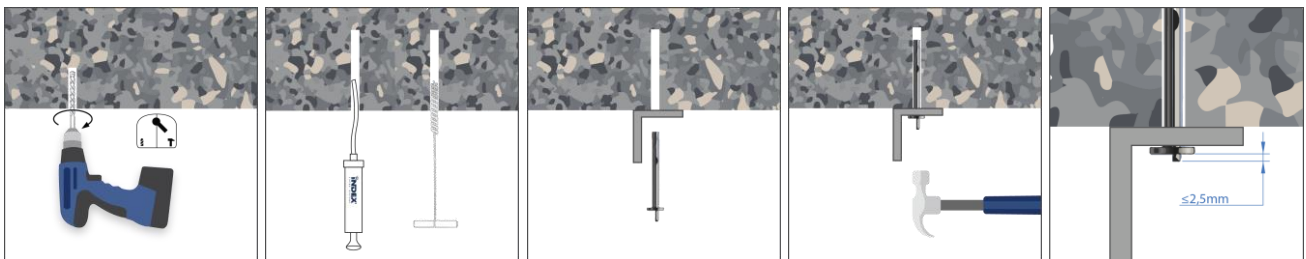

KS-X ceiling anchor

Performances

Installation parameters and installation procedure

Annex C1

Table C2: Essential characteristics in concrete to loads of design method C according to EN 1992-4 for KS-X ceiling anchor

Characteristic values of resistance to loads of design method C			Performances	
			KS-X 6 x 40	KS-X 6 x 70
Any load direction				
F_{Rk}^0	Characteristic resistance in C20/25 to C50/60 concrete:	[kN]	3,0	
γ_{inst}	Installation safety factor: ¹⁾	[-]	1,2	
Shear loads: steel failure with lever arm				
$M_{Rk,s}^0$	Characteristic bending moment	[Nm]	3,68	
γ_{Ms}	Partial safety factor: ¹⁾	[-]	1,25	

¹⁾ in absence of other national regulations

Table C3: Essential characteristics under fire exposure in concrete in any load direction according to EN 1992-4 for KS-X ceiling anchor

Characteristic resistance under fire exposure in concrete C20/25 to C50/60 in any load direction			Performances	
			KS-X 6 x 40	KS-X 6 x 70
R30	Characteristic resistance $F_{Rk,fi,30}^0$ ¹⁾	[kN]	0,41	
R60	Characteristic resistance $F_{Rk,fi,60}^0$ ¹⁾	[kN]	0,30	
R90	Characteristic resistance $F_{Rk,fi,90}^0$ ¹⁾	[kN]	0,19	
R120	Characteristic resistance $F_{Rk,fi,120}^0$ ¹⁾	[kN]	0,14	
R30 to R120	Minimum spacing $s_{min,fi}$	[mm]	200	
	Minimum edge distance $c_{min,fi}$ ²⁾	[mm]	150	

¹⁾ in absence of other national regulations the partial safety factor for resistance under fire exposure $\gamma_{M,fi}$ =1.0 is recommended.

²⁾ If fire attack is from more than one side, the design method may be taken if edge distance of the anchor is $c \geq 300$

KS-X ceiling anchor

Performances

Essential characteristics in concrete
Essential characteristics under fire exposure

Annex C2